



CCD Camera
CleverDragon series
CSCV90BC3
Specification
Ver. 1.3

CONTENTS

Restriction For Use	2
Exemption Clauses	3
Notes on using this product	4
1. Overview	7
2. Features	7
3. Configuration	8
4. Option parts	8
5. Function	8
6. Specification	13
7. Timing Chart	17
8. Guarantee	22
9. Repair	22
10. External-view Drawing	23

TOSHIBA TELI CORPORATION

Restriction For Use

- Should the equipment be used in the following conditions or environments, give consideration to safety measures and inform us of such usage:
 1. Use of the equipment in the conditions or environment contrary to those specified, or use outdoors.
 2. Use of the equipment in applications expected to cause potential hazard to people or property, which require special safety measures to be adopted.
- This product can be used under diverse operating conditions. Determination of applicability of equipment or devices concerned shall be determined after analysis or testing as necessary by the designer of such equipment or devices, or personal related to the specifications. Such designer or personal shall assure the performance and safety of the equipment or devices.
- This product is not designed or manufactured to be used for control of equipment directly concerned with human life (*1) or equipment relating to maintenance of public services/functions involving factors of safety (*2). Therefore, the product shall not be used for such applications.

(*1): Equipment directly concerned with human life refer to:

Medical equipment such as life-support systems, equipment for operating theaters.

Exhaust control equipment for exhaust gases such as toxic fumes or smoke.

Equipment mandatory to be installed by various laws and regulations such as the Fire Act or Building Standard Law.

Equipment related to the above.

(*2): Equipment relating to maintenance of public service/functions involving factors of safety refer to:

Traffic control systems for air transportation, railways, roads, or marine transportation.

Equipment for nuclear power generation.

Equipment related to the above.

Although sufficient check is performed about translation of these specifications, we will apply a Japanese sentence, if a doubt should occur.

Exemption Clauses

- TELI assumes no responsibility or liability for damage arising from fire, earthquake, an act by a third party or other accidents, or intentional or careless error or misuse by the user, or use under abnormal conditions.
- TELI assumes no responsibility or liability for incidental damages (e.g., loss of business profits or interruption of business) arising from use of or inability to use the camera equipment.
- TELI assumes no responsibility or liability in the case damages or losses are caused by failure to observe the information contained in the operation manual and specifications.
- TELI assumes no responsibility or liability in the case damages or losses are caused by use contrary to the instructions in this operation manual and specifications.
- TELI assumes no responsibility or liability in the case damages or losses are caused by malfunction or other problems resulting from use of equipment or software that is not specified.
- TELI assumes no responsibility or liability in the case damages or losses are caused by repair or modification conducted by the customer or any unauthorized third party (such as an unauthorized service representative).
- Expenses we bear on this product shall be limited to the individual price of the product.
- TELI does NOT guarantee the items that are not described in the specification.

- **Handle carefully**

Do not drop the equipment or allow it to be subject to strong impact or vibration, as such action may cause malfunctions. Further, do not damage the connection cable, since this may cause wire breakage.

- **Environmental operating conditions**

Do not use the product in locations where the ambient temperature or humidity exceeds the specifications. Otherwise, image quality may be degraded or internal components may be adversely affected. In particular, do not use the product in areas exposed to direct sunlight. Moreover, during shooting under high temperatures, vertical stripes or white spots (noise) may be produced, depending on the subject or camera conditions (such as increased gain). However, such phenomena are not malfunctions.

- **Regarding a lens mount**

Install a next lens; the C mount lens, its dimension of protrusion from flange is equal to or less than 7.9 mm. If a lens does not stand to this condition, it might not be installed to this camera.

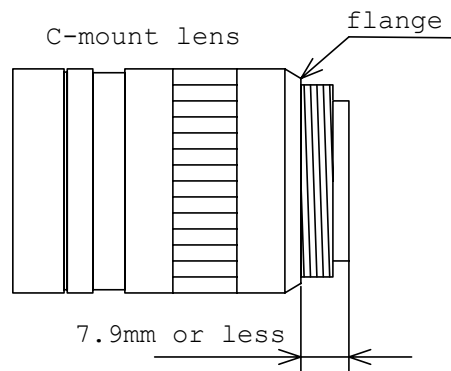

- **Check a combination with the lens**

Depending on the lens and lighting you use, an image is reflected as a ghost in the imaging area. However, this is not because of a fault of the camera.

In addition, depending on the lens you use, the performance of the camera may not be brought out fully due to deterioration in resolution and brightness in the peripheral area, aberration and others.

Be sure to check a combination with the camera by using the lens and lightning you actually use.

When installing a lens in the camera, make sure carefully that it is not tilted.

In addition, use a mounting screw free from defects and dirt. Otherwise, the camera may be unable to be removed.

- **Avoid intensive light**

Do NOT expose the camera's image-pickup-plane to sunlight or other intense light directly. If the part of CCD is exposed to spot-intensive light, you might get a picture problem like blooming and/or smear. Under the comparison at the same video output level, the shorter the exposure time setting, the more smear is generated.

- **Occurrence of moiré**

If you shoot thin stripe patterns, moiré patterns (interference fringes) may appear. This is not a malfunction.

- **Occurrence of noise on the screen**

If an intense magnetic or electromagnetic field is generated near the camera or connection cable, noise may be generated on the screen. If this occurs, move the camera or the cable.

- **Handling of the protective cap**

If the camera is not in use, attach the lens cap to the camera to protect the image pickup surface.

- **If the equipment is not to be used for a long duration**

Turn off power to the camera for safety.

- **Maintenance**

Turn off power to the equipment and wipe it with a dry cloth.

If it becomes severely contaminated, gently wipe the affected areas with a soft cloth dampened with diluted neutral detergent. Never use alcohol, benzene, thinner, or other chemicals because such chemicals may damage or discolor the paint and indications.

If the image pickup surface becomes dusty, contaminated, or scratched, consult your sales representative.

CAUTIONS ON USE

- When disposing of the camera

Wastes of this product should be separated and discarded in compliance with the various national and local ordinances.

This camera is showing the following symbol to body due to EU environmental regulation (Waste Electrical and Electronic Equipment (WEEE)). However this symbol is applied to only a EU member state.

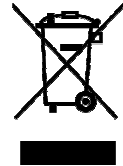

1. Overview

CleverDragon series CSCV90BC3 is an integrated type B/W CCD camera with a VGA format all-pixel-data readout CCD. This model has thrice greater driving frequency of conventional cameras to achieve fast-speed data-processing. The model is suited for high-speed, high-resolution image processing use. Its compact, light-weight body is ideal for system integration.

2. Features

(1) Triple-speed reading

CSCV90BC3 reads image data 3 times faster than the conventional CCD camera.

(2) All-pixel reading

The all-pixel reading system allows the CSCV90BC3 to read all pixels in just 1/90 second. CSCV90BC3 is equipped with a full-frame shutter that allows all-pixel reading even during shutter operations.

(3) Full-frame shutter

Since all pixels are output even by a random trigger shutter operation, high resolution can be achieved, without deteriorating the vertical resolution.

(4) Tetragonal lattice layout

The tetragonal lattice layout of CCD pixels facilitates computation for image processing.

(5) Camera Link interface (power supply type)

By using a Camera Link-capable frame grabber board to which power can be supplied, high-speed transfer of captured images to a PC as well as various types of camera control from the PC are allowed. Power can also be supplied to the camera with only one cable.

(6) Random trigger shutter function

CSCV90BC3 is equipped with a random trigger shutter, which starts exposure synchronized with external trigger signals. Fast-moving objects can thus be captured in place, which ensures accurate image processing.

(7) Restart-Reset

Images can be shot and fetched at arbitrary timing based on external VD signal input.

(8) Partial scan

Speed is further increased because areas other than the image output range specified by the user are not read.

(9) Ultra-compact and lightweight main unit

The space-saving ultra-compact and lightweight camera has excellent resistance against vibration and impact.

(10) Conformity to RoHS directive

The CleverDragon series is manufactured in compliance with the European RoHS directive, which prohibits the use of hazardous substances.

3. Configuration

Camera body	1
Operation Manual (Japanese)	1
Operation Manual (English)	1

4. Option parts

- (1) Camera mounting kit CPT8560

*NOTE: Contact your dealer / distributor for details of option units.

*NOTE: Application software is not supplied as a standard item.

5. Function

5-1. Serial communication control

By CameraLink serial communication interface, it is possible to control the following functions.

- | | |
|----------------------------|--|
| (1) Set-up Addition Value | 10bit: +0 to +255 [digit]
8bit: +0 to +63 [digit] |
| (2) Gain | 0dB to Approx. +12dB |
| (3) Shutter Speed | 8[sec] to 1/20,000[sec] |
| (4) Random Trigger Shutter | ON / OFF
* Restart-Reset mode must be disabled. |
| • Trigger / VD Polarity | Positive / Negative |
| • Random Trigger Mode | Fix / Pulse Width |
| (5) Restart-Reset | ON / OFF
* Random Trigger Shutter mode must be disabled. |
| (6) Partial Scan | Video output start line, Video output width
Minimum width: 120H |

Power supply from PoCL cable

- | | |
|-----------|--|
| Pin 1, 26 | +12V±10% (ripple level: 50mV _{p-p} or less) |
|-----------|--|

5-2. Command Communication Protocol

The command communication protocol is the telnet standard method (method in which parameters are set in the registers in the camera).

In command send/receive operation, hexadecimal address and data are converted to ASCII data.

All ASCII alphabetic characters used are uppercase characters.

(1) Write to a register

To write data in a register, send a command, as follows. (Address' max-length is 2 bytes, and Data's max-length is 8 bytes)

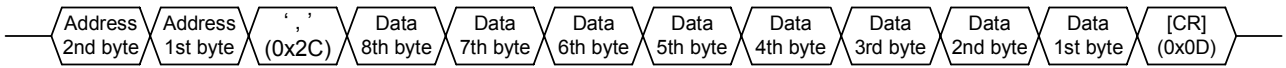

For example, to write data 0x38 to address 0x76, send a command, as follows:

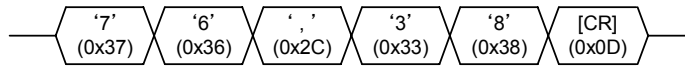

The camera responds to the write command with No Error (ACK) or Error (NAK), as follows:

No Error (ACK):

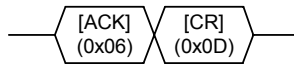

Error (NAK):

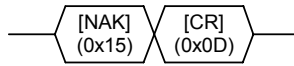

(2) Reading the register

To read data from a register, send ' , (comma)', 'R', 'Q' and [CR] code following the address. For example, to read data in address 0x91, send a command, as follows:

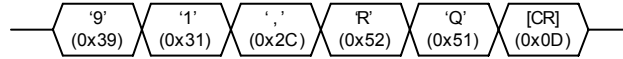

The camera responds to the read request, as follows (Data's max-length is 8 bytes):

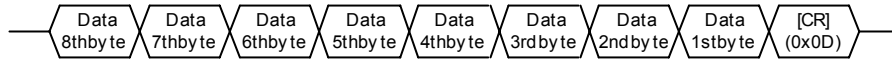

Actually, the camera responds to the read request as minimum data length: For example, to read data 0x10 to address 0x91, the camera responds as follows:

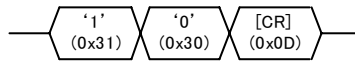

5-3. Register Map

Address	Read Write	B&W Camera CSCV90BC3	
0x00	R.O.	Maker Name ASCII Format	Maker Name TOSHIBA TELI
0x0F			
0x10	R.O.	Model Name ASCII Format	Model Name CSCV90BC3
0x2F			
0x30	R.O.	Serial Number ASCII Format	Serial Number ex) 0100011
0x3F			
0x40	R.O.	Firmware Version ASCII Format	Firmware Version ex) 01.01.01
0x47			
0x48	R.O.	FPGA Version ASCII Format	FPGA Version ex) 01.01.02
0x4F			
0x50	R.O.	CPLD1 Version ASCII Format	CPLD1 Version ex) 01.01.01
0x57			
0x58	N.A.	Reserved	
0x5F	N.A.	Reserved	Register Map Version ex) 01.01
0x60	R.O.	Register Map Version ASCII Format	Status Status information after Camera Controlling
0x67			
0x68	N.A.	Reserved	Expanded Status Detail information of the status
0x69	R.O.	Status	
0x6A	R.O.	Expanded Status	Memory Bank Confirmation The information of memory banks the setting saved. 0x01(Saved), 0x00(Not saved)
0x6B	N.A.	Reserved	
0x6C	R.O.	Memory Bank Confirmation	
0x6D	W.O.	Save to Memory	Saved to Memory Write 0x01 : Save the current camera settings. The camera uses saved settings after rebooting.
0x6E	R/W	Load from Memory	
0x6F	W.O.	Initialize Memory	
0x70	R/W	Setup (Offset) Addition Value	Read from Memory Write 0x01 : Load saved settings.
0x71	N.A.	Reserved	
0x75	N.A.	Reserved	
0x76	R/W	Gain	Initialize Memory Write 0x01 : Delete saved user settings.
0x77	N.A.	Reserved	
0x7F	N.A.	Reserved	Setup (Offset) Addition Value 0-255 Default : 0

R/W	Read/Write
R.O.	Read Only
W.O.	Write Only
N.A.	Not Available

Gain	0(0dB)-90(Approx.+12dB) Default : 0(0dB)
-------------	---

Address	Read Write	B&W Camera CSCV90BC3
0x80	R.O.	Frame Rate
0x82	R.O.	Horizontal Resolution
0x84	R.O.	Vertical Resolution
0x86	N.A.	Reserved
0x87	R/W	Output Bit
0x88	N.A.	Reserved
0x8F	N.A.	Reserved
0x90	R/W	Scan Mode
0x91	R/W	Shutter Mode
0x92	R/W	Random Trigger Shutter Mode
0x93	R/W	Trigger Polarity
0x94	N.A.	Reserved
0x9F	N.A.	Reserved
0xA0	R/W	Shutter Speed (denominator)
0xA2	N.A.	Reserved
0xA3	N.A.	Reserved
0xA4	R/W	Shutter Speed (numerator)
0xA5	N.A.	Reserved
0xBF	N.A.	Reserved
0xC0	W.O.	Partial Scan Update
0xC1	N.A.	Reserved
0xC3	N.A.	Reserved
0xC4	R/W	Video Start Line @ Partial Scan
0xC6	N.A.	Reserved
0xC7	N.A.	Reserved
0xC8	R/W	Video Width @ Partial Scan
0xCA	N.A.	Reserved
0xFF	N.A.	Reserved

R/W Read/Write
R.O. Read Only
W.O. Write Only
N.A. Not Available

Frame Rate (@Normal Shutter)
Normal : 90fps
Partial : The calculation from partial video width.
(Omit it after the decimal point.)
Default : 90fps @ Normal Scan

Horizontal Resolution
648 (fixed)

Vertical Resolution
494 @ Normal Scan
Video Width @ Partial Scan
Default : 494 @ Normal Scan

Output Bit
8(8bit),10(10bit)
Default : 8(8bit)

Scan Mode
0(Normal),1(Partial)
Default : 0(Normal)

Shutter Mode
0(Normal Shutter),1(Random Trigger),2(Restart Reset)
Default : 0(Normal Shutter)

Random Trigger Shutter Mode
0(Fix),1(Pulse Width)
Default : 0(Fix)

Trigger Polarity
0(Nega),1(Posi)
Default : 0(Nega)

Shutter Speed (denominator)
1-20000
Default : 90

Shutter Speed (numerator)
1-255
Default : 1

Partial Scan Update
Write 0x01 : Update registers related with Partial Scan

Video Start Line @ Partial Scan
0-374
Default : 0

Video Width @ Partial Scan
120-494
Default : 494

6. Specification

[Electrical specification]

(1) Imager	all-pixel-data-readout interline transfer CCD
Number of total pixels	692(H) × 504(V)
Number of effective pixels	659(H) × 494(V)
Number of Video out pixels	648(H) × 494(V)
Scanning area	4.88mm(H) × 3.66mm(V) (= Equivalent to 1/3" type CCD size)
Pixel size	7.4μm(H) × 7.4μm(V)
(2) Scan method	Non- interlace
(3) Synchronization method	Internal synchronization
(4) Aspect ratio	4:3
(5) Video Output	Compliant with CameraLink standard version 1.2
Data	10 / 8 bit switching (factory default: 8bit)
Readout mode	
All pixel readout (factory default)	648(H) × 494(V) [Approx. 92.4fps]
Partial Scan (representing value)	648(H) × 120(V) [Approx. 293.9fps] 648(H) × 240(V) [Approx. 173.1fps] 648(H) × 480(V) [Approx. 94.8fps] minimum lines: 120, minimum step: 1 line
(6) Sensitivity	600 lx, F5.6
(7) Minimum subject illuminance	6lx F1.4 (GAIN: 10dB, video level: 50 %)
(8) Gain	0 to Approx. +12 dB [1step= Approx. 0.132dB]
(9) Setup Level (factory default)	40 ±20 [digit] (10bit)
	10 ± 5 [digit] (8bit)
(addition value)	+0 to +255 [digit] (10bit, 255 steps) +0 to +63 [digit] (8bit, 255 steps)
(10) Gamma correction	OFF (γ = 1.0 fixed)
(11) Power supply voltage	DC12V ± 10% (ripple 50mV _{p-p} or less)
(12) Power consumption	Approx. 1.6W

[Electrical shutter specification]

- | | |
|--|---|
| (1) Shutter Speed | 8/1 to 1/20,000 [sec]
Setting format: Numerator / Denominator [sec]
Numerator: 1 to 255
Denominator: 1 to 20,000 |
| (2) Random Trigger Shutter | ON / OFF switching (factory default: OFF)
The exposure time depends on the shutter speed setting |
| <ul style="list-style-type: none"> • Fixed mode • pulse width mode | The exposure time depends on the pulse width. |
| (3) Restart-Reset | ON / OFF switching (factory default: OFF)
The exposure time depends on the period of Ext. VD. |

[Internal sync signal specification]

- | | |
|-------------------------------|---|
| (1) Driving frequency | 36.000 MHz (1 CLK) ± 100 ppm |
| (2) Horizontal sync frequency | 46.153 kHz (1H = 780CLK) |
| (3) Vertical sync frequency | 92.4 Hz (maximum frequency on all pixel readout mode) |

[Input signal specification]

- | | |
|---|---|
| (1) TRIG/VD | Camera Link interface input: CC1 |
| <ul style="list-style-type: none"> • Polarity • Pulse width | Positive/Negative switching (factory default: Negative)
Minimum: 2 μ s |

[Camera PSU input impedance]

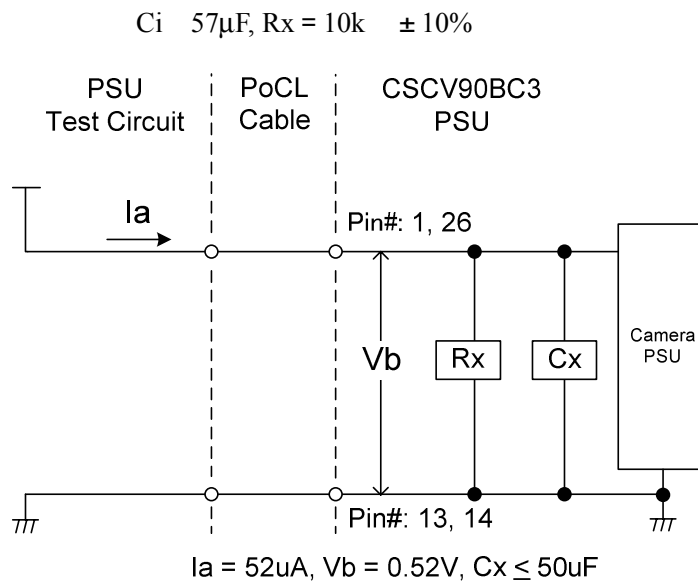

[Mechanical spec]

- | | |
|--|---|
| (1) Lens mount | C-mount
*Depending on the lens you use, the performance of the camera may not be brought out fully due to the deterioration in resolution and brightness in the peripheral area, occurrence of the ghost, aberration and others. When you check the combination between the lens and camera, be sure to use the lens you actually use. |
| (2) Dimensions | 29mm(W) × 29mm(H) × 26.5mm(D)
* Not including protrusion |
| (3) Mass | Approx. 45g |
| (4) Camera body grounding: insulation status | Conductive between circuit GND and camera body |

[Operating ambient conditions]

- | | |
|---|--|
| (1) Performance assurance | Temperature: 0°C to +40°C
Humidity: 10% to 90% (no condensation) |
| (2) Operation guaranteed | Temperature: -5°C to +45°C
Humidity: 90% or less (no condensation) |
| (3) Storage | Temperature: -20°C to +60°C
Humidity: 95% or less (no condensation) |
| (4) EMC conditions (Electro-Magnetic Compatibility) | |
| EMI (Electro-Magnetic Interference) | |
| EN61000-6-4 | |
| EMS (Electro-Magnetic Susceptibility) | |
| EN61000-6-2 | |
| (5) FCC | FCC Part 15 Subpart B class A |

* About the conformity of EMC standard of this machine, it has guaranteed in the conditions combined with our system condition. When used combined parts other than specification of our company, I ask you to have final EMC conformity checked of a visitor with a machine and the whole equipment.

[Communication specification]

- | | |
|-------------------------|------------------|
| (1) Communication speed | 9600 bps (fixed) |
| (2) Start bit | 1 |
| (3) Data bit | 8 |
| (4) Parity | None |
| (5) Stop bit | 1 |
| (6) Handshake | None |

[Connector pin assignment]

Video output/controlling/power supply connector: (Camera Link Base Configuration) CAMERA LINK

Connector model: HDR-EC26FDTG2+ (Manufactured by Honda Connectors)

Pin #	I/O	Signal name	Pin #	I/O	Signal name
1	-	+12V	14	-	GND
2	O	TxOUT0-	15	O	TxOUT0+
3	O	TxOUT1-	16	O	TxOUT1+
4	O	TxOUT2-	17	O	TxOUT2+
5	O	TxCLK OUT-	18	O	TxCLK OUT+
6	O	TxOUT3-	19	O	TxOUT3+
7	I	SerTC (RxD) +	20	I	SerTC (RxD) -
8	O	SerTFG (TxD) -	21	O	SerTFG (TxD) +
9	I	CC1 (TRIG/VD) -	22	I	CC1 (TRIG/VD) +
10	I	CC2+	23	I	CC2-
11	I	CC3-	24	I	CC3+
12	I	CC4+	25	I	CC4-
13	-	GND	26	-	+12V

[Typical ambient conditions]

*The lens characteristics and light source characteristics are not reflected in table.

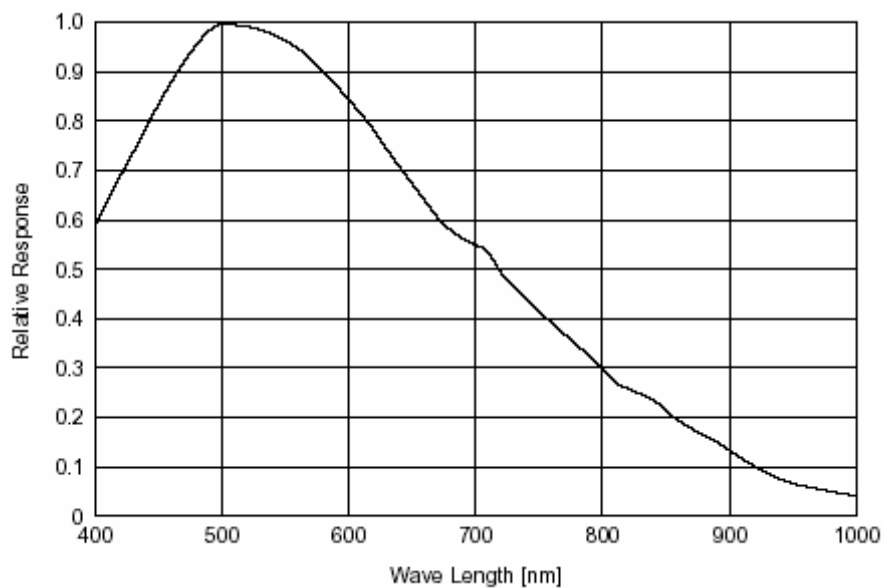

7. Timing Chart

7-1. Normal Scan (All pixel readout)

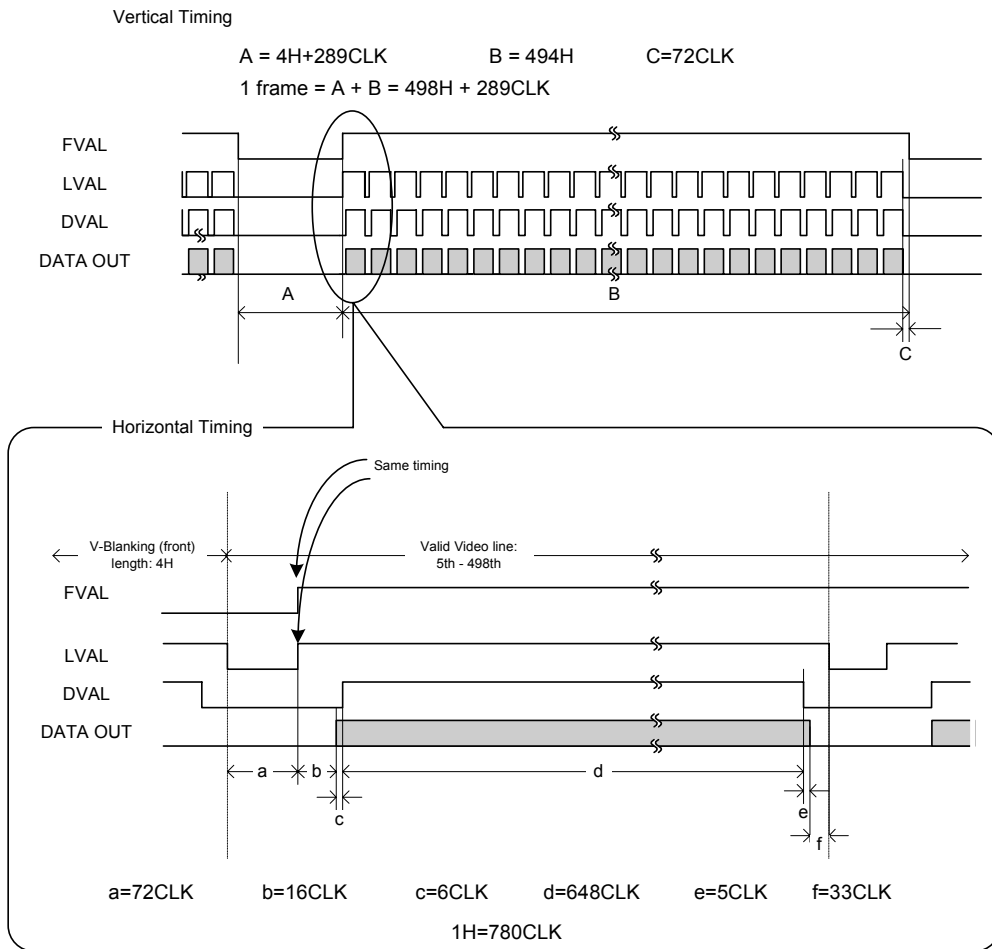

7-2. Partial Scan

ex.1) Video Start Line =120, Video Width = 240

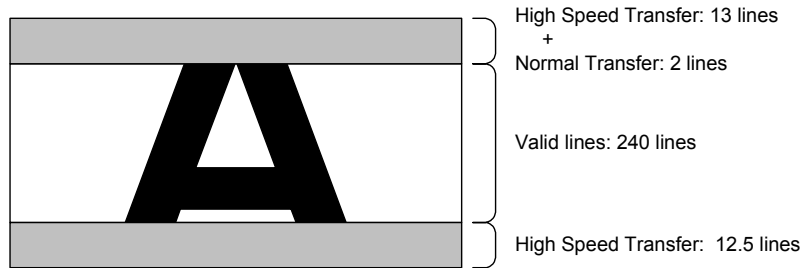
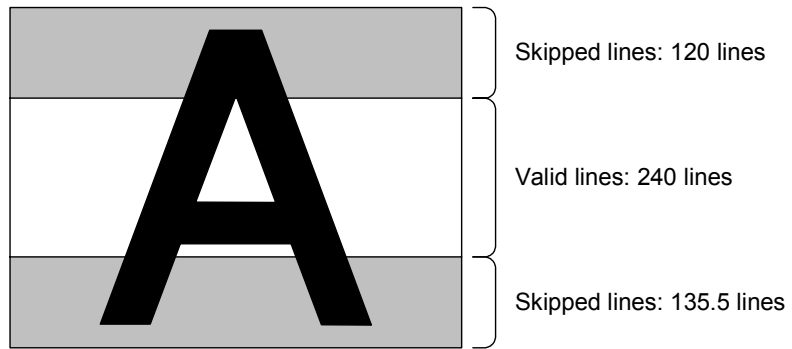
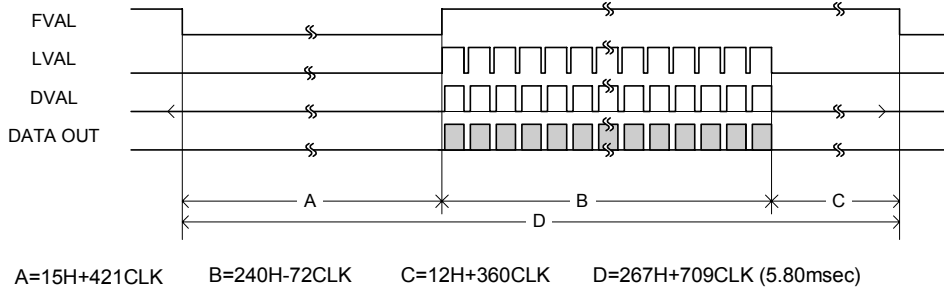

ex. 2) Video Start Line =180, Video Width=120

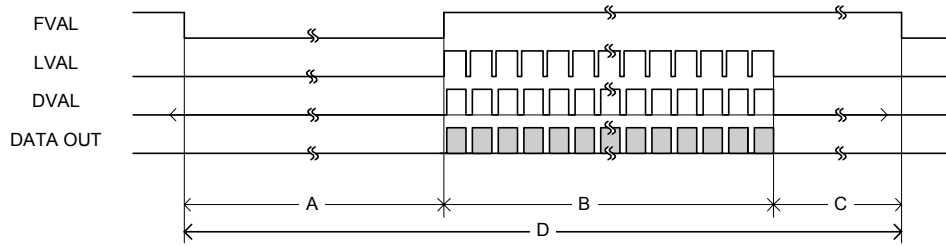

$A = 21H + 61CLK$ $B = 120H - 72CLK$ $C = 18H$ $D = 158H + 769CLK (3.44msec)$

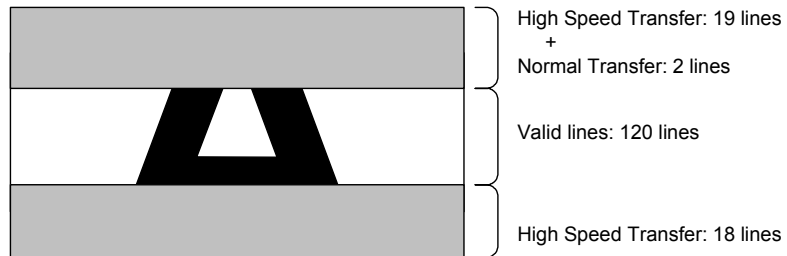
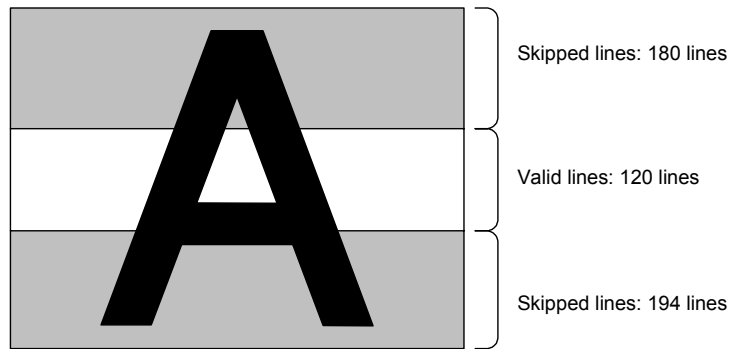

7-3. Random Trigger Shutter

In the random trigger shutter mode, you can shoot and grab an image at an arbitrary timing by trigger signal input from the external (It is not possible to use the Random Trigger Shutter concurrently with the Restart Reset mode).

- External trigger signals can be input either from the camera link I/F CC1.
- If polarity is set to negative polarity, exposure starts at the falling edge of the trigger.
- The random trigger shutter of this camera can be operated in two types of mode: fixed mode and pulse width mode. How to determine the exposure time differs depending on the mode.

● Fix mode

The exposure time is determined by the setting value for the shutter speed.

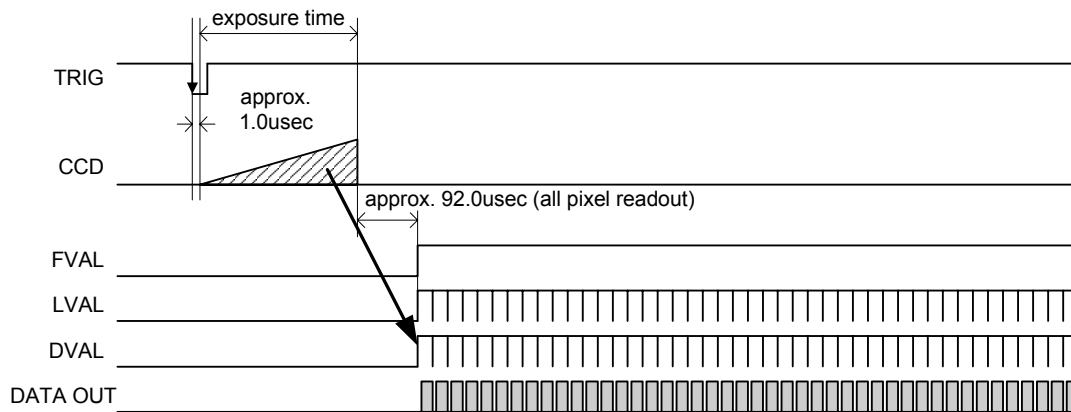

- Pulse Width mode (Trigger Polution:Low Active)

The exposure time is determined by the pulse width

Set a pulse width of 1H (approximately 21.6 μs) or more.

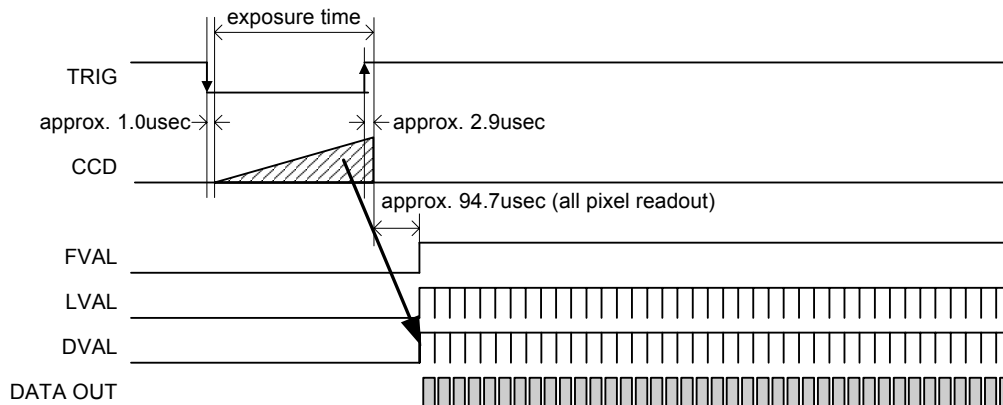

7-4. Restart / Reset

The restart / reset function is available with the ext.VD signal. You can get an arbitrary slower shutter speed than normal shutter and random trigger shutter (It is not possible to use the Restart Reset mode concurrently with the Random Trigger Shutter mode).

- External VD signals can be input either from the camera link I/F CC1.
- The shutter speed (exposure time) is determined by ext. VD signal interval.

1) Vertical Timing

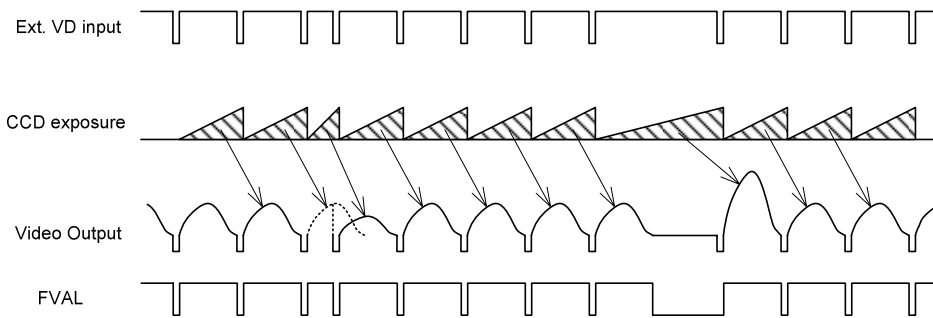

2) Horizontal Timing

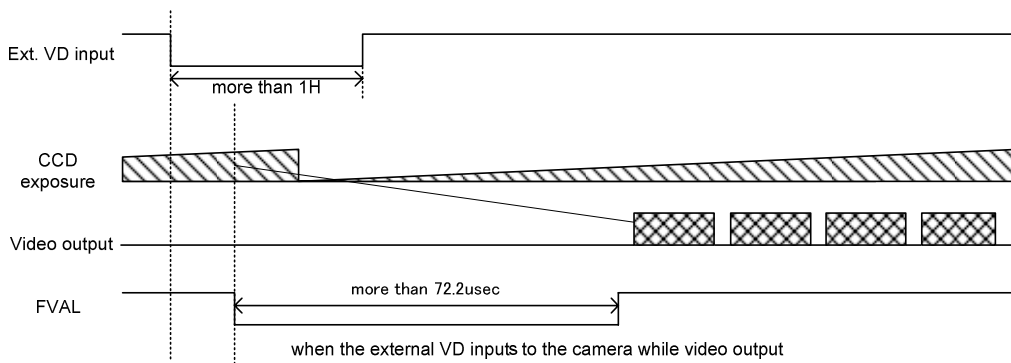

8. Guarantee

The term of a guarantee is one year after the product delivery.

If by any chance trouble by responsibility of our company occurs before an above period, TELI repairs it free of charge.

- During terms of a guarantee, when the trouble cause is the case of below, TELI charges the repair costs.

- (1) Troubles and the damages that causes by misuse, unsuitable repair or remodeling.
- (2) Distribution hazards like drops and vibrations after purchase. Troubles and damages by transportation.
- (3) Troubles and damages by fire, natural calamity (earthquake, storm and flood damage, thunderbolt), damages from salty breeze, gas harm, abnormal voltage.

9. Repair

9-1. Condition for repair

Basically, has to return it to our company when the user requests us to repair product.

Beside that, customer should pay these expenses (travel expenses, camera disassembly technology costs) of both customer and end user. Also customer should pay in themselves costs for return camera to us.

9-2. The period of repairing product

- (1) Repair free of charge ... Refer to Clause 8.
- (2) Charged repair Basically, repair period is 7 years after the last production end of products.

10. External-view Drawing

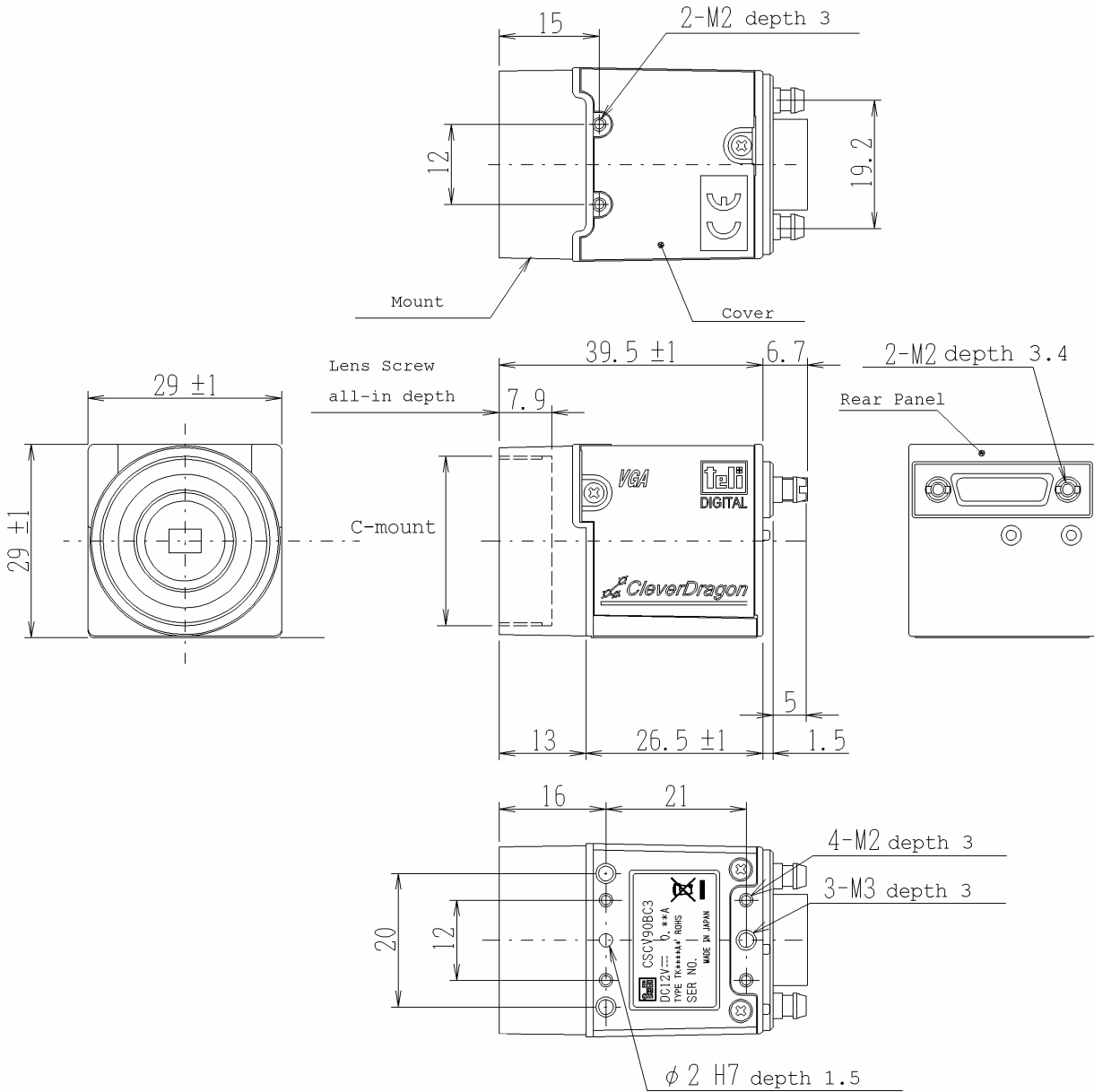

Specification

Material	Lens-mount, Rear panel	: Aluminum die-cast
	Cover	: Anticorrosion aluminum alloy
Processing	Lens-mount, Rear panel	: Cation coating (Black)
	Cover	: Leather satin coating (Black)



TOSHIBA TELI CORPORATION

Head Office: 7-1, 4 chome, Asahigaoka, Hino-shi, Tokyo 191-0065, Japan
[Overseas Sales Section] Phone: +81-042-589-8771, Fax: +81-042-589-8774

Distributor