



B/W CCD Camera

Model CS3821D

Specifications

Contents

1. Product Description	2
2. Features	2
3. Configuration.....	3
4. Optional Accessories	3
5. Function.....	3
5.1 GAIN selection.....	3
5.2 Video output mode selection.....	3
5.3 Shutter mode selection	4
5.4 Partial-scan mode selection.....	9
6. Specifications	16
7. Supplemental Drawings	24
7.1 Relative spectrum Response.....	24
7.2 Optical black layout (Top-view)	24
7.3 Output waveform timing chart (H).....	25
7.4 Output waveform timing chart (V).....	26
7.5 Camera head external-view	28
7.6 Camera cable external-view	29
7.7 CCU external-view.....	30

1. Product Description

Model CS3821D is a two-body type B/W CCD camera with a VGA format all-pixel-data readout CCD. This model has twice-greater driving frequency of conventional cameras to achieve fast-speed data processing. The model is suited for high-speed, high-resolution image processing use. Its compact, lightweight body is ideal for system integration.

2. Features

(1) Double-speed scan

Model CS3821D reads out image-data twice as fast as conventional CCD cameras do.

(2) All pixel's data readout

With all-pixel-data-readout CCD built in, CS3821D reads out image-data in approximately 1/60 sec.

(3) High vertical resolution

As all pixel's data are read out even under RTS (Random Trigger Shutter) mode (in 1/60 sec.), images with no deterioration in vertical resolution are obtained.

(4) Square grid pattern CCD

Pixel's in CCD are aligned in a square grid pattern. This makes it easier to perform computation correctly for image processing use.

(5) External Sync.

The camera is switched over to external synchronization operation automatically when external HD signal are input.

(6) Random trigger shutter function

With a built-in RTS (Random Trigger Shutter), the camera's CCD starts light-exposure in synchronization with external trigger signals. This function enables the camera to capture image at an arbitrary timing.

(7) Restart / Reset

Under the restart / reset mode, this model can capture images at an arbitrary timing cued by external VD signal.

(8) Partial-scan OPTION

Under the partial scan mode, only 1/2 screen center portion of image information is read out. As read-out portion is controlled randomly by external pulse, a faster operation is actualized.

- The function/features noted as "option" or shown with the OPTION mark in this document is available as optional function/feature (= Production on order) and not provided as standard function. Please contact our sales staff for details.
- Under standard version, partial-scan function is not available. (Normal-scan mode only)

3. Configuration

- (1) Camera head..... 1
- (2) Camera Control Unit 1
- (3) Camera cable (2m) 1
- \square OPTION (3m.5m)
- (4) Accessory
 Operation Manual (English / Japanese) 1

4. Optional Accessories

- (1) DC IN/SYNC cable
- (2) Camera adapter
- (3) Camera head mounting kit
- (4) Lens
 - Please contact our sales staff for details.

* Conformity of an option part and EMC conditions

About the conformity of the EMC standard of this machine, it has guaranteed in the conditions combined with the above-mentioned option part.

When used combining parts other than specification of our company, I ask you to have final EMC conformity checked of a visitor with a machine and the whole equipment.

5. Function

5.1 GAIN selection (CCU rear-panel DIP SW)

--- Switches sensitivity setting

- (a) FIX: Factory-shipped gain
- (b) MANU: Gain is adjustable via the manual gain potentiometer (GAIN) on CCU rear-panel

5.2 Video output mode selection (CCU rear-panel DIP-SW) \square OPTION

--- Switches video format

- (a) 1/60N: 1/60s Non-interlace mode
 - As all pixel's data read out in 1/60s, images with high vertical resolution are obtained in this mode.
- (b) 1/120I: 1/120s 2:1 Interlace MIX mode
 - As vertical pixels added in read-out process, the sensitivity is same as that of 1/60s non-interlace mode.

- The function/features noted as "option" or shown with the \square OPTION mark in this document is available as optional function/feature (= Production on order) and not provided as standard function. Please contact our sales staff for details.
- Under standard version, video-output function is not available. (1/60s non-interlace mode only)

5.3 Shutter mode selection (CCU rear-panel DIP SW or TRIG signal IN [Automatic])

--- Switches shutter modes / There are 3 shutter modes.

(5-3-1) NOR mode Normal electronic shutter
Exposure control via internal sync signal
8 positions, including OFF, 1/200s, 1/500s, 1/1000s, 1/2000s,
1/4000s, 1/8000s, 1/20000s

(5-3-2) RDM mode Random trigger shutter
Exposure control via ex-trigger input
Timing charts are shown below.
[TRIG timing: Positive (Rising edge detection)]

(5-3-2-1) CCU rear-panel DIP SW setting

Like normal shutter, shutter-speed (exposure-time) is selectable among 8 scales.

(5-3-2-2) TRIG signal pulse setting

- RDM selection is automatic with TRIG status.
- Don't set E-shutter SW in OFF under RTS mode.
RTS doesn't work if Electronic shutter speed SW is set in OFF position.

<Exposure time delay under RTS>

When the RTS is active, both in FIX mode and PULSE W mode, there is a time delay of approximately 1.4 micro s until the start of exposure after the rising edge of TRIG signal (positive).

<Exposure time under pulse width mode>

Under RTS pulse mode, the exposure time is determined by the pulse width. More exactly, the actual time is the pulse width plus approximately 19.1 micro s.

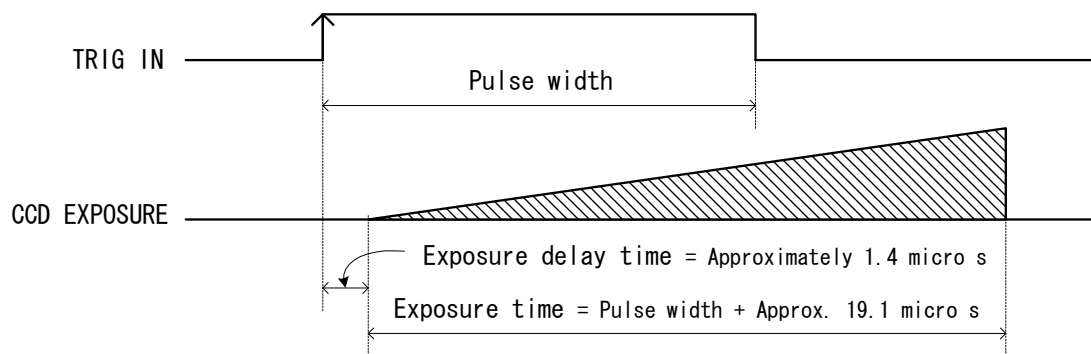

(a) Non-reset mode (Under internal-sync / external-sync --- Consecutive HD / VD IN)
 Exposure starts at the timing of TRIG signal IN. After each exposure is completed, the camera outputs video at each next VD IN timing.

(1/60s Non-interlace)

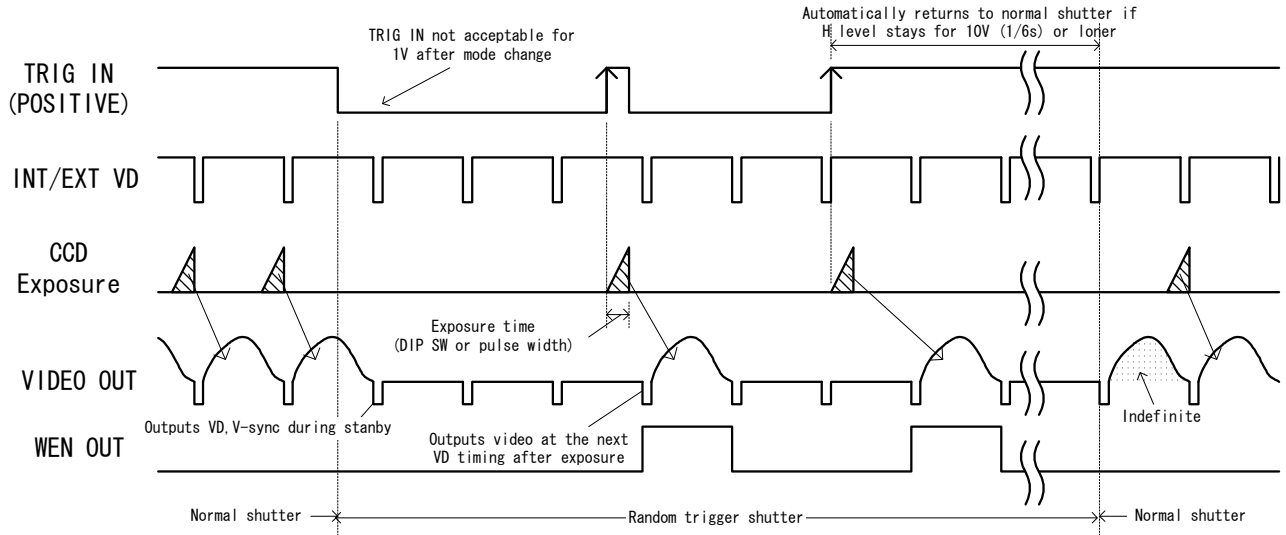

(1/120s 2:1 Interlace) **OPTION**

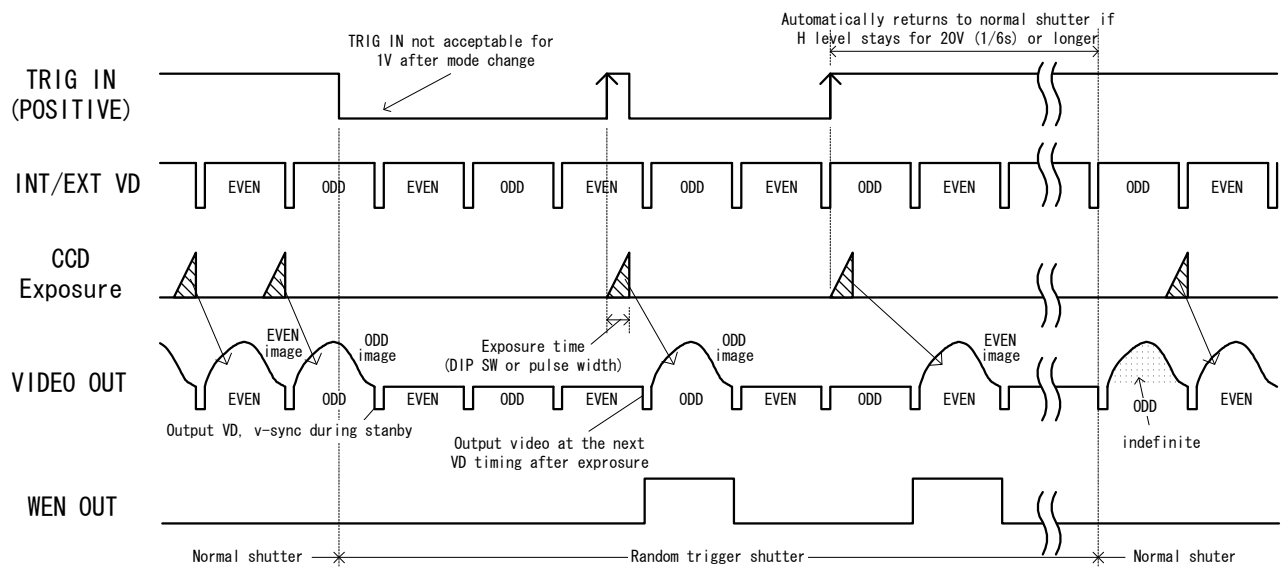

- The function/features noted as “option” or shown with the **OPTION** mark in this document is available as optional function/feature (= Production on order) and not provided as standard function. Please contact our sales staff for details.
- Under standard version, 1/120s 2:1 Interlace mode function is not available. (1/60s non-interlace mode only)

(b) Non-reset mode (Under external sync --- Single VD and Consecutive HD IN)
 After TRIG IN and exposure, the camera goes into standby until next external VD IN.

(1/60s Non-interlace)

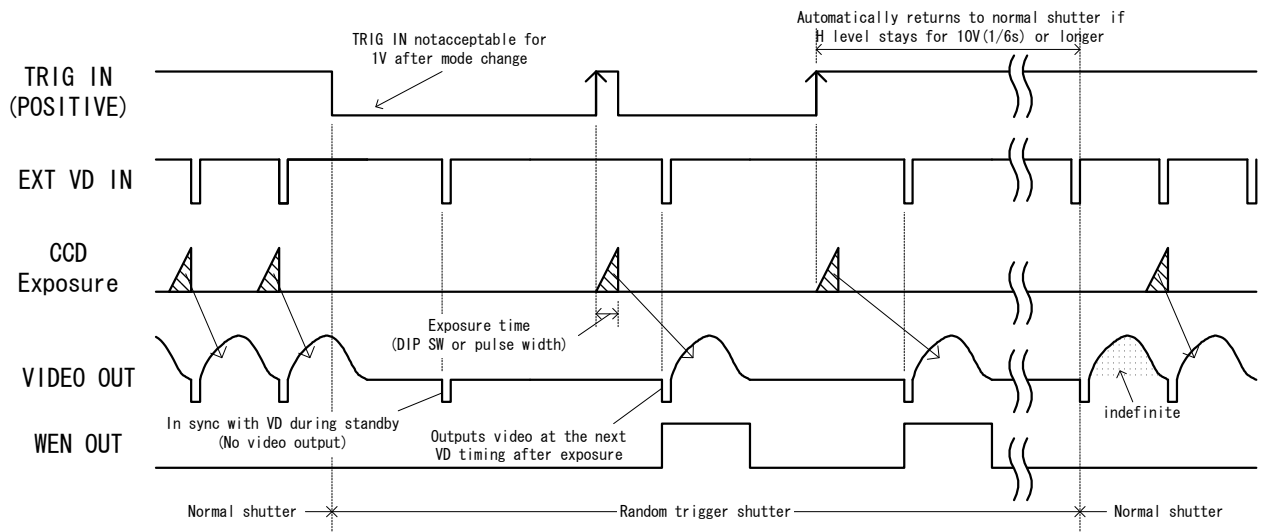

(1/120s 2:1 Interlace) **OPTION**

The video output field (ODD/EVEN) is determined by the phase difference between ex-VD falling edge and ex-HD.

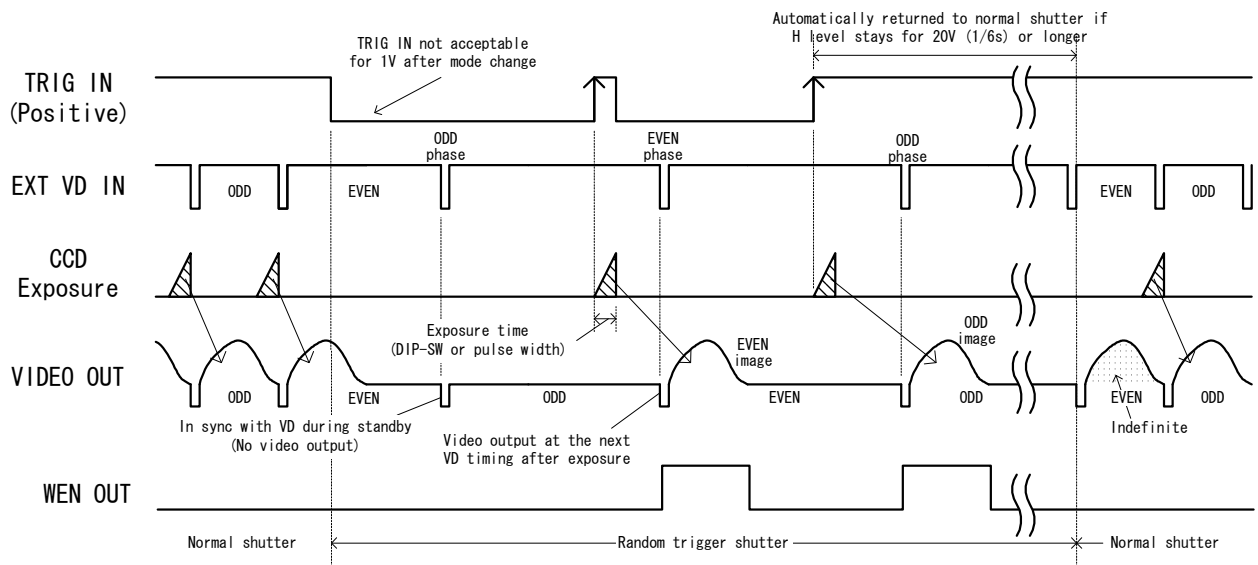

- The function/features noted as “option” or shown with the **OPTION** mark in this document is available as optional function/feature (= Production on order) and not provided as standard function. Please contact our sales staff for details.
- Under standard version, 1/120s 2:1 Interlace mode function is not available. (1/60s non-interlace mode only)

(c)V-reset mode (Under internal-sync / Consecutive HD IN)

Exposure starts at the timing of TRIG signal IN. After each exposure is completed, the camera outputs video immediately by resetting VD. (HD is not reset)

(1/60s Non-interlace)

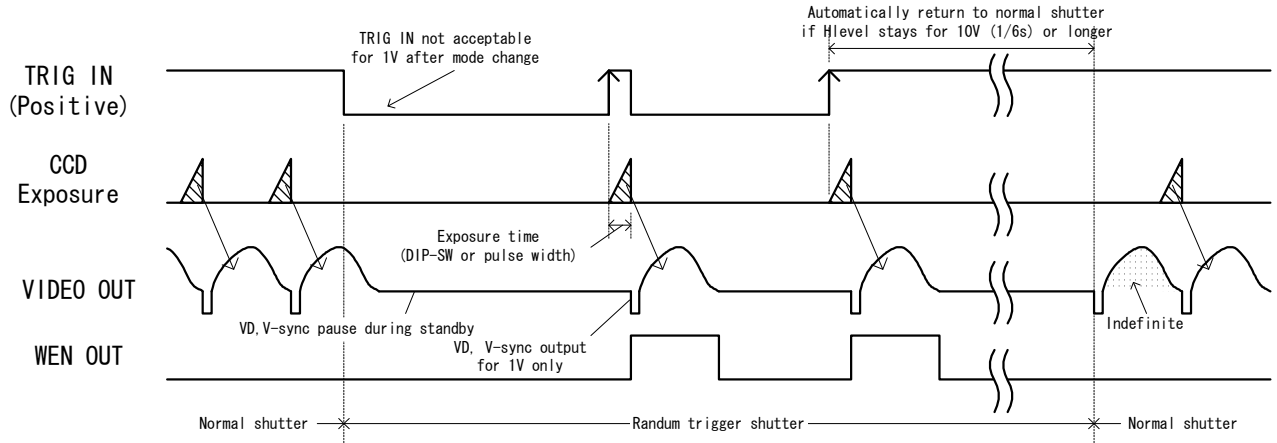

(1/120s 2:1 Interlace) **OPTION**

Irrespective of TRIG IN phase, the camera always outputs ODD field image.

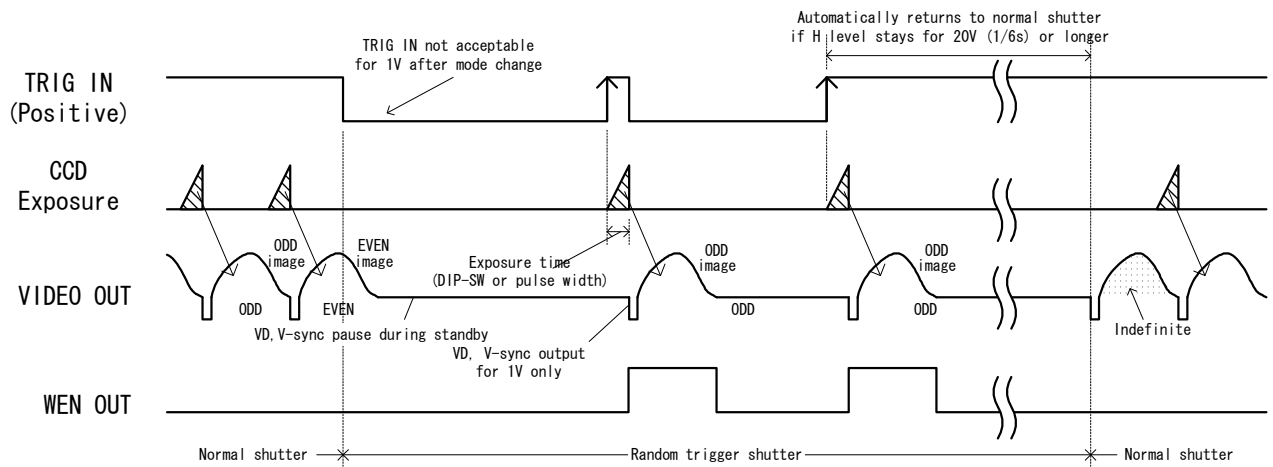

- The function/features noted as “option” or shown with the **OPTION** mark in this document is available as optional function/feature (= Production on order) and not provided as standard function. Please contact our sales staff for details.
- Under standard version, 1/120s 2:1 Interlace mode function is not available. (1/60s non-interlace mode only)

(5-3-3) Restart / Reset The restart / reset function is available with the external VD signal. You can get an arbitrary slower shutter speed than normal shutter and random trigger shutter.

- The shutter speed (exposure time) is determined by external VD signal interval.
- This function is enabled when the rear-panel shutter speed DIP SW is OFF.
- Supply consecutive HD.

(1/60s Non-interlace)

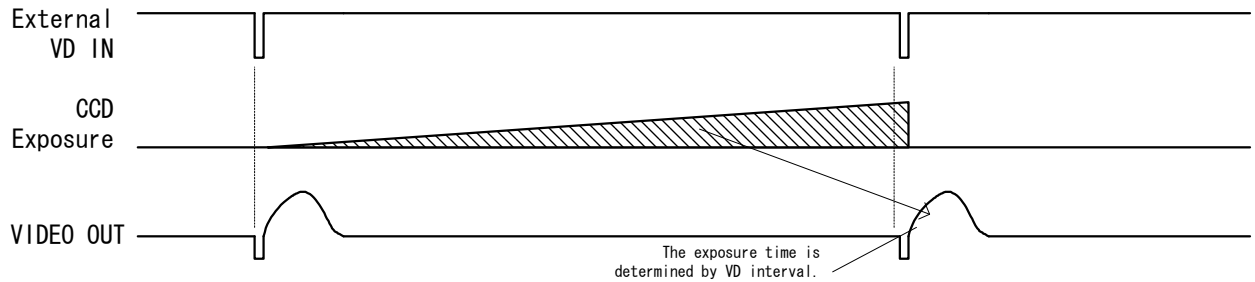

(1/120s 2:1 Interlace)

OPTION

The video output field (ODD/EVEN) is determined by the phase difference between the ex-VD falling edge and ex-HD.

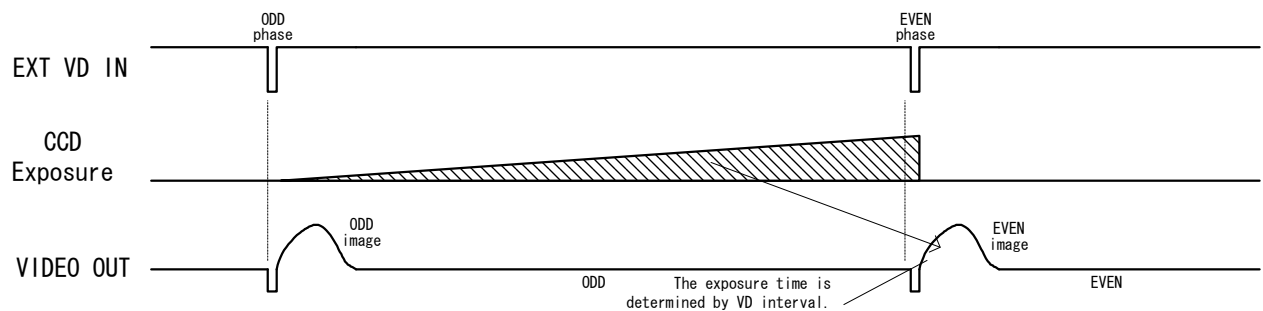

- The function/features noted as “option” or shown with the **OPTION** mark in this document is available as optional function/feature (= Production on order) and not provided as standard function. Please contact our sales staff for details.
- Under standard version, 1/120s 2:1 Interlace mode function is not available. (1/60s non-interlace mode only)

5.4 Partial-scan mode selection (CCU rear-panel DIP SW) OPTION

--- Switches partial-scan mode / There are 2 partial scan modes.

Note: Sometimes phenomenon called as “whiteout” occurs at the top of the screen when there is strong incident light entering in the wide area of a CCD, however, this is not a malfunction. If this occurs, reduce the amount of incoming rays.

(5-4-1)1/2 Partial-scan --- Screen center 1/2 readout OPTION

(1/60s 2:1 Non-interlace) OPTION

Under 1/60s non-interlace mode, only the center portion of 227H out of the total effective lines 494H (excluding BLK time) is read out. Available both under external / internal mode.

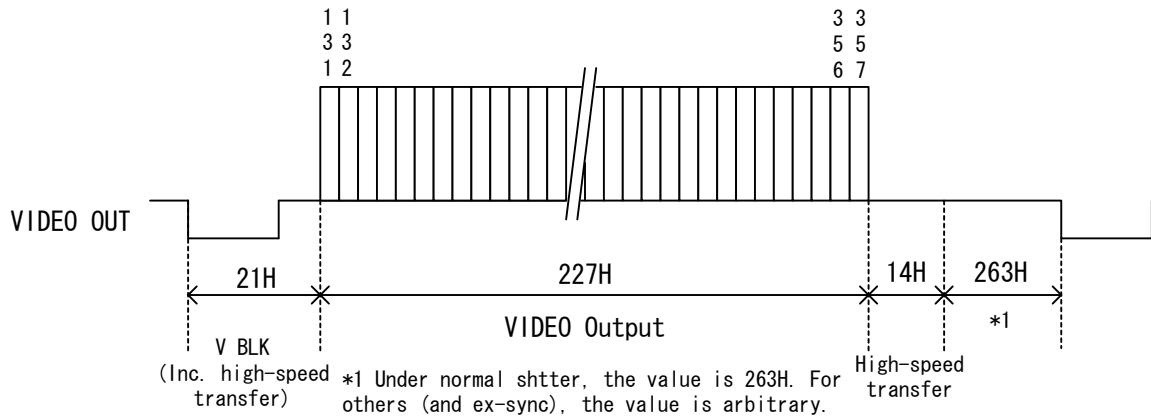
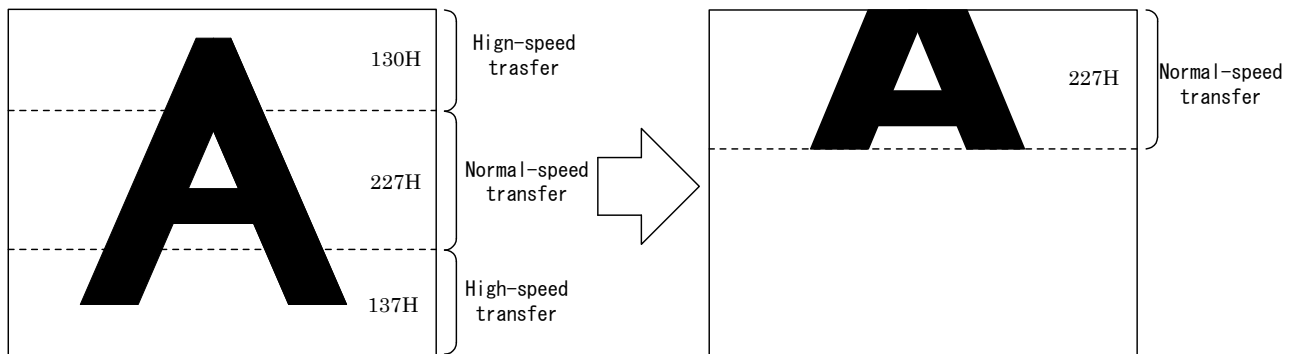

- The function/features noted as “option” or shown with the OPTION mark in this document is available as optional function/feature (= Production on order) and not provided as standard function. Please contact our sales staff for details.
- Under standard version, partial-scan function is not available. (Normal-scan mode only)

(1/120s 2:1 Interlace) **OPTION**

Under 1/120s interlace mode, only the center portion of 240H out of the total effective lines 485H (excluding BLK time) is read out. Available both under external / internal mode.

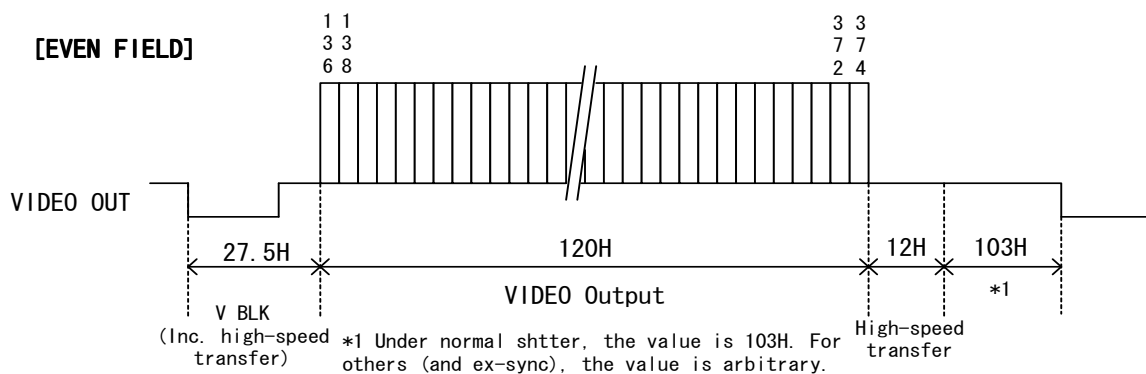
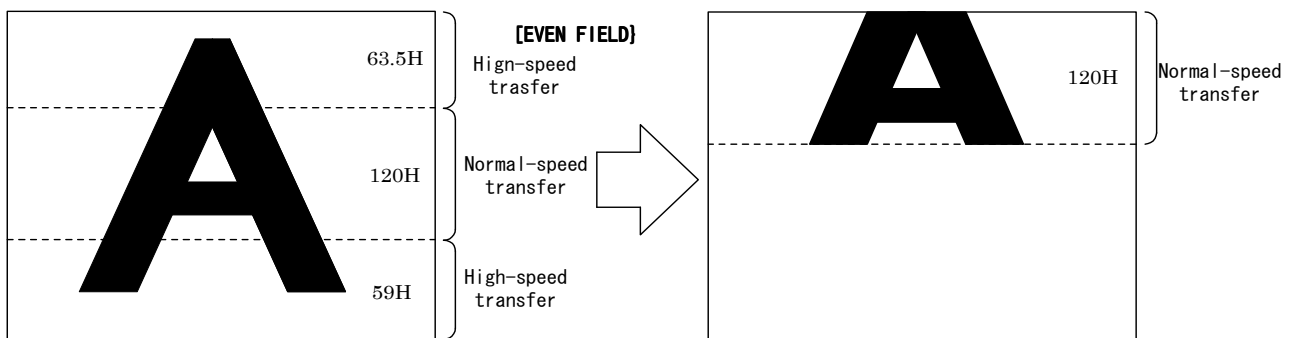
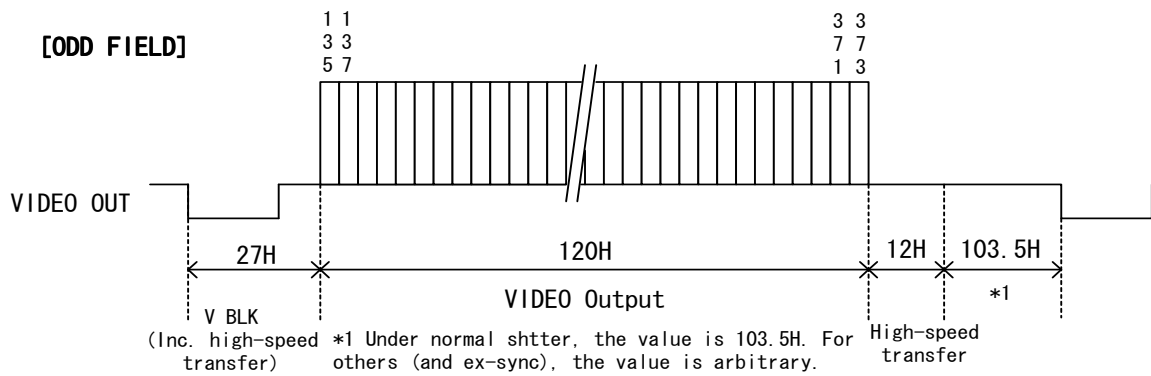
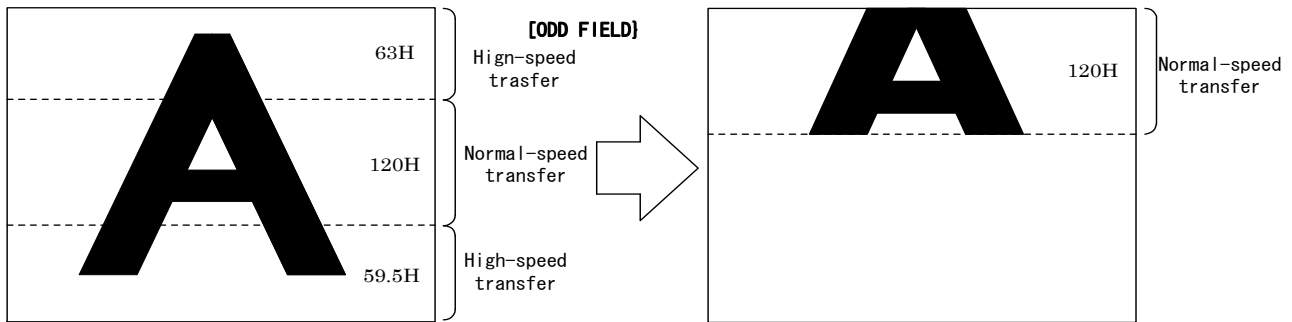

- The function/features noted as “option” or shown with the **OPTION** mark in this document is available as optional function/feature (= Production on order) and not provided as standard function. Please contact our sales staff for details.
- Under standard version, partial-scan function is not available. (Normal-scan mode only)
- Under standard version, 1/120s 2:1 Interlace mode function is not available. (1/60s non-interlace mode only)

(5-4-2) Programmable partial **OPTION**

By designating the high-speed transfer portion with external PARTIAL signal input, the camera read out only the portion of CCD area necessary for your application. This is available under external sync.

(1/60s Non-interlace mode) **OPTION**

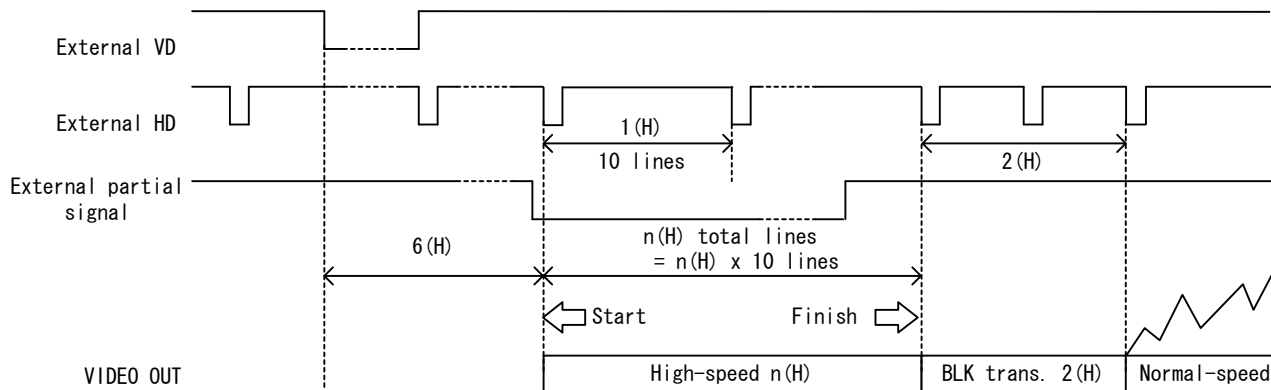

(Conditions)

- The starting point of external partial signal is 6H from the falling edge of ex-VD.
- The external partial signal is controlled at each ex-HD falling edge. Set the start / finish of the external partial signal in 1H increments.
- The number of 1H high-speed transfer line is 10 lines. The actual lines are determined by the external partial signal “Low” length. (Minimum: 2H = 20 lines)
- After high-speed transfer, 2H is allocated to blank transfer period. Normal transfer starts at the next line.
- VIDEO OUT vertical blanking is;

$$V \text{ blanking} = 6(H) + n(H) + \text{BLK transfer } [2(H)] - 1H$$

Example follows below.

(High-speed minimum 2H = 20 lines)

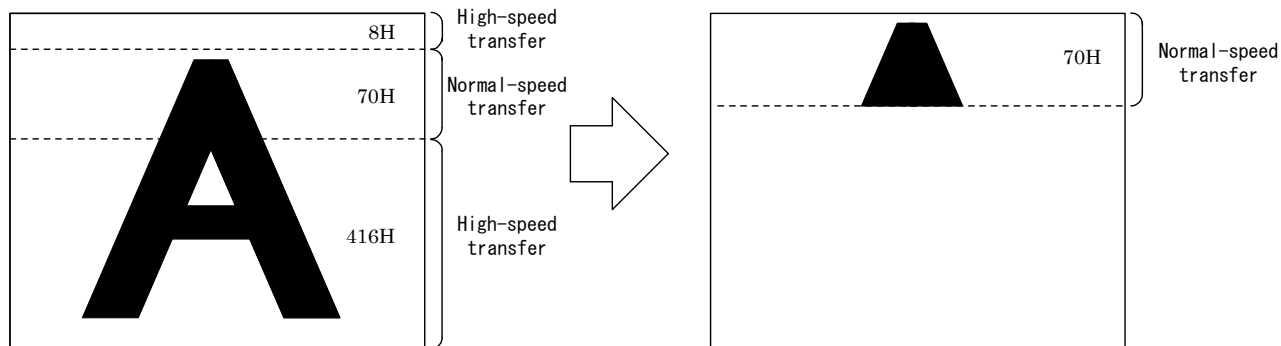

- The function/features noted as “option” or shown with the **OPTION** mark in this document is available as optional function/feature (= Production on order) and not provided as standard function. Please contact our sales staff for details.
- Under standard version, partial-scan function is not available. (Normal-scan mode only)

The timing is as follows; OPTION

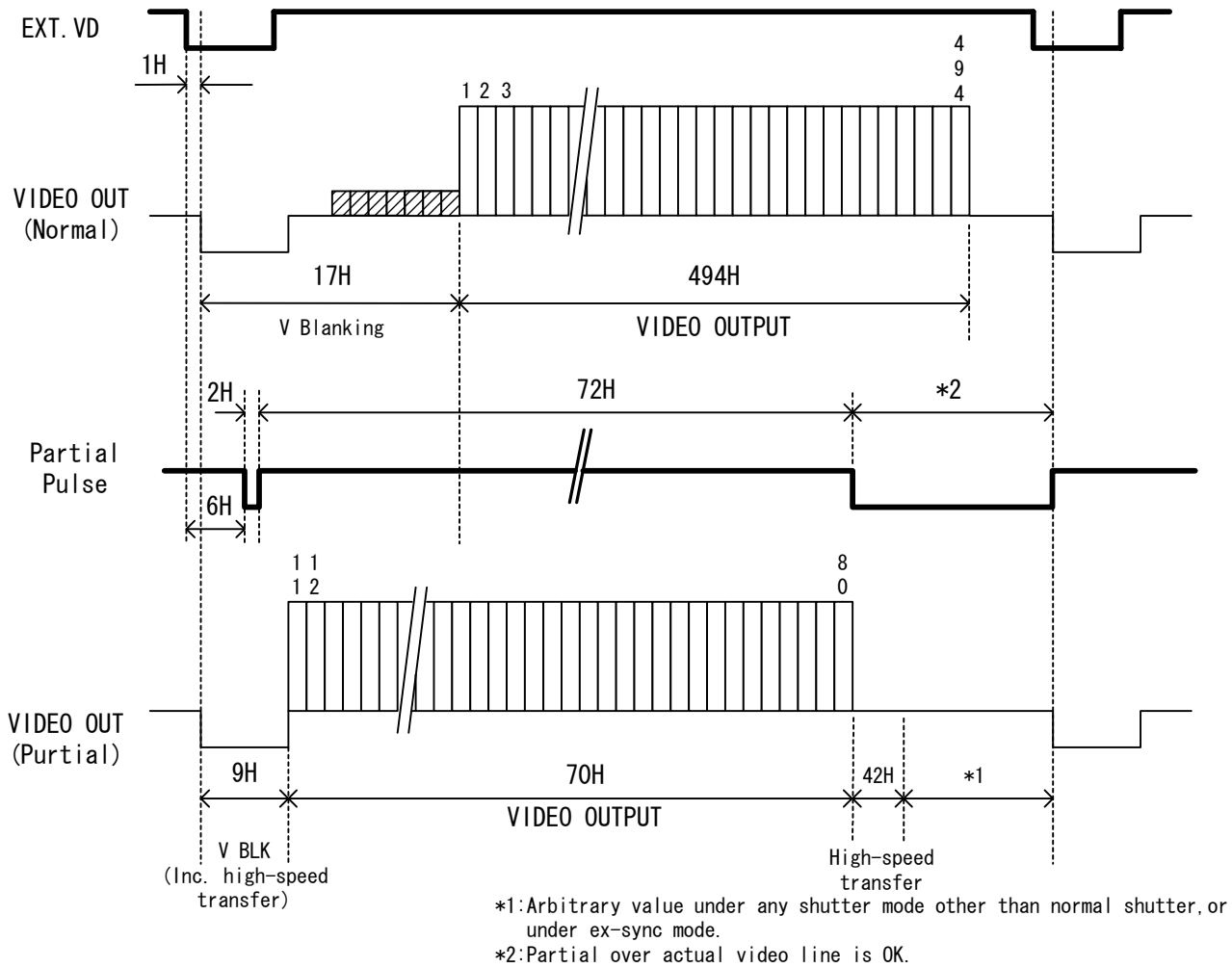

* BLK during no video output

- The function/features noted as “option” or shown with the OPTION mark in this document is available as optional function/feature (= Production on order) and not provided as standard function. Please contact our sales staff for details.
- Under standard version, partial-scan function is not available. (Normal-scan mode only)

(1/120s 2:1 Interlace mode) **OPTION**

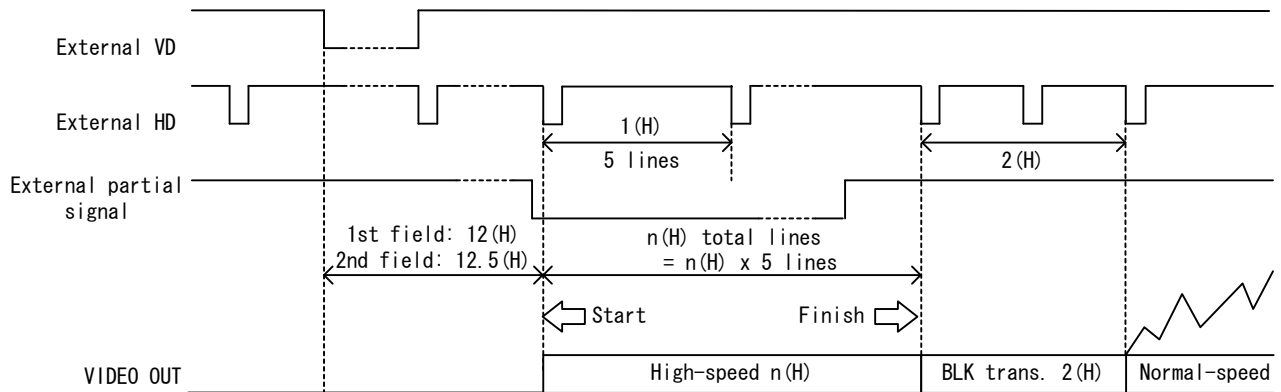

(Conditions)

- The starting point of external partial signal is 12/12.5H from the falling edge of ex-VD.
- The external partial signal is controlled at each ex-VD falling edge. Set the start / finish of the external partial signal in 1H increments.
- The number of 1H high-speed transfer line is 5 lines. The actual lines are determined by the external partial signal “Low” length. (Minimum: 1H = 5 lines)
- After high-speed transfer, 2H is allocated to blank transfer period. Normal transfer starts at the next line.
- VIDEO OUT vertical blanking is;
 $V \text{ blanking} = 12(H) + n(H) + \text{BLK transfer } [2(H)] - 1H$ [1st field]
 $V \text{ blanking} = 12.5(H) + n(H) + \text{BLK transfer } [2(H)] - 1H$ [2nd field]

Example follows below.

(High-speed minimum 1H = 5 lines)

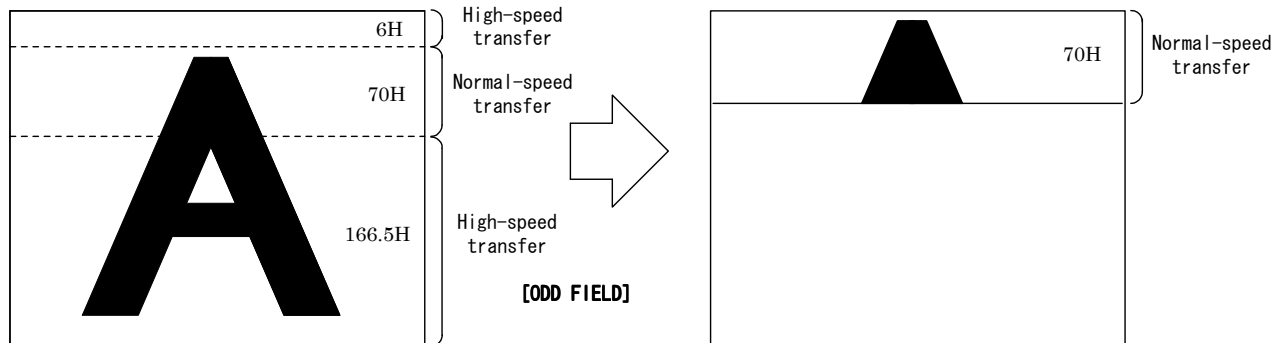

- The function/features noted as “option” or shown with the **OPTION** mark in this document is available as optional function/feature (= Production on order) and not provided as standard function. Please contact our sales staff for details.
- Under standard version, partial-scan function is not available. (Normal-scan mode only)
- Under standard version, 1/120s 2:1 Interlace mode function is not available. (1/60s non-interlace mode only)

(5-4-3) Partial-scan sync-signal reset **OPTION**

RTS Non-reset / V-reset selection can be made via camera CCU rear-panel DIP SW. The selection is also available under 1/2 partial scan operation.

(a) Non-reset **OPTION**

VD signal interval: 525H (1/60s non-interlace mode) / 262.5H (1/120s 2:1 Interlace mode)
Readout speed: Normal scan speed readout

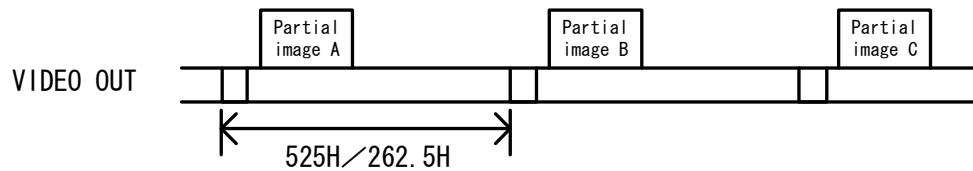

(b) V reset (E-shutter disabled) **OPTION**

The VD gets reset immediately after readout.

VD signal interval: 262H (1/60s non-interlace mode) / 159H (1/120s 2:1 Interlace mode),
Readout speed: Twice (x2) normal scan speed readout

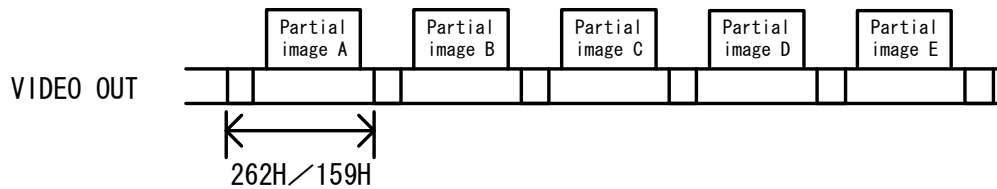

- The function/features noted as “option” or shown with the **OPTION** mark in this document is available as optional function/feature (= Production on order) and not provided as standard function. Please contact our sales staff for details.
- Under standard version, partial-scan function is not available. (Normal-scan mode only)
- Under standard version, 1/120s 2:1 Interlace mode function is not available. (1/60s non-interlace mode only)

6. Specifications

Model	CS3821D
[Basic spec]	
Image sensor	All Pixel's Data Read-out Interline CCD
Total pixels	692(H) x 504(V)
Active pixel	659(H) x 494(V)
Video output pixels	648(H) x 494(V) (1/60s Non-interlace) 648(H) x 485(V) (1/120s 2:1 Interlace) OPTION
Scanning area	4.88(H) x 3.66(V) mm (= Equivalent to 1/3 type CCD size)
Unit cell size	7.4(H) x 7.4(V) micro m (Square-grid array)
TV format	Special format (Not conforming to EIA)
Scanning lines	525 lines
Interlace	1/60s Non-interlace mode (Switching via rear-panel DIP SW) 1/120s 2:1 Interlace mode OPTION
Sync system	Internal/External automatic switch-over
Aspect ratio	4:3
Video output	VS 1.0V(p-p) / 75-ohm, 1 system DC / AC coupled (Switching via internal SW)
S/N	Standard: 52dB(p-p)/rms (Initial factory setting)
Resolution	485 TV lines(H) 485 lines(V) (1/60s Non-interlace)/ 350 TV lines(V) (1/120s 2:1 Interlace)
Illumination	Standard 400 lx (F5.6) Minimum 4.0 lx (F1.4)
Gain	FIX (Fixed) gain: Factory-shipped preset level MANU (Manual) gain: Setting through GAIN VR FIX / MANU switching via rear-panel DIP SW
Gamma correction	Gamma = 1 (Fixed)
White-clip level	Approx. 857mV(p-p) (Excluding SYNC)
Power source	DC12V plus/minus 10 percent Ripple voltage: Less than 50mV(p-p)
Power consumption	Approx. 3.0W
Camera cable	2m

* For avoid the troubles, check to see that the camera's power switch is turned off on the insertion and extraction of connectors.

** As the gain decrease when you use the optional camera cable(3.5m), it is necessary to readjust the gain at that time.

*** The camera head and CCU on the same serial number is recommended users to meet the inherent specifications of cameras.

- The function/features noted as "option" or shown with the OPTION mark in this document is available as optional function/feature (= Production on order) and not provided as standard function. Please contact our sales staff for details.
- Under standard version, 1/120s 2:1 Interlace mode function is not available. (1/60s non-interlace mode only)

[Internal sync spec]	
Base clock frequency	24.5454MHz (1CLK) plus/minus 200ppm
H sync frequency	31.468kHz (1H = 780CLK)
V sync frequency	59.94Hz (1V = 525H) (Under 1/60s non-interlace) 119.88Hz (1V = 262.5H) (Under 1/120s 2:1 interlace) OPTION

- The function/features noted as “option” or shown with the **OPTION** mark in this document is available as optional function/feature (= Production on order) and not provided as standard function. Please contact our sales staff for details.
- Under standard version, 1/120s 2:1 Interlace mode function is not available. (1/60s non-interlace mode only)

[External sync spec]	
Ex-sync. input signal	HD/VD
Input level	2~4V (p-p)
Input impedance	75-ohm / High impedance(10k-ohm) (switching via inner slide SW) (Initial factory setting: High)
Interlace	1/60s non-interlace or 1/120s 2:1 interlace OPTION
Polarity	Negative
Pulse width	HD: 3.2 plus/minus 1 micro s (LOW) VD: From 125 through 400 micro s (LOW)
Repeating frequency	$f_H = 31.468\text{kHz}$ plus/minus 1 percent $f_V = f_H/525$ or $f_V = f_H/262.5$ OPTION
Scanning lines	525 lines
Phase difference	HD/VD: 0 plus/minus 5 micro s, $1/f_H/2$ plus/minus 5 micro s (a)1/60s Non-interlace mode
<p style="text-align: right;">TP1 : 10.0 us TP2 : 5.0 us</p>	

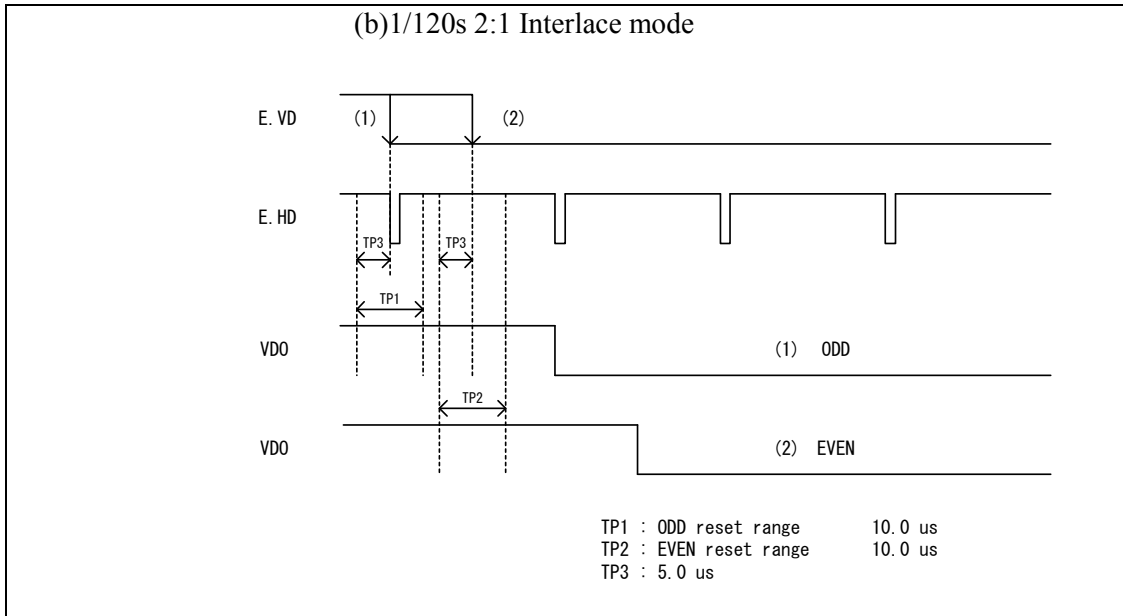

- The function/features noted as “option” or shown with the **OPTION** mark in this document is available as optional function/feature (= Production on order) and not provided as standard function. Please contact our sales staff for details.
- Under standard version, Video-out mode function is not available. (1/60s non-interlace mode only)

[Shutter trigger spec]	Exposure-starting-cue signal in random trigger shutter mode
Input level	LOW level: 0~0.5V HIGH level: 4~5V
Input impedance	High impedance (10k-ohm)
Capture timing	Rising edge detection (Positive) / Falling edge detection (Negative) (Switching via inner DIP SW) (Initial factory setting: Rising edge)
Pulse width	Under DIP SW setting: Minimum 2.5 micro s, Maximum 1/6s Under pulse width setting: Minimum 2.5 micro s, Maximum 1/8s

[E-shutter spec]																																	
(1)Normal shutter	Shutter-speed setting via rear-panel SW (Initial: OFF) Selection among 8 scales (= OFF, 1/200s, 1/500s, 1/1000s, 1/2000s,1/4000s, 1/8000s, 1/20000s)																																
(2)RTS Operation mode	<table border="1"> <thead> <tr> <th>No.</th> <th>Reset</th> <th>Exposure</th> <th>Sync</th> </tr> </thead> <tbody> <tr> <td>1</td> <td rowspan="6">Non-reset</td> <td rowspan="3">Rear SW (Fix mode)</td> <td>Internal</td> </tr> <tr> <td>2</td> <td>Consecutive HD / Consecutive VD IN</td> </tr> <tr> <td>3</td> <td>Consecutive HD / Single VD IN</td> </tr> <tr> <td>4</td> <td rowspan="3">TRIG pulse width (PULSE mode)</td> <td>Internal</td> </tr> <tr> <td>5</td> <td>Consecutive HD / Consecutive VD IN</td> </tr> <tr> <td>6</td> <td>Consecutive HD / Single VD IN</td> </tr> <tr> <td>7</td> <td rowspan="4">V-reset</td> <td rowspan="2">Rear SW (Fix mode)</td> <td>Internal</td> </tr> <tr> <td>8</td> <td>Consecutive HD IN</td> </tr> <tr> <td>9</td> <td>Internal</td> </tr> <tr> <td>10</td> <td>TRIG pulse width (PULSE mode)</td> <td>Consecutive HD IN</td> </tr> </tbody> </table>			No.	Reset	Exposure	Sync	1	Non-reset	Rear SW (Fix mode)	Internal	2	Consecutive HD / Consecutive VD IN	3	Consecutive HD / Single VD IN	4	TRIG pulse width (PULSE mode)	Internal	5	Consecutive HD / Consecutive VD IN	6	Consecutive HD / Single VD IN	7	V-reset	Rear SW (Fix mode)	Internal	8	Consecutive HD IN	9	Internal	10	TRIG pulse width (PULSE mode)	Consecutive HD IN
No.	Reset	Exposure	Sync																														
1	Non-reset	Rear SW (Fix mode)	Internal																														
2			Consecutive HD / Consecutive VD IN																														
3			Consecutive HD / Single VD IN																														
4		TRIG pulse width (PULSE mode)	Internal																														
5			Consecutive HD / Consecutive VD IN																														
6			Consecutive HD / Single VD IN																														
7	V-reset	Rear SW (Fix mode)	Internal																														
8			Consecutive HD IN																														
9		Internal																															
10		TRIG pulse width (PULSE mode)	Consecutive HD IN																														
	*RTS shutter mode automatically switches over through TRIG IN **RTS disabled under E-shutter OFF																																
(3)Restart / Reset	Restart / reset available via external VD signal (Switching via rear panel DIP SW, Initial OFF) Notes: *The exposure-time (shutter-speed) is determined by external VD interval. **Enabled when rear-panel DIP SW OFF. ***Provide consecutive HD.																																

[Sync signal spec]	WEN readout timing pulse
Output signal	WEN
Output signal level	More than 4V(p-p), Emitter follower output
Polarity	Positive
Pulse width	1V output sync Video output

The diagram shows two waveforms. The top waveform, labeled 'VIDEO OUT', is a video signal with a sync pulse. The bottom waveform, labeled 'WEN OUT', is a rectangular pulse that occurs during the sync interval of the video signal. Vertical dashed lines indicate the timing relationship between the two signals.

[Partial scan spec]	OPTION				
Input signal level	LOW: 0 ~ 0.5V HIGH: 4 ~ 5V				
Input impedance	High impedance (10k-ohm)				
Operation mode	(a)1/2 partial-scan (b)Programmable partial-scan(rear panel DIP SW selection)				
No	Scan mode	Sync	Reset	E-shutter	
1	1/2 partial-scan	Internal	Non-reset	Normal	Enabled
2			V-reset	RTS	
3		Consecutive HD VD IN	Non-reset	Enabled	
4		Consecutive HD IN	V-reset	Disabled	
5	Programmable partial-scan	Consecutive HD VD IN	Non-reset	Enabled	

- The function/features noted as “option” or shown with the **OPTION** mark in this document is available as optional function/feature (= Production on order) and not provided as standard function. Please contact our sales staff for details.
- Under standard version, partial-scan function is not available. (Normal-scan mode only)

[Mechanical spec]	
External dimension	Refer to the attached ex-view drawing
Weight	Camera head: Approximately 16g CCU: Approximately 120g
Lens mount	M15.5 (pitch 0.5) * with external threads and focus lock ring
GND / insulation	Circuit GND ~ Chassis electrically conducted

[Ambient condition]	Performance guaranteed:
	Temperature: From 0 through 40 degree C Humidity: From 30 through 90 percent (No condensing)
	Operation guaranteed:
	Temperature: From -5 through 45 degree C Humidity: From 10 through 90 percent (No condensing)
	Storage:
	Temperature: From -20 through 60 degree C Humidity: From 10 through 90 percent (No condensing)
EMC conditions (Electro-Magnetic Compatibility)	
EMI (Electro-Magnetic Interference) EN61000-6-4 (Examination level EN55011-A) Conformity	
EMS (Electro-Magnetic Susceptibility) EN61000-6-2 Conformity	

*** Conformity of an option part and EMC conditions**
 About the conformity of the EMC standard of this machine, it has guaranteed in the conditions combined with the above-mentioned option part.
 When used combining parts other than specification of our company, I ask you to have final EMC conformity checked of a visitor with a machine and the whole equipment.

[Connector pin assignment]																											
Compatible connector	HR10A-10P-12S (Supplied by HIROSE ELEC.)																										
Pin assignment																											
<table border="1"> <thead> <tr> <th>Pin No.</th> <th>Signal Name</th> </tr> </thead> <tbody> <tr><td>1</td><td>DC12V GND</td></tr> <tr><td>2</td><td>DC12V</td></tr> <tr><td>3</td><td>VIDEO GND</td></tr> <tr><td>4</td><td>VIDEO OUT</td></tr> <tr><td>5</td><td>HD GND</td></tr> <tr><td>6</td><td>HD IN</td></tr> <tr><td>7</td><td>VD IN</td></tr> <tr><td>8</td><td>TRIG GND</td></tr> <tr><td>9</td><td>TRIG IN</td></tr> <tr><td>10</td><td>WEN OUT</td></tr> <tr><td>11</td><td>TRIG IN</td></tr> <tr><td>12</td><td>VD GND</td></tr> </tbody> </table>	Pin No.	Signal Name	1	DC12V GND	2	DC12V	3	VIDEO GND	4	VIDEO OUT	5	HD GND	6	HD IN	7	VD IN	8	TRIG GND	9	TRIG IN	10	WEN OUT	11	TRIG IN	12	VD GND	<p>Connector pin layout</p> <p>12 pin male</p>
Pin No.	Signal Name																										
1	DC12V GND																										
2	DC12V																										
3	VIDEO GND																										
4	VIDEO OUT																										
5	HD GND																										
6	HD IN																										
7	VD IN																										
8	TRIG GND																										
9	TRIG IN																										
10	WEN OUT																										
11	TRIG IN																										
12	VD GND																										
<p>* For avoid the troubles, check to see that the camera's switch is turned off on the insertion and extraction of connectors.</p> <p>**Under Partial scan mode [OPTION], 9th pin is external partial IN. Under normal mode, be sure to input the TRIG signal to either 9th pin or 11th pin. (The 9th pin is connected with 11th pin at the inside. Therefore, if you input the TRIG signal to 11th pin, be sure to use the 9th pin as OPEN.)</p>																											
<p>Normal</p> <table border="1"> <thead> <tr> <th>Pin No.</th> <th>Signal Name</th> </tr> </thead> <tbody> <tr> <td>9</td> <td>TRIG IN</td> </tr> </tbody> </table>	Pin No.	Signal Name	9	TRIG IN	<p>Option</p> <table border="1"> <thead> <tr> <th>Pin No.</th> <th>Signal Name</th> </tr> </thead> <tbody> <tr> <td>9</td> <td>PARTIAL IN</td> </tr> </tbody> </table>	Pin No.	Signal Name	9	PARTIAL IN																		
Pin No.	Signal Name																										
9	TRIG IN																										
Pin No.	Signal Name																										
9	PARTIAL IN																										

- The function/features noted as “option” or shown with the **[OPTION]** mark in this document is available as optional function/feature (= Production on order) and not provided as standard function. Please contact our sales staff for details.
- Under standard version, partial-scan function is not available. (Normal-scan mode only)

[SW Setting]

(1) CCU rear-panel DIP SW

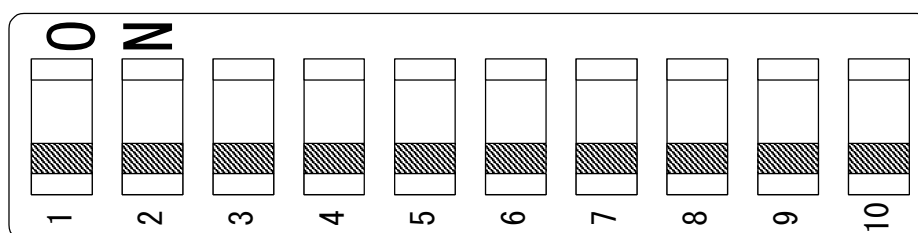

No.	SW Function	SW Status	Selected Function
1	E shutter-speed setting (ED)	—	Please refer to the E shutter-speed table (Table 1)
2			
3			
4	GAIN selection (GAIN.SW)	<u>OFF</u>	Factory setting
		ON	Setting via GAIN potentiometer
5	RTS mode setting (SMD)	<u>OFF</u>	Non-reset
		ON	V reset
6	Exposure time selection (EXP)	<u>OFF</u>	DIP switch setting
		ON	TRIG pulse width
7	Restart/Reset mode selection (R.R)	<u>OFF</u>	Disabled
		ON	Enabled
8	VIDEO output mode selection (VIDEO.MD) OPTION	<u>OFF</u>	1/60s non-interlace mode
		ON	1/120s 2:1 interlace mode
9	Scan mode selection (SCAN.MD) OPTION	<u>OFF</u>	Normal scan
		ON	Partial scan
10	Partial-scan mode selection (PARTIAL) OPTION	<u>OFF</u>	1/2 Partial scan mode
		ON	Programmable partial scan mode

[NOTES]

- The factory setting is shown with boldface underlined font.
- The function shown with the OPTION mark in this document is available as optional function (= Production on order) and not provided as standard function. Please contact our sales staff for details.
- Under standard version, Video-out mode function is not available. (1/60s non-interlace mode only)
- Under standard version, partial-scan function is not available. (Normal-scan mode only)

(Table 1) E-shutter speed setting

E-shutter speed	No.1	No.2	No.3
OFF	<u>OFF</u>	<u>OFF</u>	<u>OFF</u>
1/200s	ON	OFF	OFF
1/500s	OFF	ON	OFF
1/1,000s	ON	ON	OFF
1/2,000s	OFF	OFF	ON
1/4,000s	ON	OFF	ON
1/8,000s	OFF	ON	ON
1/20,000s	ON	ON	ON

[NOTES]

- Don't set E-shutter SW in OFF under RTS mode.
- The factory setting is shown with boldface underlined font.

(2) CCU inner SW
 (a) Ex-sync input impedance

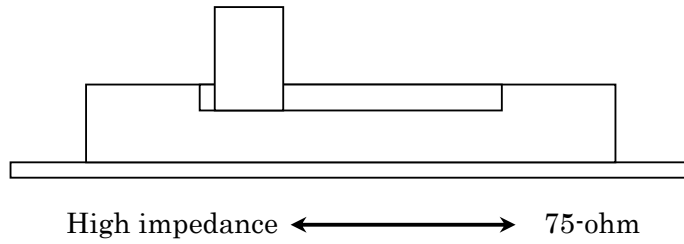

No.	SW Function	SW Status	Selected Function
1	Ex-sync input impedance SW	<u>High</u>	High impedance
		75	75-ohm

[NOTES]

- The factory setting is shown with boldface underlined font.
- This SW is mounted on the bottom circuit board.

(b) External trigger signal input polarity / External synchronization signal (WEN) polarity

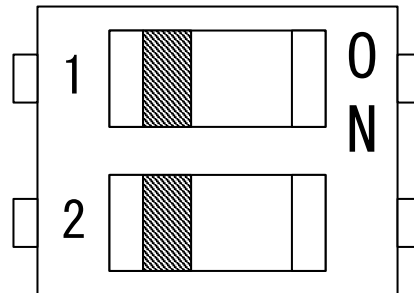

No.	SW Function	SW Status	Selected Function
1	Ex-trigger signal input polarity selection SW	<u>OFF</u>	Positive (Rising-edge)
		ON	Negative (Falling-edge)
2	Ex-sync signal (WEN) polarity selection SW	<u>OFF</u>	Positive
		ON	Negative

[NOTES]

- The factory setting is shown with boldface underlined font.
- This SW is mounted on the top circuit board.

(c) VIDEO OUTPUT DC / AC coupled selection

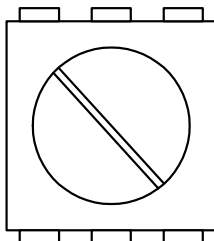

No.	SW Function	SW Status	Selected Function
1	Video out coupled selection	<u>Right turn</u>	DC coupled out
		Left turn	AC coupled out

- The factory setting is shown with boldface underlined font.
- This SW is mounted on the top circuit board.

7. Supplemental Drawings

7.1 Relative spectrum Response

(Including lens characteristics, not including light source characteristics)

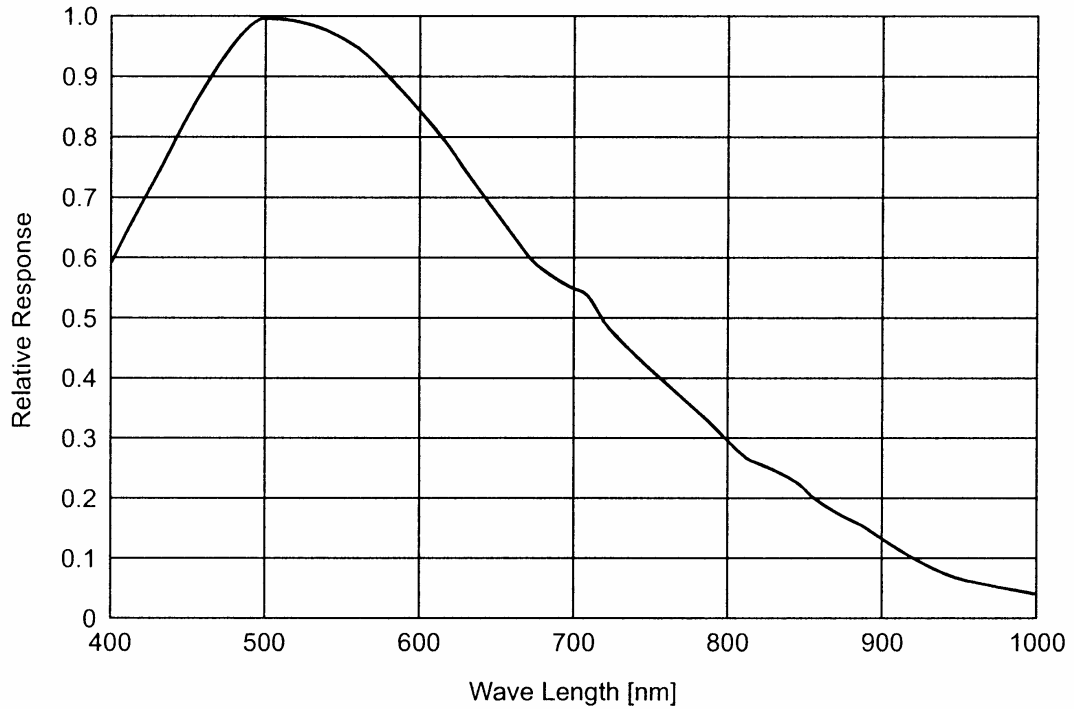

7.2 Optical black layout (Top-view)

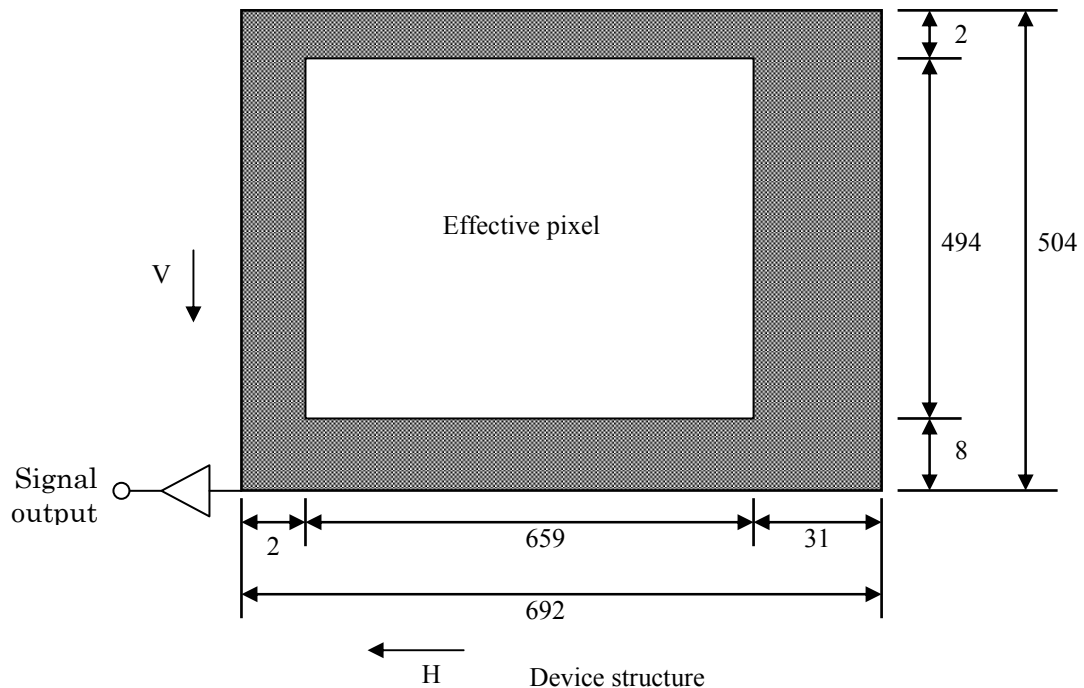

Device structure

Total pixels: 692(H) x 504(V)

Effective pixels: 659(H) x 494(V)

Optical black:

Horizontal: 2 pixels, 31 pixels

Vertical: 8 pixels, 2 pixels

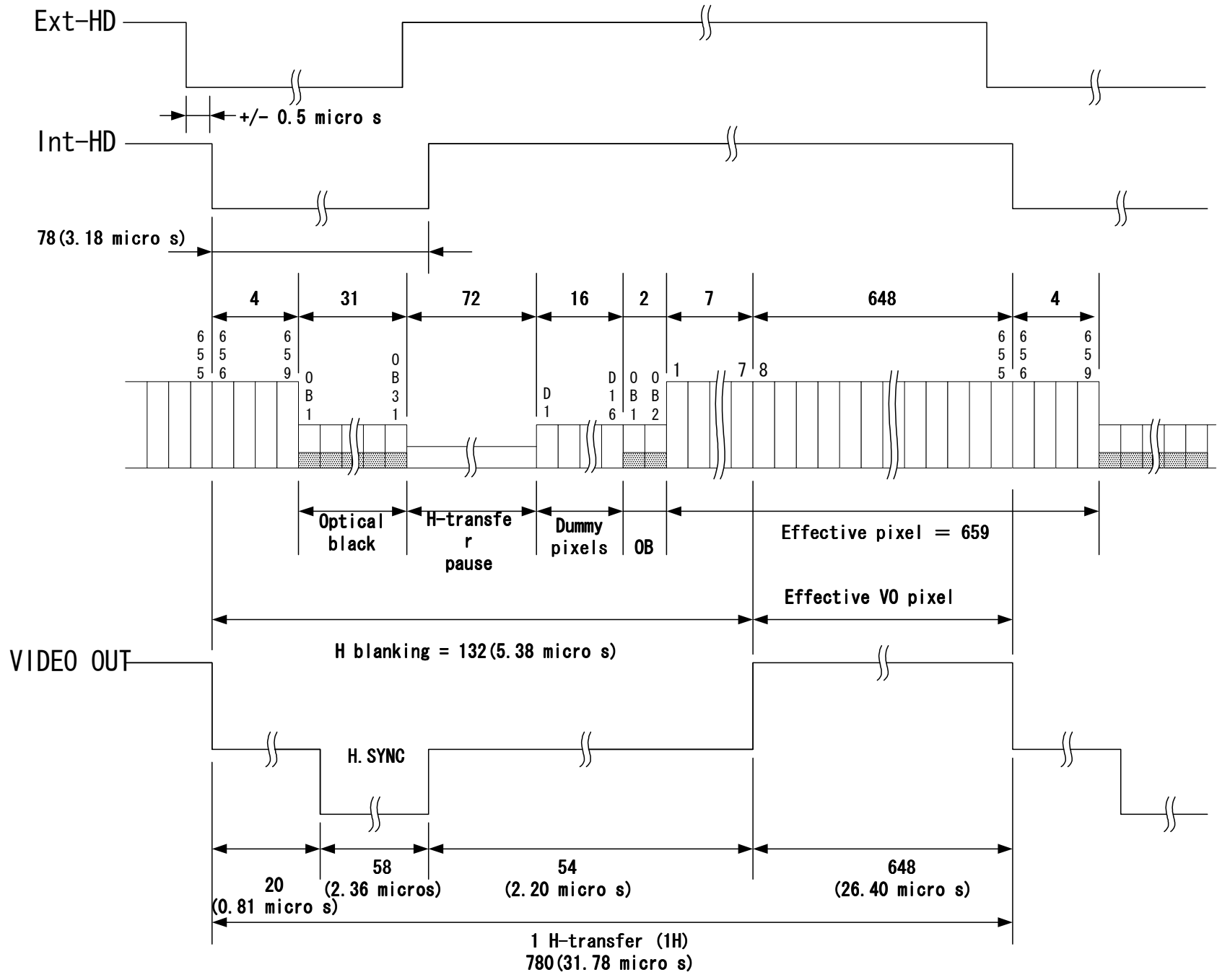

7.3 Output waveform timing chart (H)

7.4 Output waveform timing chart (V)

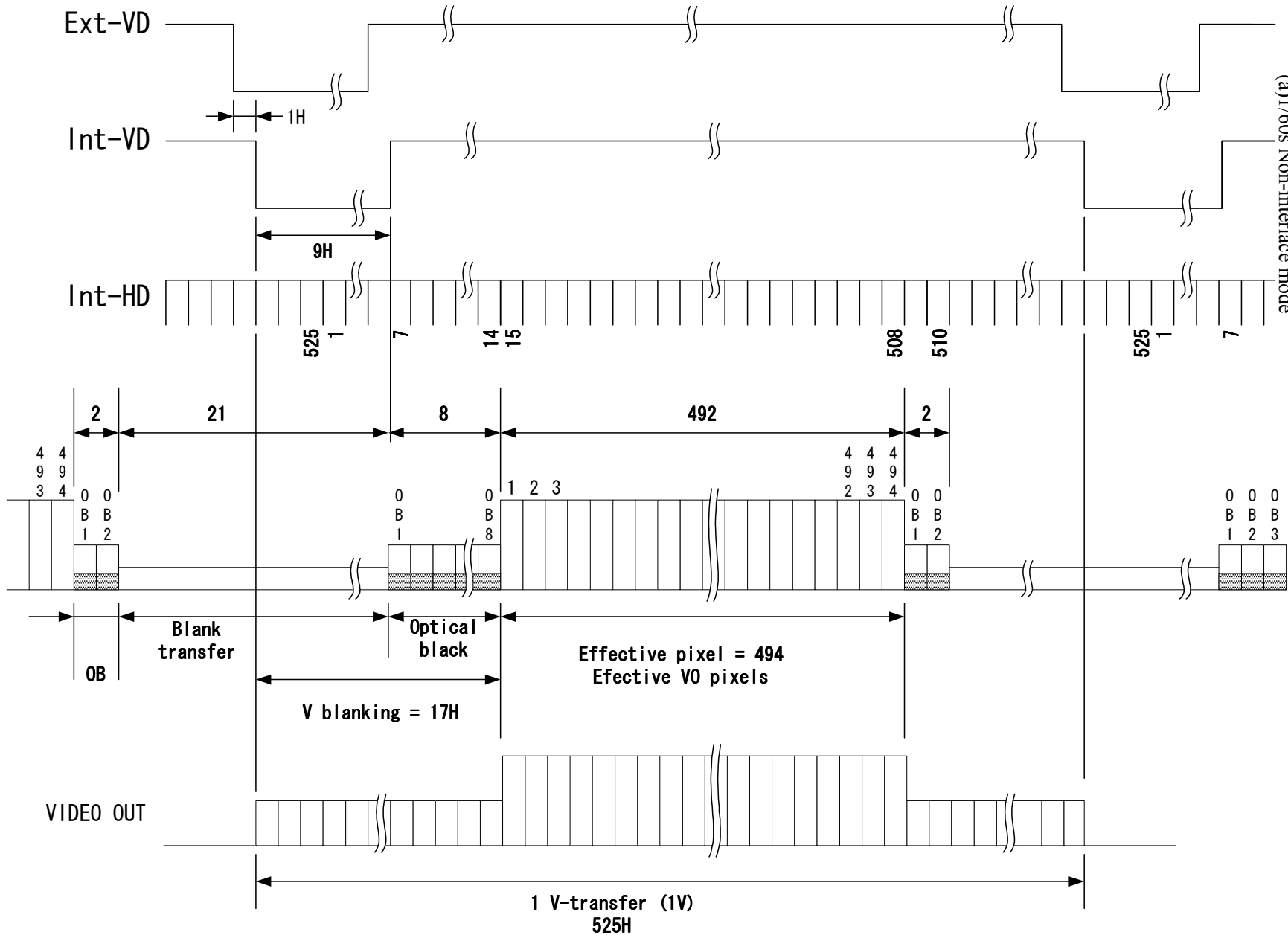

7.5 Camera head external-view

Main Material ; Anti-corrosive Aluminum

Finish ; Black anodic oxide coating

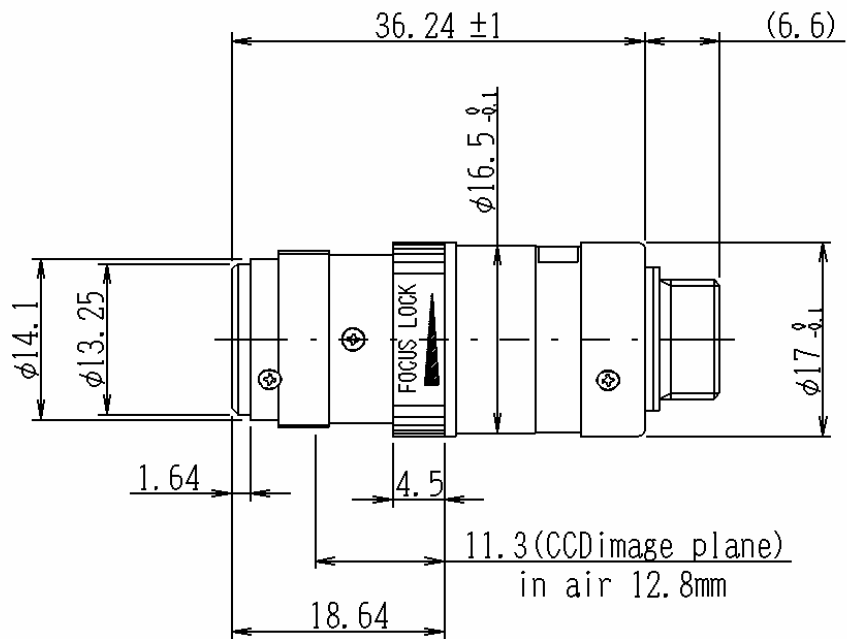
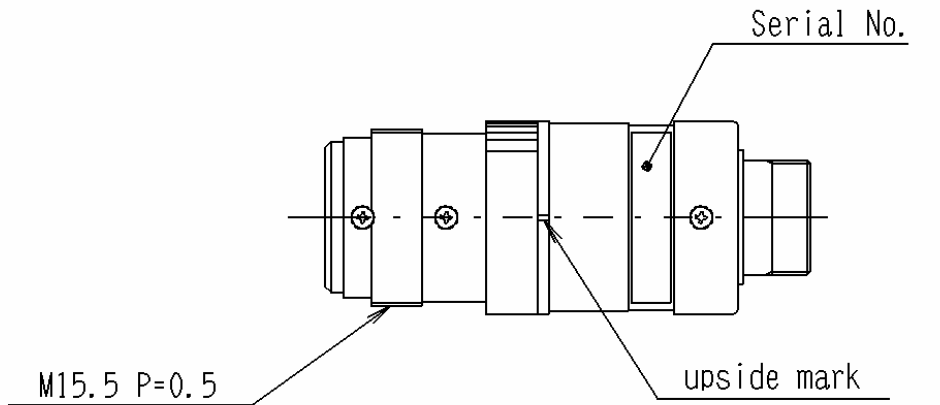

7.6 Camera cable external-view

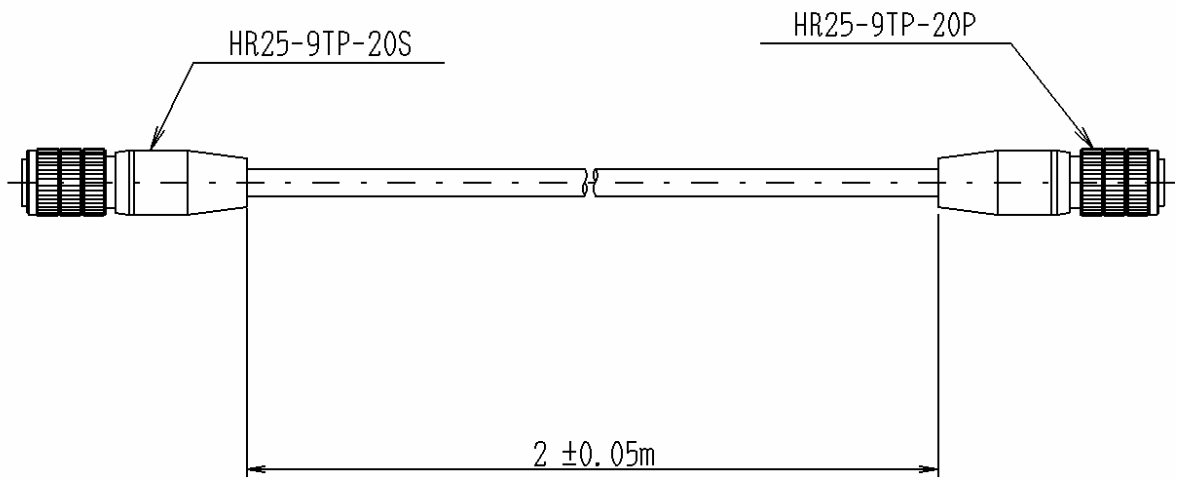

7.7 CCU external-view

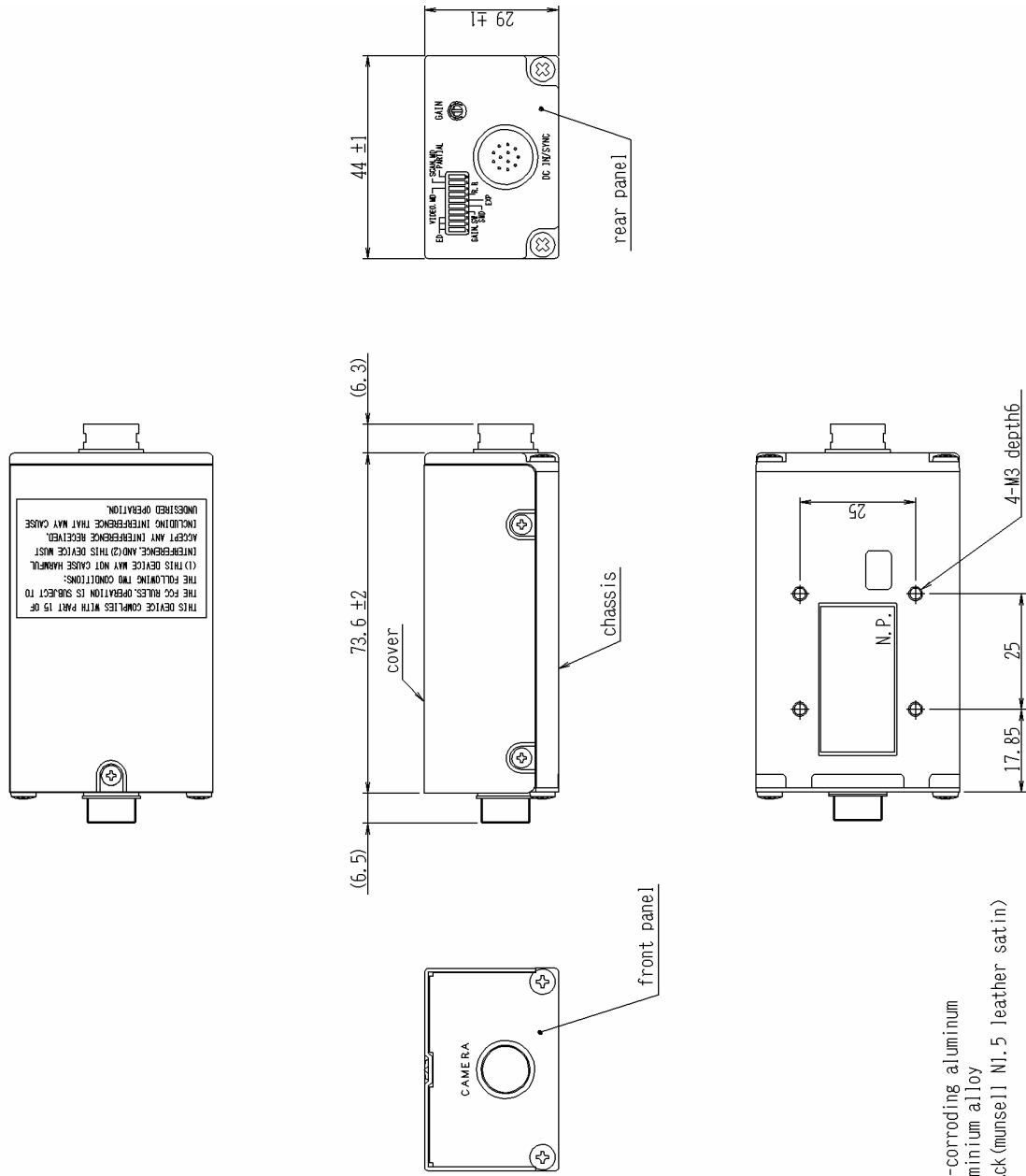

Specifications

chassis, rear panel non-corroding aluminum
 front panel, cover aluminum alloy
 color black (munsell Ni.5 leather satin)

The design and specification is subject to change without notice.