



High-resolution CCD Camera

Model CS3920

PRODUCT SPECIFICATION

CONTENTS

1. PRODUCT DESCRIPTION	1
2. FEATURES	1
3. CONFIGURATION	1
4. OPTIONAL ACCESSORIES	1
5. CONNECTION	2
6. SETTING	3
7. SPECIFICATIONS	5
8. TIMING CHART	6
9. EXTERNAL-VIEW DRAWING	10

TOSHIBA TELI CORPORATION

1. Product description

Model CS3920 is an integrated (one-body) type B/W CCD camera employing a 1/2" type frame-read-out CCD, featuring its ultra-high resolution of active 2,000,000 pixels.

2. Features

(1) Ultra-high resolution

CS3920 features an ultra-high picture resolution through the adoption of a MEGA-pixel CCD (Total pixel counts: 2,100,000 Active pixel counts: 2,000,000 [1,636(H)×1,236(V)]).

(2) Square grid pattern CCD

Pixel's in this CCD are aligned in square grid pattern. This makes it easier to perform computation correctly for image processing use.

(3) Random trigger shutter function

Random trigger shutter, which starts light-exposure in synchronization with external trigger signals, is build in. This function enables the camera to capture images at any given timing. Shutter speed is selectable among 8 scales, from 1/30s through 1/10000s.

(4) Digital output

Other than conventional analog output, digital output (EIA-644 single channel 10 bit) is also available.

(5) High-speed draft mode

By reading out just 2 lines out of total 8 lines, pixel data in all effective image area are read out in just 1/4 of the time needed under frame read-out mode. Under the high-speed draft mode, output lines will be 325 lines.

3. Configuration

(1) Camera body	1
(2) Accessory	
Operation Manual	1

4. Optional accessories

(1) Cable A (DC IN cable)	1
(2) Cable B (Digital video cable)	1
(3) Camera mounting kit	1
(4) Up-converter (Separate unit) (CSA3900)	1

5. Connection

(1)DC IN/SYNC

Connector (Camera side): HR10A-7R-6PB (Manufactured by HIROSE DENKI)

Plug (Cable side): HR10A-7P-6S (Manufactured by HIROSE DENKI)

Pin number	Signal name
1	VIDEO
2	VIDEO.GND
3	GND
4	TRIG
5	WEN
6	+12V

(2)DATA OUT

Connector (Camera side): DX10A-28S

(Cable side): DX30A-28P, DX-28-CV1 (Cover)

Pin.	Signal name	Pin.	Signal name	Pin.	Signal name	Pin.	Signal name
1	DATA0-H	8	DATA3-L	15	DATA7-H	22	VD-L
2	DATA0-L	9	DATA4-H	16	DATA7-L	23	HD-H
3	DATA1-H	10	DATA4-L	17	DATA8-H	24	HD-L
4	DATA1-L	11	DATA5-H	18	DATA8-L	25	CLK-H
5	DATA2-H	12	DATA5-L	19	DATA9-H	26	CLK-L
6	DATA2-L	13	DATA6-H	20	DATA9-L	27	TRIG IN
7	DATA3-H	14	DATA6-L	21	VD-H	28	GND

DATA0: LSB, DATA9: MSB

6. Setting

Setting of each mode can be done with SW1 on PROCESS board (the top board inside). To select modes, slide DIP switches numbered 1 through 8. The status is OFF when SW is in left position, ON when in right position.

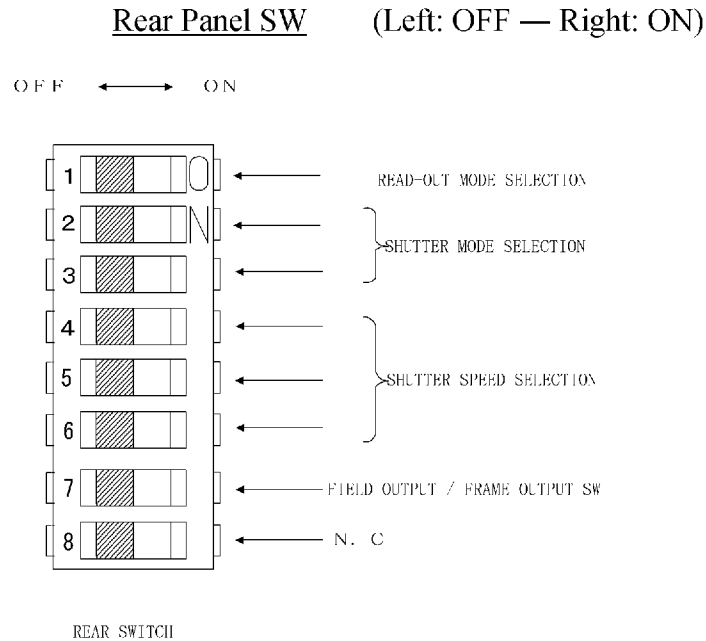

IMPORTANT

Before removing / putting back the cover for DIP SW mode setting, make sure to turn power SW OFF.

(1) Read-out Mode Setting (SW1 DIP1) (Initial-Factory-Setting: OFF)

OFF: 7.5Hz FRM Read-out Mode (Normal mode)

ON: 30Hz Quad-Speed Scan Mode (As only 2 lines out of 8 lines are read-out under this mode, vertical resolution is reduced to 1/4)

(2) Shutter Mode Setting (SW1 DIP2&3) (Initial-Factory-Setting: DIP2 ON, DIP3 OFF)

DIP2	DIP3	Shutter Mode
OFF	OFF	Shutter OFF
ON	OFF	Normal Electronic Shutter
OFF	ON	RTS Pulse Mode
ON	ON	RTS Fix Mode

(3) Shutter Speed (SW1 DIP4, 5&6) (Initial-Factory-Setting: DIP4, 5&6 OFF)

DIP4	DIP5	DIP6	Shutter Speed
OFF	OFF	OFF	1/30s
ON	OFF	OFF	1/60s
OFF	ON	OFF	1/125s
ON	ON	OFF	1/250s
OFF	OFF	ON	1/1000s
ON	OFF	ON	1/2000s
OFF	ON	ON	1/5000s
ON	ON	ON	1/10000s

(4) FLD Output / FRM Output Selection (SW1 DIP7) (Initial-Factory-Setting: OFF)

OFF: Field output

ON: Frame output

Under OFF (= FLD) setting, only the 1st field data is output in response to one trigger input. Under ON (= FRM) setting, both the 1st and 2nd field (=1 frame) data are output in response to one trigger input. Under the FRM output setting, CCD exposure is done twice inside the camera. This causes 1-field timing delay.

(5) RTS (Random Trigger Shutter) Pulse Control

The camera starts light-exposure at the TRIG signal falling-edge timing. The exposure-time is determined by pulse length. Be sure to set the pulse interval longer than 1H (approximately 103 μ s). The TRIG interval should be set longer than 2V (approximately 133ms).

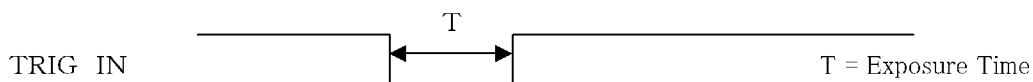

7. Specifications

Model	CS3920
TV system	Non standard
Image sensor	FRM readout CCD
Total pixel	1688(H)×1248(V)
Active pixel	1636(H)×1236(V)
Unit cell size	3.9(H)×3.9(V)μm
Optical size	1/2 type equivalent
Scanning system Interlace	
Scanning frequency	9.74kHz(H) 15Hz(V) or 30Hz(V)(30Hz under High-speed Draft Mode)
Aspect ratio	4:3
Sync system	Internal fixed
Illumination	Standard 400 lx (F4 3200K)
S/N	50dB
Video output	Digital output: EIA-644 Data: 10bit (18MHz) Analog output: 1.0V(p-p)/75Ω (Unbalanced)
Signal output	WEN: 4V(p-p), 1 st FLD positive HD: EIA-644 VD: EIA-644
External trigger input	4.0V(p-p) (Negative) Input impedance: 10kΩ Pulse interval (width): More than 103μ s
γ correction	OFF (γ=1.0)
Shutter speed	8 scales, 1/30s ~ 1/10000s
Lens mount	C mount
Power source	DC12V±10%
Power consumption	Approx. 2.3W
Ambient condition	Temperature : 0~40°C Humidity : 10~90% (No condensation)
External dimension	44(W)×29(H)×88(D)mm
Mass	Approx. 135g

8. Timing chart

8-1. Video output timing

(1) Under normal operation (Electronic shutter) (Frame readout: Interlace)

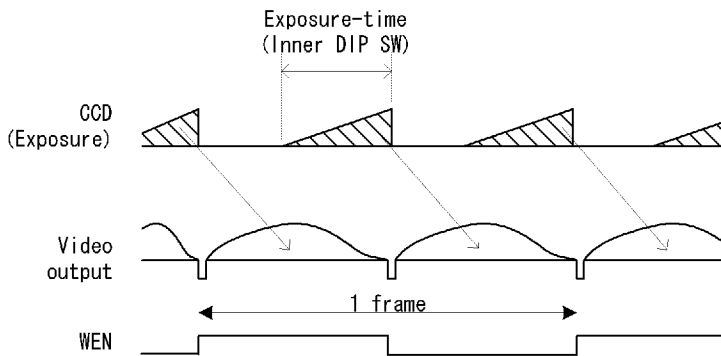

(2) Under random trigger shutter operation (Frame output)

(Under this mode, 1-frame video is output. As the camera performs twice exposure under this mode, this mode is suited for still-image shooting)

-1. Fixed speed mode

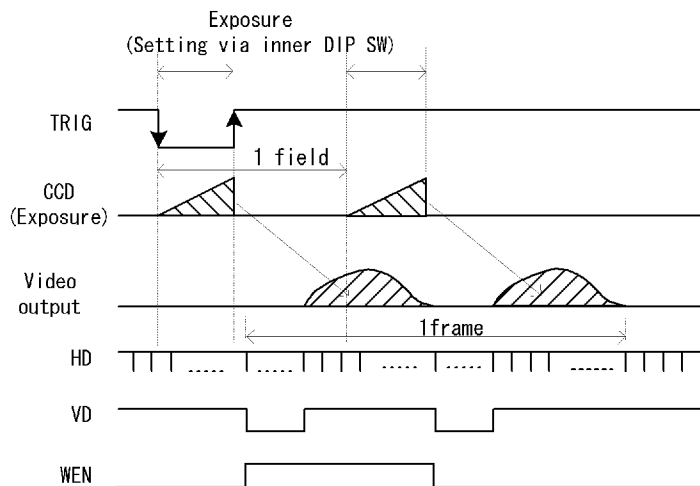

-2. Pulse mode (Frame output)

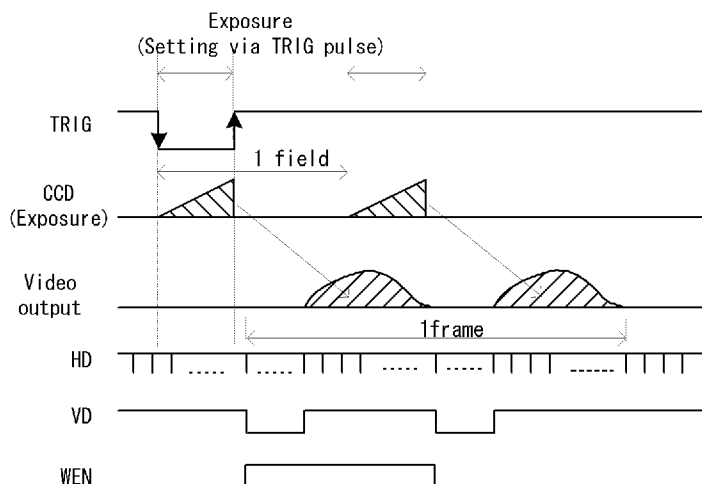

(3) Under random trigger shutter operation (Field output)

(Under this mode, only 1-field video is output after one exposure. This mode is suited for moving-subject shooting, but vertical resolution will be reduced into half)

-1. Fixed speed mode (1FLD output)

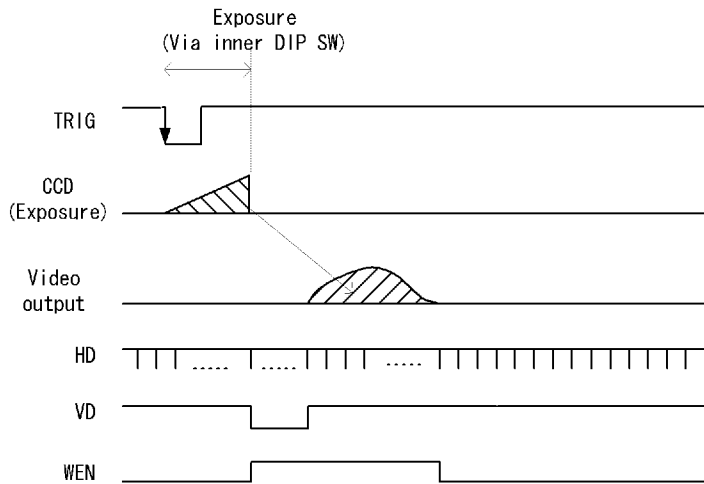

-2. Pulse mode (1FLD output)

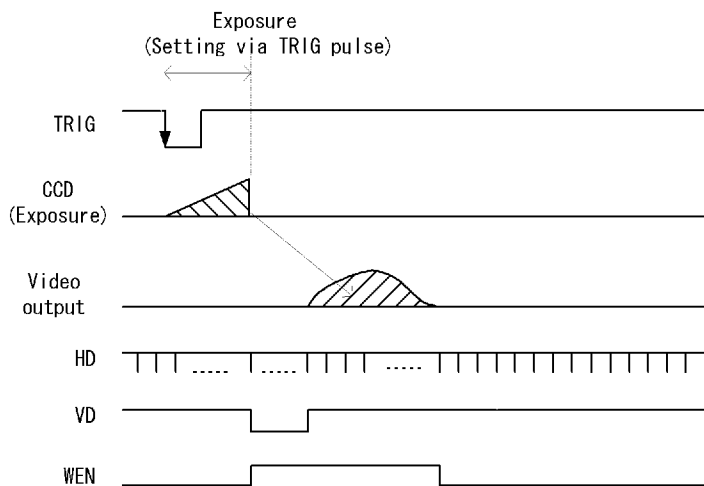

8-2 Analog output

(1) H rate

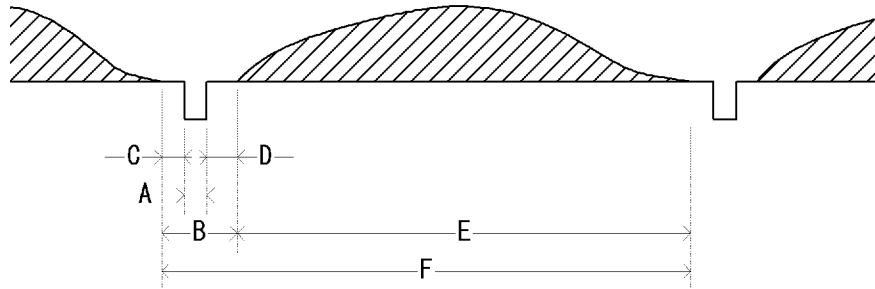

$$1\text{CLK} = 55.5\text{ns} (18\text{MHz})$$

$$\text{H-SYNC } A = 40\text{CLK} = 2.22\mu\text{s}$$

$$\text{HBL } B = 212\text{CLK} = 11.77\mu\text{s}$$

$$\text{Front porch } C = 40\text{CLK} = 2.22\mu\text{s}$$

$$\text{Back porch } D = 132\text{CLK} = 7.33\mu\text{s}$$

$$\text{DATA } E = 1636\text{CLK} = 90.9\mu\text{s}$$

$$\text{H rate } F = 1848\text{CLK} = 102.7\mu\text{s} = 9.74\text{kHz}$$

(2) V rate

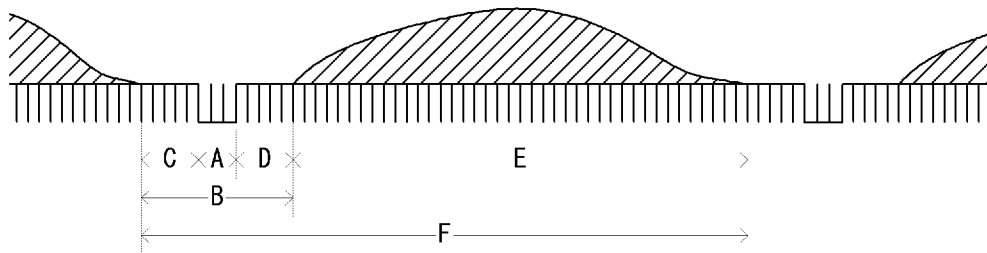

Normal read-out mode (Interlace 1-field)

$$A = 3H$$

$$B = 32H$$

$$C = 4H$$

$$D = 25H$$

$$E = 618H$$

$$F = 650H = 15\text{Hz}$$

High-speed draft mode

$$A = 3H$$

$$B = 16H$$

$$C = 3H$$

$$D = 10H$$

$$E = 309H$$

$$F = 325H = 30\text{Hz}$$

8-3. Digital output

EIA RS-644 (LVDS)

Driver output voltage: $\pm 350\text{mV}$ [Differential output] / 100Ω

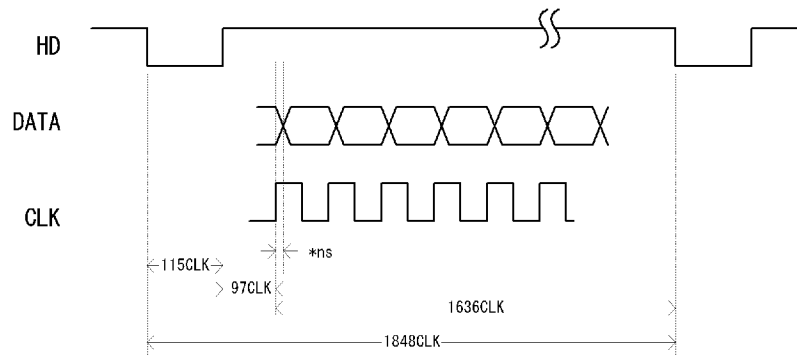

Total clock counts 1848CLK / 1H

DATA counts 1636CLK / 1H

CLK 55.5ns

*ns *=Delay

V rate phase: Same as one in analog timing-chart

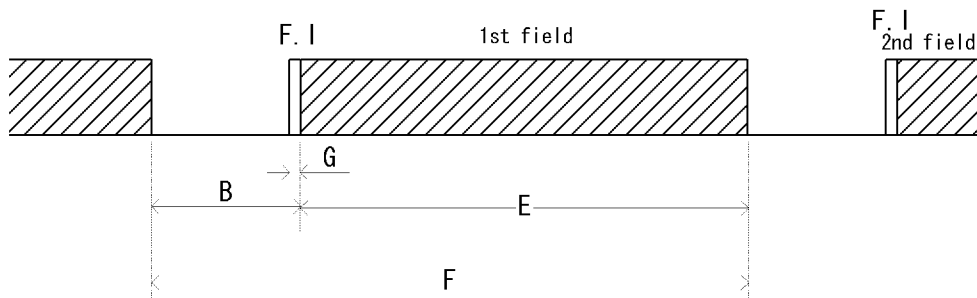

Digital output: Field ID signal superposed 1 line ahead of VS

FLD index pulse

G = 1H (Superposed on LSB)

1st FLD: H level output during data output (1636CLK)

2nd FLD: L level output during data output (1636CLK)

9. External-view drawing

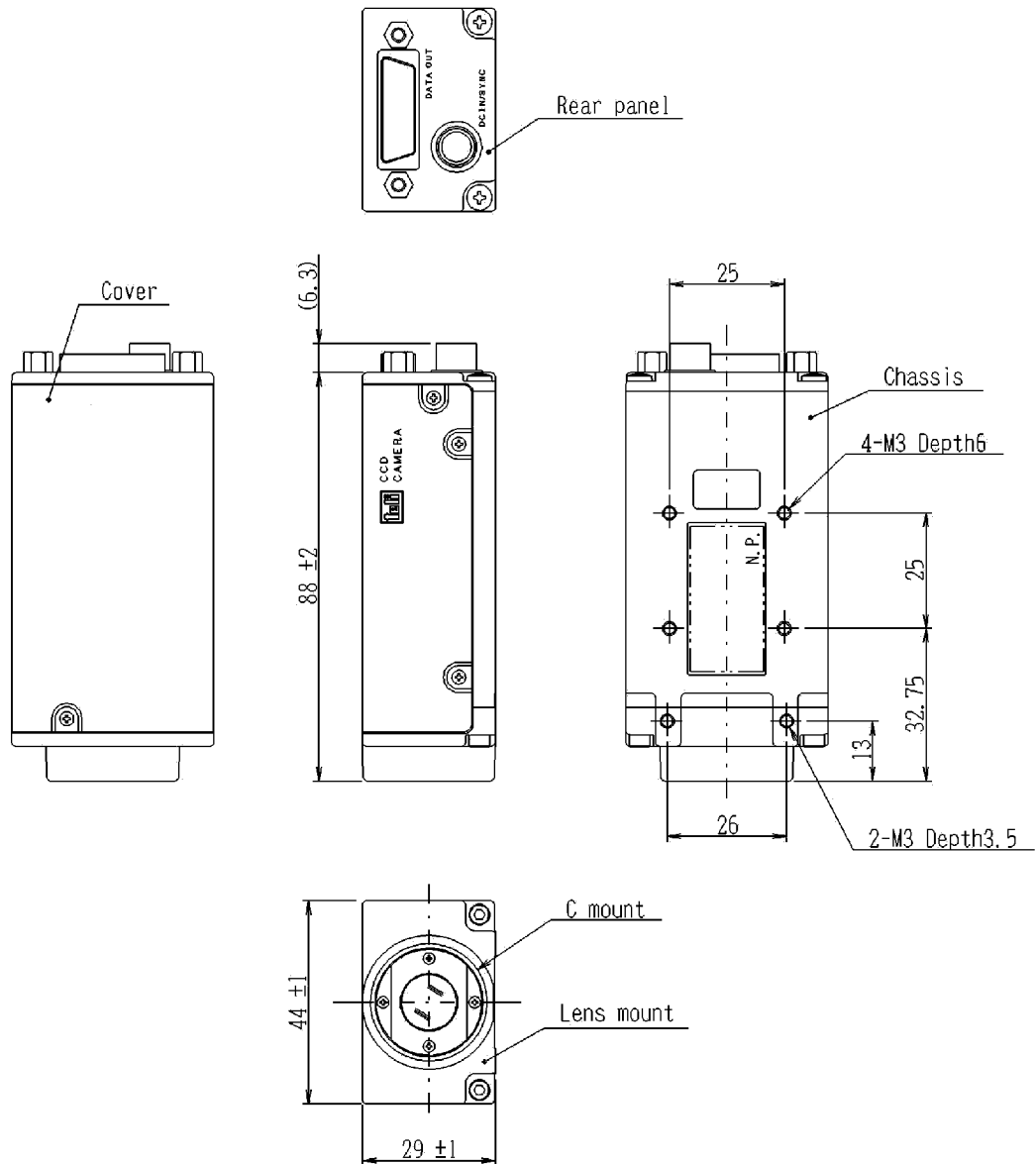

Design specification

Material

Lens mount : Zinc die cast
 Chassis & Rear panel : Aluminum die cast
 Cover : Aluminum alloy

Processing

Coating : Leather satin coating
 Coating color : Black