



CCD Monochrome Video Camera

Operation Manual

Model

CS8620Bi (EIA) CS8620BCi (CCIR)
 CS8630Bi (EIA) CS8630BCi (CCIR)
 CS8620BHi (EIA) CS8620BHCi (CCIR)

TOSHIBA TELI CORPORATION

BEFORE USE - GENERAL SAFETY INSTRUCTIONS

This instruction manual contains important information for the operator (user) and/or people around him/her to avoid personal injury, or property damage to him/her or people around him/her by using this product correctly. Prior to use, read this operation manual carefully to fully understand its instructions for correct use.

OWNER'S RECORD

Please fill in the blank below the model name and product serial number, which is found on bottom chassis of your device. Keep this number for your record.

Model Name _____

Serial No. _____

WARNINGS & CAUTIONS

[Definition of markings]

The meaning of each mark used in this instruction manual is given below.

	This mark warns the user that improper use, indicated with this mark, may cause death or severe personal injuries against the user or people around him/her.
	This mark warns the user that improper use, indicated with this mark, may cause personal injuries (*1) or material damages (*2) against the user or people around him/her.

Notes

- *1 : Personal injuries mean wounds, burns, electric shocks, and others for which the person injured need not to be hospitalized nor to be cared for the long term.
- *2 : Material damages mean any direct or consequential damages related to property or material loss.

	This mark indicates what the user SHOULD NOT DO . The details of things which the user should not do are described next to this mark.
	This mark indicates what the user MUST DO . The details of things which the user must do are described next to this mark.
	This mark indicates that the user must be alert against a possible DANGER . The details of the danger which the user must be aware of are described next to this mark.
	This mark indicates that the user are given a CAUTION against possible hazards. The details of the caution which the user must be aware of are described next to this mark.

Handling Precautions

	DANGER If any <u>overheating sign is observed, discontinue use immediately.</u> In the event that smoke, smell, or any other overheating sign is observed, turn its power switch OFF immediately, and remove its camera cable from camera connector. Do NOT try to continue to use your camera. To do so in spite of a clear sign of a malfunction invites a fire, an electric shock hazard, or any other serious damage. In such case, after confirming that there is no risk of a fire accident, contact us or our dealer/distributor through which you purchased this device for repair service. To avoid hazard, do NEVER attempt to repair it yourself.
	MUST If any <u>malfunctioning sign is observed, discontinue use immediately.</u> Do NOT try to use this device when it is obviously malfunctioning. (Example: No images on the monitor) In the event of a malfunction, turn its power switch OFF immediately, and remove its camera cable from camera connector. In such case, contact us or our dealer/distributor through which you purchased this device for repair service.
	MUST If any <u>liquid gets into the device, discontinue use immediately.</u> In the event that water, or any other type of liquid gets into the body, do NOT try to continue to use the device. To do so invites a fire or an electric shock hazard. In such case, turn its power switch OFF immediately, and then remove its camera cable from camera connector. After that, contact us or our dealer/distributor through which you purchased this device for repair service/technical advice.
	MUST <u>Connection/Disconnection only AFTER power OFF.</u> When you connect/disconnect camera connector, make sure to turn power SW OFF first. This camera is not designed for "hot-plugging". Do NEVER make connection/disconnection while power ON. Doing so might cause a breakdown.

	DANGER Use <u>manufacturer-recommended peripheral devices (option units) only.</u> Make sure to use option units specified in this operation manual only. When connected with any other non-guaranteed peripheral devices, your camera might fail to perform its full capacity. In the worst case, it might cause a fire or breakdown.
	MUST Do NOT <u>disassemble this device.</u> Do NOT attempt to pull apart, repair, or modify your camera yourself. To do so might lead to a fire or an electric shock accident. Contact us or the dealer/distributor from which you purchased the device for repair/modification.
	NEVER pull apart Do NOT <u>supply any power other than specified.</u> This device is designed to work only under specified voltage. Do NOT attempt to supply the device with power other than specified. Supplying the device with any unspecified power invites a fire or an electric shock hazard. (CS8600 series --- DC+12V)
	DON'T Do NOT <u>use the camera in a high-humidity environment.</u> Do NOT place your camera near a humidifier, or in other high-humidity environment. To do so might cause a fire or an electric shock accident.

Handling Precautions

	CAUTION If the camera is operated in the electromagnetic field, there may be cases where beat noises (vertical, horizontal, or oblique stripes) appear in the video output. In that case, take preventive measures on the electromagnetic-wave generating source so that your camera do not receive the interference by the electromagnetic-wave. Take extra precautions against electromagnetic-wave-interference if your camera is used with a servomotor, inverter, or other electromagnetic-wave-generating equipment.
	CAUTION Avoid giving a strong shock against the camera body. It might cause a breakdown or damage. If your camera is used in a system where its camera head is subjected to strong repetitive shocks, its camera head is possible to break down. If you intend to use your camera in such a situation, make sure to use an optional camera-connector -fixing-hardware to connect the connector-plug to the camera body.
	CAUTION When the camera is not in use, put a lens or a lens-cap onto the camera head so that the image pickup plane of CCD is protected from dust, foreign object, or any other flaw-causing object. If the glass plane (image pickup plane) gets dirty, clean it with a cotton swab. When it needs to be cleaned with a cleaner, be sure NOT to use any organic solvent other than ethyl alcohol. As a countermeasure against condensation, when the camera is moved from a warm condition/environment to a cold one, take appropriate precautions to prevent condensation from forming on the camera.
	CAUTION Do not pull strongly the camera cable/camera-head nor swing it. The stress from pulling or swinging may cause damage in the coating of the cable, or breaks in the inside wires.
	CAUTION Avoid short-circuiting signal output. Otherwise, it may cause a malfunction.
	CAUTION Do NEVER expose its camera head to any intensive light (such as direct sunlight). Otherwise, its inner image pickup device might get damaged.

This equipment has been tested and found to comply with the limits for a class A digital device, pursuant to Part 15 of the FCC Rules. These limits are designed to provide reasonable protection against harmful interference when the equipment is operated in a commercial environment. This equipment generates, uses, can radiate radio frequency energy and, if not installed and used in accordance with the instruction manual, may cause harmful interference to radio communications. Operation of this equipment in a residential area is likely to cause harmful interference in which case the user will be require to correct the interference at his own expense.

This device complies with Part 15 of the FCC rules. Operation is subject to the following two conditions: (1) This device may not cause harmful interference, and (2) This device accept any interference received, including interference that may cause undesired operation.

RESTRICTION FOR USE

In the case where a malfunction of this camera (e.g. video output cut-off) can be expected to lead to a significant accident, avoid using this device for such system build-in use.

DISCLAIMER (LIMITED WARRANTY)

We assume no responsibility and shall be held harmless for damage or loss incurred by the user in the following cases.

- In the case where damage or loss is caused by fire, earthquake, or other acts of Gods, acts by a third party, misuse by the user deliberately or erroneously, or use under extreme operating conditions.
- In the case where any indirect, additional, consequential damages (e.g. loss of expected interest, suspension of business activities) are incurred as results of a malfunction or non-functioning of this device, we shall be exempted from assuming responsibility for such damages.
- In the case where damage or loss is caused by incorrect use which is not in line with the instructions given in this operation manual.
- In the case where damage or loss is caused by a malfunction resulting from bad connection with other equipment.
- In the case where damage or loss is caused by repair or modification done by the user.

PRODUCT DESCRIPTION

Model CS86xxBi is a miniature camera series featuring its ultra-small light-weight body. The CS86xxBi camera series is designed mainly for factory automation, machine vision, and image measurement application.

FEATURES

- High resolution**
The 380,000 pixel CCD realizes the horizontal resolution of 570TV lines.
High-density images with minimum moire-fringes & beatings are obtained. (CCIR: 440,000 pixels, 560TV lines)
- Ultra-compact & light-weight body**
The camera features its ultra-small light-weight body. Its super-small body will free you from much of your space restriction problem. The camera is driven by DC12V.
- Electronic shutter**
The built-in electronic shutter allows this camera to capture a fast-moving object clearly and sharply.
- AGC (Automatic Gain Control)**
This series is equipped with AGC function. With the AGC, the camera obtains optimal images constantly even when the amount of incoming light fluctuates.
- Restart/Reset**
When the restart/reset function set ON, the camera captures images at any timing given by R.R. pulse input (VD input).
Remark : CS8620BHi, CS8620BHCi are possible for a restart/reset operation only at the field integration mode.
- SS (Special shutter) & RTS (Random trigger shutter)**
This camera is fitted with special shutter and random trigger shutter function, which allows the camera to capture images cued by external trigger input.
- Near-infrared region sensitivity (Model ----H type only)**
The CCD integrated in the model CS8620BHi and CS8620BHCi has a near-infrared-region sensitivity. These models capture clear images even under near-IR shooting condition.
- RoHS compliant**

CS8600Bi Series Spec Lookup Table

Model name	Image size	TV format	Near IR	SS / RTS	R.R.
CS8620Bi	1/2 type	EIA	×	○	○
CS8620BHi	1/2 type	EIA	○	○	○
CS8630Bi	1/3 type	EIA	×	○	○
CS8620BCi	1/2 type	CCIR	×	○	○
CS8620BHCi	1/2 type	CCIR	○	○	○
CS8630BCi	1/3 type	CCIR	×	○	○

CONFIGURATION

- Camera body 1
- Accessory Manual 1

CONNECTION / MODE / REAR-PANEL SWITCH

- Connector Pin Assignment
Compatible plug: HR10A-10P-12S
(Manufactured by HIROSE ELEC.)

Pin No.	External sync.			Internal sync.
	HD VD	VS/SYNC	R.R.	
1	GND	GND	GND	GND
2	+12V	+12V	+12V	+12V
3	GND	GND	GND	GND
4	VIDEO OUT	VIDEO OUT	VIDEO OUT	VIDEO OUT
5	GND	GND	GND	GND
6	HD IN	----	HD IN	HD OUT*
7	VD IN	VS/SYNC IN	R.R. IN	VD OUT*
8	GND	GND	GND	GND
9	CLOCK OUT	CLOCK OUT	CLOCK OUT	CLOCK OUT
10	WEN OUT	WEN OUT	----	WEN OUT
11	TRIG IN	TRIG IN	TRIG IN	TRIG IN
12	GND	GND	GND	GND

* HD VD output is available via inner SW selection under internal sync operation.

Connection Example

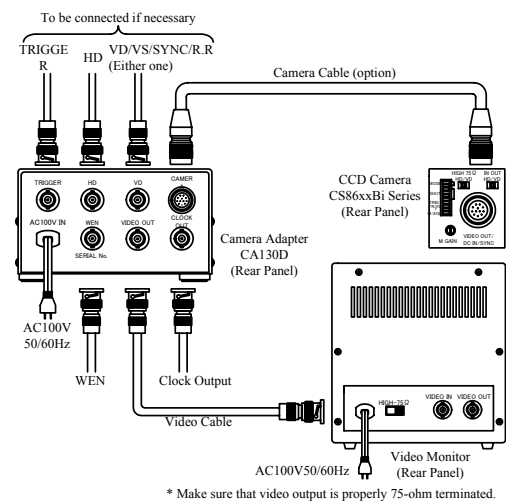

Rear SW, Potentiometer, Connector

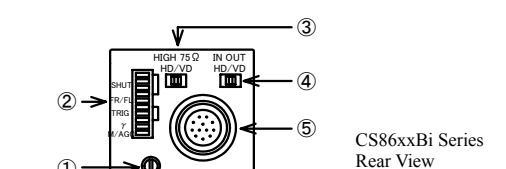

- Gain adjustment potentiometer**
This manual gain adjuster is enabled under Manual Gain Control setting (Gain selection SW: MGC). Turned clockwise, video amplification gain increases.
- Mode selection SW**
This is the camera mode selection switch.
- 75-ohm termination ON/OFF SW**
This SW switches external-sync input terminal 75-ohm termination ON/OFF. When set in right side, the termination is 75-ohm. When set in left, it is 10k-ohm. The initial factory setting is in OFF position.
- HD VD IN/OUT selection SW**
This is the HD VD sync-signal IN/OUT selection switch. The status is HD VD IN when set in left side, HD VD OUT when in right. The initial setting is EXT.

DC IN/SYNC

This connector is for DC power input, external sync signal input, and video output, to be connected with a power supply, sync-signal generator, and video monitor.

DIP SW

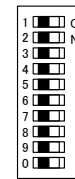

Using the rear-panel DIP switch, you can make various mode setting. Each numbered switch is OFF in LEFT position, and ON in RIGHT position.

[Shutter-speed Setting]		X : Don't care		
No.	SHUTTER OFF	1/125	1/250	1/500
1	X	X	X	X
2	X	X	X	X
3	OFF	ON	OFF	ON
4	OFF	OFF	ON	ON
5	OFF	OFF	OFF	OFF
6	OFF	OFF	OFF	OFF
7	X	X	X	X
8	X	X	X	X
9	X	X	X	X
0	X	X	X	X
No.	1/1,000	1/2,000	1/4,000	1/10,000
1	X	X	X	X
2	X	X	X	X
3	OFF	ON	OFF	ON
4	OFF	OFF	ON	ON
5	ON	ON	ON	ON
6	OFF	OFF	OFF	OFF
7	X	X	X	X
8	X	X	X	X
9	X	X	X	X
0	X	X	X	X
No.	Flicker-less	1FLD	2FLD	4FLD
1	X	X	X	X
2	X	X	X	X
3	OFF	ON	OFF	ON
4	OFF	OFF	ON	ON
5	ON	ON	ON	ON
6	OFF	OFF	OFF	OFF
7	X	X	X	X
8	X	X	X	X
9	X	X	X	X
0	X	X	X	X
No.	6FLD	8FLD	10FLD	Pulse-width
1	X	X	X	X
2	X	X	X	X
3	OFF	ON	OFF	ON
4	OFF	OFF	ON	ON
5	ON	ON	ON	ON
6	ON	ON	ON	ON
7	X	X	X	X
8	X	X	X	X
9	X	X	X	X
0	X	X	X	X

[Mode Setting]

No.	G A I N		TRIGGER Polarity	
	MGC	AGC	POSI	NEGA
1	X	X	X	X
2	X	X	X	X
3	X	X	X	X
4	X	X	X	X
5	X	X	X	X
6	X	X	X	X
7	X	X	OFF	ON
8	X	X	X	X
9	X	X	X	X
0	OFF	ON	X	X
No.	Integration Mode		Gamma Correction	
	Frame	Field	1.0	0.45
1	X	X	X	X
2	X	X	X	X
3	X	X	X	X
4	X	X	X	X
5	X	X	X	X
6	X	X	X	X
7	X	X	X	X
8	OFF	ON	X	X
9	X	X	OFF	ON
0	X	X	X	X

[Restart Reset / Special Shutter]

No.	Normal	Restart Reset	Special Shutter
1	OFF	ON	ON
2	OFF	ON	ON
3	OFF	ON	ON
4	OFF	ON	ON
5	OFF	ON	ON
6	OFF	ON	ON
7	X	X	X
8	X	X	X
9	X	X	X
0	X	X	X

[Random trigger shutter]

No.	Normal	Mode 1,2	Mode 3,4
1	OFF	OFF	OFF
2	OFF	OFF	ON
3	OFF	X	X
4	OFF	X	X
5	OFF	X	X
6	OFF	X	X
7	X	X	X
8	X	X	X
9	X	X	X
0	X	X	X
No.		Mode 5,6	Mode 7,8
1		OFF	ON
2		OFF	OFF
3		X	X
4		X	X
5		X	X
6		X	X
7		X	X
8		X	X
9		X	X
0		X	X

OPERATION

- Connect each system component as illustrated in Section 4 above.
- Turn the power switch of the video monitor ON.
- Feed power to the camera.
- Confirm that images appear on the video monitor. Adjust the lens aperture so that the optimal illumination is obtained.
- While monitoring the images on the video monitor, adjust the lens-focus so that the sharpest images are obtained.
- Adjust sensitivity. The factory setting is in MGC (Manual Gain Control). AGC (Automatic Gain Control) mode is also available. The selection is made via DIP SW selection on the rear side. Under the MGC mode, the rear-panel M GAIN potentiometer is enabled for manual gain adjustment by a user.
- Select gamma factor. The factory setting is 1.0. The selection between 1.0 and 0.45 is made via the rear DIP SW selection.
- Select the electronic shutter ON/OFF. The factory setting is in OFF position. To set E-shutter ON, use the rear-panel DIP SW.
- Select integration mode. The selection between the frame/field integration is made via the rear DIP SW selection. The initial factory setting is the frame integration.
- Set restart/reset, special shutter, or random trigger shutter mode as necessary. The factory setting is all in OFF position. Each function is set ON/OFF via the rear DIP SW selection.
- If you need HD VD output, use the rear SW under internal sync operation.
- For connection with an image processor and other peripheral devices, this camera is provided with CLK OUT (Clock output function).

SPECIFICATION

- TV system (EIA) Based on EIA standard
(CCIR) Based on CCIR standard
- Image sensor
• Total pixel counts (EIA) 811(H)×508(V)
(CCIR) 795(H)×596(V)
• Active pixel counts (EIA) 768(H)×494(V)
(CCIR) 752(H)×582(V)
• Video output pixel counts (EIA) 756(H)×485(V)
(CCIR) 742(H)×575(V)
• Cell size (CS8620Bi/BHi) 8.4×9.8 μm
(CS8620BCi/BHCi) 8.6×8.3 μm
(CS8630Bi) 6.35×7.4 μm
(CS8630BCi) 6.5×6.25 μm
• Scanning area (CS8620Bi/BCi) 6.5×4.85mm
(/BHi/BHCi) (type-1/2)
(CS8630Bi/BCi) 4.8×3.6mm
(type-1/3)
• H drive frequency (Internal sync) (EIA) 14.31818MHz ±100ppm
(CCIR) 14.18750MHz ±100ppm
- Scanning lines (EIA) 525 lines
(CCIR) 625 lines
- Scanning format 2 : 1 interlace
- Sync System Internal/External (automatic change over)
- Scanning frequencies (internal synchronization mode) Horizontal drive (H) (EIA) 15.734kHz ±100ppm
(CCIR) 15.625kHz ±100ppm
Vertical drive (V) (EIA) 59.94Hz ±100ppm
(CCIR) 50.0Hz ±100ppm
- Aspect ratio 4:3
- Sensitivity
• Standard (GAIN:MGC, γ=1.0) (CS8620Bi/BCi, CS8630Bi/BCi) 200 lx ·F5.6 (3100K)
(CS8620BHi/BHCi) 400 lx ·F11 (3100K)
• Minimum (GAIN:MAX, γ=0.45) (CS8620Bi/BCi) 0.2 lx ·F1.4
(CS8630Bi/BCi) 0.2 lx ·F1.4
(CS8620BHi/BHCi) 0.1 lx ·F1.4
- Video output VS:1.0V(p-p) /75 Ω
- Resolution VS (Video + SYNC) Horizontal (EIA) 570 TV lines
(CCIR) 560 TV lines
Vertical (EIA) 485 lines (350 TV lines)
(CCIR) 575 lines (410 TV lines)
- S/N 60dB(p-p)/rms (typical) (GAIN:MGC, γ=1.0)
- Input signal
① External sync pulses
• Pulse level HD, VD, SYNC:2~6V(p-p)
VS:1.0(SYNC0.3)V(p-p)
• Input impedance 75 Ω / High Switch-able by the panel SW (Initial factory setting: High)
• Scanning system 2 : 1 interlace
• Polarity Negative
• Pulse width HD:6.4±3 μs
VD:150~800 μs
• Frequency Horizontal (fH) (EIA) fH=15.734kHz ±2%
(CCIR) fH=15.625kHz ±2%
Vertical (fV) (EIA) fV=2fH/525
(CCIR) fV=2fH/625
• Scanning lines (EIA) 525 lines
(CCIR) 625 lines
• Phase different The difference in phase between the falling edge of VD and that of HD is shown in the figure below.
1st FIELD for EIA 2nd FIELD for EIA
2nd FIELD for CCIR 1st FIELD for CCIR
VD
HD
t1
t2
t1=0±5 μs t2=(1/2) fH±5 μs
② Shutter trigger (TRG)
• Pulse level VL=0~0.5V VH=2~5V

- Input impedance High impedance
 - Polarity Positive
 - Pulse width 2 μs~1/4s
- Output signal
① HD/VD pulses Under internal sync operation, output available by the panel SW selection (Initial factory setting: IN) HD: 4.5±0.5V(p-p)
VD: 5.0±0.5V(p-p)
• Output level (high impedance) HD: 4.5±0.5V(p-p)
VD: 5.0±0.5V(p-p)
• Scanning system 2 : 1 interlace
• Polarity Negative
• Pulse width (EIA) HD: 6.36±1 μs, VD: 572±10 μs
(CCIR) HD: 6.41±1 μs, VD: 480±10 μs
• Frequency Horizontal (fH) (EIA) fH=15.734kHz ±100ppm
(CCIR) fH=15.625kHz ±100ppm
Vertical (fV) (EIA) fV=2fH/525
(CCIR) fV=2fH/625
• Scanning lines (EIA) 525 lines
(CCIR) 625 lines
② Clock pulse
• Output level 2.0±0.3V(p-p) (high impedance)
• Frequency (Under internal synchronization) (EIA) 14.31818 MHz±100ppm
(CCIR) 14.18750 MHz±100ppm
③ WEN Under random trigger shutter operation, WEN is output during the period starting from the VIDEO OUT START VD falling edge through the VIDEO OUT END VD falling edge.
• Polarity Positive
• Diagram The circuit is shown in the figure below.

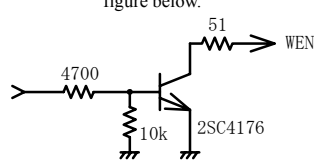

- Sensitivity setting Mode selection via panel SW (Initial factory setting: MGC) AGC(Automatic Gain Control) MGC (Manual Gain Control)
- MGC Manual sensitivity adjustment available
- Gamma 1.0 / 0.45 selectable via rear panel DIP switch (Initial factory setting: 1.0)
- White clip Clip-level: 820±40mV(p-p) (Excluding SYNC)
- Electronic shutter Normal shutter The following shutter speed setup is possible by rear panel DIP switch selection. Normal, 1/125, 1/250, 1/500, 1/1000, 1/2000, 1/4000, 1/10000s, and Flicker-less (Initial Factory setting: Normal)
Slow-speed shutter 1FLD, 2FLD, 4FLD, 6FLD, 8FLD, and 10FLD

(19) Random trigger shutter RTS Mode selection available

Setting	Internal sync	SYNC
1 Shutter-speed Switch Setting	Internal sync	SYNC Non-reset
2 Shutter-speed TRIG Pulse-width Setting	Internal sync	SYNC Non-reset
3 Shutter-speed Switch Setting	Internal sync	SYNC Reset
4 Shutter-speed TRIG Pulse-width Setting	Internal sync	SYNC Reset
5 Shutter-speed Switch Setting	HD / VD IN (*1)	SYNC Non-reset
6 Shutter-speed TRIG Pulse-width Setting	HD / VD IN (*1)	SYNC Non-reset
7 Shutter-speed Switch Setting	HD / VD IN (*2)	SYNC Non-reset
8 Shutter-speed TRIG Pulse-width Setting	HD / VD IN (*2)	SYNC Non-reset

*1: Consecutive HD / Consecutive VD IN

*2: Consecutive HD / Single VD IN

- Special shutter User-defined shutter-timing and shutter-speed cued and timed by shutter trigger and restart / reset pulse input ON / OFF selectable via rear panel DIP SW (Initial factory setting: OFF)
- CCD integration mode Field / Frame storage(integration) Switch-able by rear panel DIP Switch Selection (Initial factory setting: frame integration)
- Restart/Reset Restart / Reset function available via rear panel DIP-SW selection (Initial factory setting: OFF)
Remark : CS8620BHi, CS8620BHCi are possible for a restart/reset operation only at the field integration mode.
- Power source DC12V±10%[Ripple level : Less than 10mV(p-p)] approx. 1.3W
- Ambient condition
• Performance assurance Temperature 0°C~40°C
Humidity 20~80% (No condensing)
• Operation assurance Temperature -10°C~50°C
Humidity 20~80% (No condensing)
• Storage Temperature -20°C~60°C
Humidity 20~95% (No condensing)
- Lens mount C-mount
- Flange back 17.526mm
- Dimensions 29(W)×29(H)×31(D)mm (Excluding protruding part)
- Mass Approx. 42g
- Option unit
• Power adapter CA130D (AC100V)
• Power / Video connector (Maker : Hirose denki) HR10A-10P-12S
• Camera cable CPSC2000 (2m)
• Camera cable
• Tripod adapter
• IR cut filter

DRAWINGS

CS8620Bi series

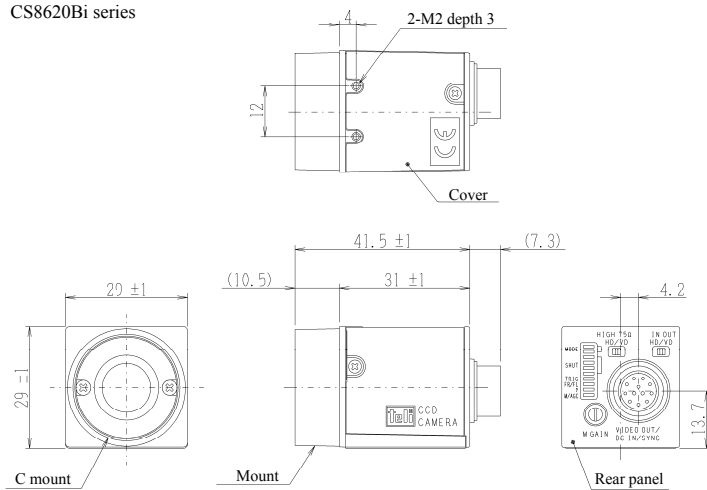

CS8630Bi series

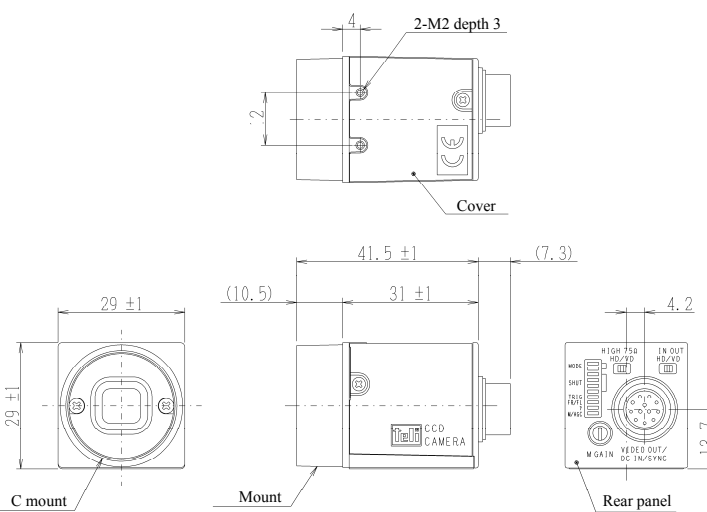

CS8620BHi

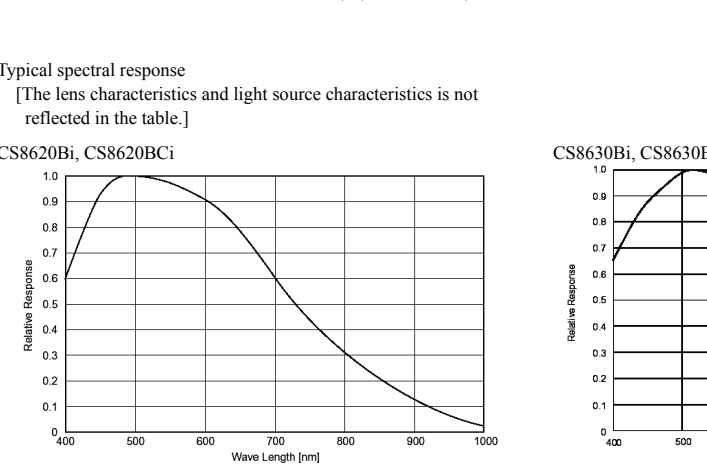

CS8620BHCi

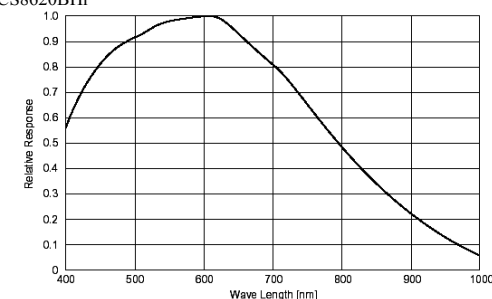

CS8630Bi, CS8630BCi

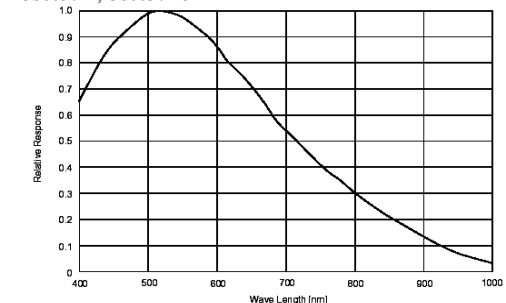

CS8620BHCi

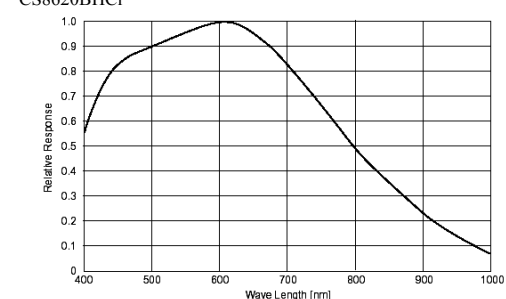

HOW TO FIX CAMERA

- Use tripod
If you use tripod, use camera mounting kit (optional) and fix camera.

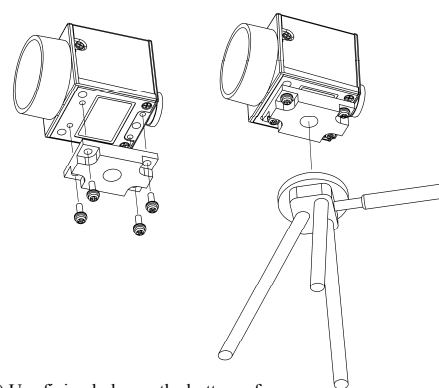

- Use fixing holes on the bottom of camera
If you use fixing holes on the bottom of camera, Please use screw (M2 and M3). Please use screw length less than 3mm.

CAUTION

If the screw is long, it touches with printed circuit board, and it causes some trouble and accident.

Following information is only for EU-member states:

The use of the symbol indicates that this product may not be treated as household waste. By ensuring this product is disposed of correctly, you will help prevent potential negative consequences for the environment and human health, which could otherwise be caused by inappropriate waste handling of this product. For more detailed information about the take-back and recycling of this product, please contact your supplier where you purchased the product.



"This symbol is applicable for EU member states only"