

Rolling shutter CMOS Image Sensor

# CMOS Camera BU Series

**BU2006MG**  
**BU2006MCF**

## Specifications

# Toshiba Teli Corporation

Information contained in this document is subject to change without prior notice.  
Standard name might be trade mark of each company.

## Contents

RESTRICTION FOR USE .....	1
CASES FOR INDEMNITY (LIMITED WARRANTY) .....	2
USAGE PRECAUTIONS .....	3
1. Overview .....	6
2. Features .....	6
3. Configuration.....	8
4. Optional part.....	8
5. Functions .....	9
6. Specifications.....	19
7. Timing chart.....	33
8. Warranty rules.....	35
9. Repair .....	36
10. Outline Drawing.....	37

## RESTRICTION FOR USE

- Should the equipment be used in the following conditions or environments, give consideration to safety measures and inform us of such usage:
  - (1) Use of the equipment in the conditions or environment contrary to those specified, or use outdoors.
  - (2) Use of the equipment in applications expected to cause potential hazard to people or property, which require special safety measures to be adopted.
- This product can be used under diverse operating conditions. Determination of applicability of equipment or devices concerned shall be determined after analysis or testing as necessary by the designer of such equipment or devices, or personnel related to the specifications. Such designer or personnel shall assure the performance and safety of the equipment or devices.
- This product is not designed or manufactured to be used for control of equipment directly concerned with human life (\*1) or equipment relating to maintenance of public services/functions involving factors of safety (\*2). Therefore, the product shall not be used for such applications.
  - (\*1): Equipment directly concerned with human life refers to.
    - Medical equipment such as life-support systems, equipment for operating theaters.
    - Exhaust control equipment for exhaust gases such as toxic fumes or smoke.
    - Equipment mandatory to be installed by various laws and regulations such as the Fire Act or Building Standard Law
    - Equipment related to the above
  - (\*2): Equipment relating to maintenance of public services/functions involving factors of safety refers to.
    - Traffic control systems for air transportation, railways, roads, or marine transportation
    - Equipment for nuclear power generation
    - Equipment related to the above

## CASES FOR INDEMNITY (LIMITED WARRANTY)

We shall be exempted from taking responsibility and held harmless for damage or losses incurred by the user in the following cases.

- Natural disasters, such as an earthquake and thunder, fire or any other act of God; acts by third parties; misuse by the user, whether intentional or accidental; use under extreme operating conditions.
- In the case of indirect, additional, consequential damages (loss of business interests, suspension of business activities) are incurred as result of malfunction or non-function of the equipment, we shall be exempted from responsibility for such damages.
- In the case damage or losses are caused by failure to observe the information contained in the instructions in this instruction manual and specifications.
- In the case damage or losses are caused by use contrary to the instructions in this instruction manual and specifications.
- In the case damage or losses are caused by malfunction or other problems resulting from use of equipment or software that is not specified.
- In the case damage or losses are caused by repair or modification conducted by the customer or any unauthorized third party (such as an unauthorized service representative).
- Expenses we bear on this product shall be limited to the individual price of the product.
- The item that is not described in specifications of this product is off the subject of the guarantee.
- The attachment mistake of a cable.

## USAGE PRECAUTIONS

### ● Life expectancy of CMOS sensors

Unlike other products, the CMOS sensor used in this product is not a CMOS sensor for industrial equipment. Please note that the life of the CMOS sensor may be shortened depending on the operating conditions of the camera (ambient temperature, heat radiation conditions, etc.).

### ● Handle carefully

Do not drop the equipment or allow it to be subject to strong impact or vibration, as such action may cause malfunctions. Further, do not damage the connection cable, since this may cause wire breakage.

### ● Environmental operating conditions

Do not use the product in locations where the ambient temperature or humidity exceeds the specifications.

Otherwise, image quality may be degraded or internal components may be adversely affected. In particular, do not use the product in areas exposed to direct sunlight.

### ● Combination of C-mount lens

Depending on the lens you use, the performance of the camera may not be brought out fully due to the deterioration in resolution and brightness in the peripheral area, occurrence of a ghost, aberration and others. When you check the combination between the lens and camera, be sure to use the lens you actually use.

When installing a lens in the camera, make sure carefully that it is not tilted.

In addition, use a mounting screw free from defects and dirt. Otherwise, the camera may be unable to be removed.

As for the C-mount lens used combining this product, the projection distance from bottom of the screw should use 8mm or less.

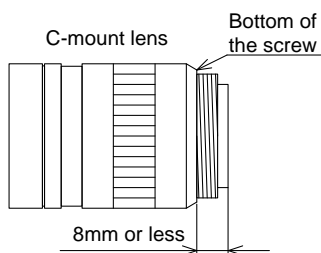

- **Mounting to a pedestal**

When mounting this product to a pedestal, make sure carefully that the lens doesn't touch with the pedestal.

- **Do not expose the camera's image-pickup-plane to sunlight or other intense light directly.**

Its inner CMOS sensor might be damaged.

- **Occurrence of moiré**

If you shoot thin stripe patterns, moiré patterns (interference fringes) may appear. This is not a malfunction.

- **Occurrence of noise on the screen**

If an intense magnetic or electromagnetic field is generated near the camera or connection cable, noise may be generated on the screen. If this occurs, move the camera or the cable.

## USAGE PRECAUTIONS

- **Handling of the protective cap**

If the camera is not in use, attach the lens cap to the camera to protect the image pickup surface.

- **If the equipment is not to be used for a long duration**

Turn off power to the camera for safety.

- **Maintenance**

Turn off power to the equipment and wipe it with a dry cloth.

If it becomes severely contaminated, gently wipe the affected areas with a soft cloth dampened with diluted neutral detergent. Never use alcohol, benzene, thinner, or other chemicals because such chemicals may damage or discolor the paint and indications.

If the image pickup surface becomes dusty, contaminated, or scratched, consult your sales representative.

- **Disposal**

When disposing of the camera, it may be necessary to disassemble it into separate parts, in accordance with the laws and regulations of your country and/or municipality concerning environmental contamination.

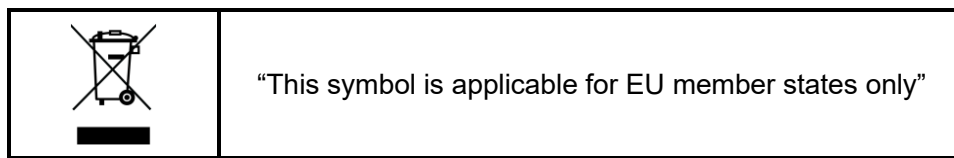

### [Phenomena specific to CMOS sensor]

- **Defective pixels**

A CMOS image sensor is composed of photo sensor pixels in a square grid array. Due to the characteristics of CMOS image sensors, over- or under-driving of the pixels results in temporary white or black areas (as if these are noises) appearing on the screen. This phenomenon, which is not a defect is exacerbated under higher temperatures and long exposure time.

- **Image shading**

The brightness of the upper part of the screen may be different from that of the lower part. Note that this is a characteristic of a CMOS image sensor and is not a fault.

## 1. Overview

BU2006M series is an integrated-(one-body)-type camera that adopts a rolling shutter CMOS sensor. Suffix [C] or [CF] are attached to the color models. For video output and camera control, the USB 3.1 Gen1 (USB3.0) interface standard is adopted for high transfer rate, and it is easy to integrate into industrial equipment.

## 2. Features

### 2.1 High frame rate

Supporting high frame rate, 19fps at 20 Mega pixels.

### 2.2 Global Reset

In the random shutter mode, this camera operates by the Global Reset, which starts an imaging operation in whole lines at same time. Together with the function and strobes, it is possible to get an imaging result similar to the Global Shutter.

### 2.3 USB 3.1 Gen1 (USB3.0) interface

Video output and camera control are performed via the USB 3.1 Gen1 (USB3.0, after here USB3.1 Gen1) standard interface. Data transfer is up to 5Gbps (Maximum) that enables to output uncompressed video data at high frame rate.

### 2.4 USB3 Vision

This product is based on USB3 Vision Ver.1.0.

### 2.5 GenICam Ver.2.4, Ver.3.0 conformity

This product is based on GenICam (Generic Interface for Cameras) Ver.2.4 and Ver.3.0.

### 2.6 IIDC2 Digital Camera Control Specification Ver.1.1.0

This product is based on IIDC2 Digital Camera Control Specification Ver.1.1.0.

### 2.7 e-CON Connector adoption

The e-CON connector adoption enables to assemble the cable easily without using special tools.



## **2.8 Random Trigger Shutter**

The Random Trigger Shutter function provides images in any timing by input of an external trigger signal. Trigger control from PC is available as well.

## **2.9 Scalable**

Selectable video output area. This mode achieves higher frame rate by reducing vertical output area. And reduces occupied data rate of USB bus by reducing horizontal output area.

## **2.10 Color processing**

Color models have built in color processing. There are RGB, BGR, YUV 4:2:2, YUV 4:1:1, Bayer and Mono output modes.

## **2.11 IR –cut filter**

Build-in IR-cut filter models are optional for color models.

Suffix [F] is attached to the model name of built-in IR-cut filter model. (e.g. BU2006MCF)

\* Suffix [F] is not shown in the common part of specifications.

## **2.12 Compact and lightweight**

This camera is compact and lightweight; it is easy to integrate into industrial equipment.

## **2.13 EU RoHS & Chinese RoHS**

### 3. Configuration

(1) Camera body

\* No application software and manuals are attached to this camera.

Software development kit "TeliCamSDK" is provided free of charge.

<https://www.toshiba-teli.co.jp/en/products/industrial-camera/software-telicamsdk.htm>

Windows version can downloaded from our website.

<https://www.toshiba-teli.co.jp/cgi/ss/en/service.cgi>

For the Linux version, please contact our sales representative.

<https://www.toshiba-teli.co.jp/en/contact/products.htm>

### 4. Optional part

- Camera mounting kit                      Model name: CPTBU, CPTBUBG

\* Contact your dealer / distributor for details of option units.

## 5. Functions

### 5.1 Gain

Manual gain and automatic gain control (AGC) settings are provided. Gain is adjustable from 0 to +24dB.

#### 5.1.1 Manual

The camera gain can be set manually.

#### 5.1.2 AGC

The camera gain is automatically adjusted to suit subject brightness.

#### **Notes on gain setting:**

Setting the gain value too high increases noises. When you adjust the brightness of the image, I ask you to have final image quality checked with your environment.

### 5.2 Black Level

Black level is adjustable from -25% to +25% as white saturation level is 100%.

### 5.3 Gamma

Gamma correction curve is adjustable from 0.45 to 1.

### 5.4 LUT (Look up Table)

Arbitrary curve and binarization are possible by using 12 bit input and 12 bit output LUT.

### 5.5 Exposure Time

Manual exposure time and automatic exposure time control (AE) are available

#### 5.5.1 Manual

Exposure time is adjustable by micro-second unit.

#### 5.5.2 AE

The exposure time is adjusted automatically to suit subject brightness.

This mode can also operate with AGC (Automatic Gain Control) to automatically adjust fluctuations in subject brightness across a wide range (ALC operation).

### 5.6 White balance

Color models have two white balance modes, manual white balance (MWB) and one-push auto white balance (OPWB). Select the mode to suit the subject and purpose.

#### 5.6.1 MWB

R/B gain can be set independently.

#### 5.6.2 OPWB

When OPWB is executed, the camera adjusts R/B gain automatically.

### 5.7 Masking correction

Color models have RGB 3x3 matrixes correction.

### 5.8 Hue

Color models have hue control.

### 5.9 Saturation

Color models have saturation control.

### 5.10 BayerProcessingMode

Color models can set up ProcessingMode at the time of Bayer output.

The function which becomes effective by setup of BayerProcessingMode is as follows.

Functions	Full	Partial	Raw
Gain	✓	✓	✓
BlackLevel	✓	✓	-
Gamma	✓	✓	-
Hue	✓	-	-
Saturation	✓	-	-
BalanceRatio	✓	✓	-
ColorCorrectionMatrix	✓	-	-
LUTControl	✓	✓	-
DPCControl	✓	✓	-

### 5.11 Chunk

It is possible to integrate some sort of information about each image with video data.

## 5.12 Random Trigger Shutter

An image is captured at the desired timing using trigger signal input. External trigger signal from trigger input connector and software trigger from control command via USB 3.1 Gen1 interface are available (Edge mode / Bulk mode). Trigger polarity is selectable (High active / Low active).

Note that Random Trigger Shutter will cause a delay between trigger signal and start of exposure. See 7. Timing Chart for detail. In random shutter mode, the camera operates with global reset. Operates with rolling shutter during binning.

### - Edge mode: TriggerSequence0

Exposure of all the lines is simultaneously started in the timing of a trigger input.

The exposure time of first line is the manual set value of the electronic shutter.

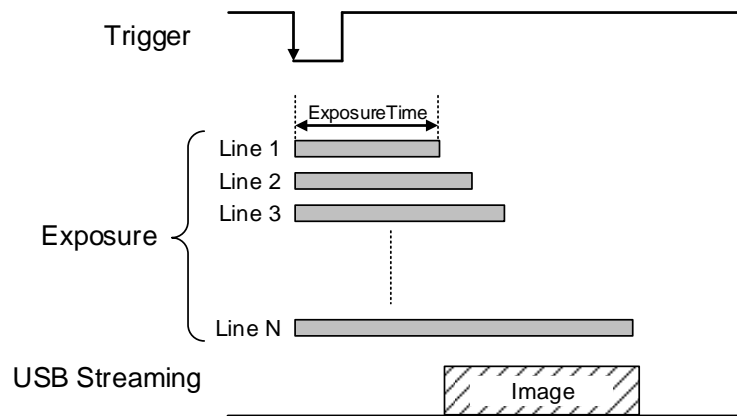

### - Bulk mode (FrameBurstTrigger): TriggerSequence6

Camera exposes and transfers multiple frames by a single trigger.

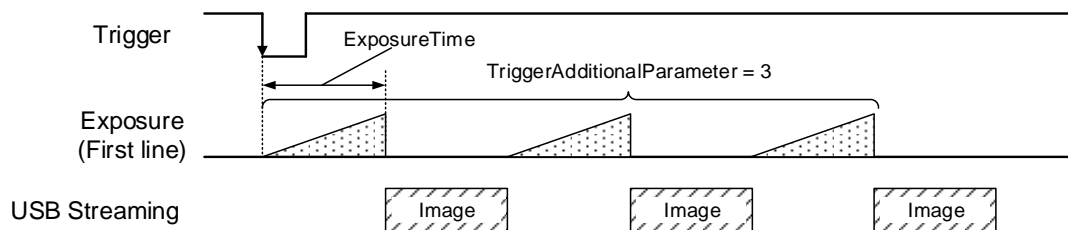

#### Notes on Random Trigger Shutter :

- In the period when FrameTriggerWait signal is inactive, user must not input external trigger signal to this camera.
- When the interval of the input trigger signal is extremely short, or when the trigger signal is noisy, there is a possibility of causing the malfunction. In this case, please input a proper trigger signal.

### **Rolling Shutter :**

In normal shutter mode (when random trigger shutter mode is OFF), it becomes a rolling shutter.

#### **- Rolling shutter**

Exposure starts sequentially from the first line.

The exposure time is the manual set value of the electronic shutter.

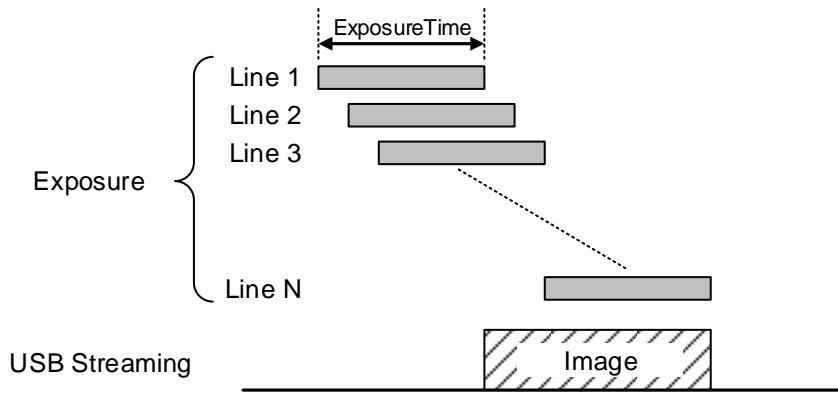

### **5.13 Trigger Delay**

You can add the delay between trigger signal input and the start of exposure.

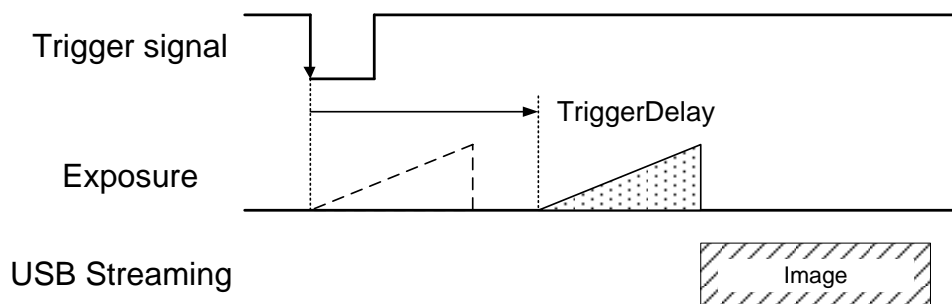

### 5.14 AntiGlitch – AntiChattering

AntiGlitch and AntiChattering functions filter noise and unstable state of the digital input (trigger signal).

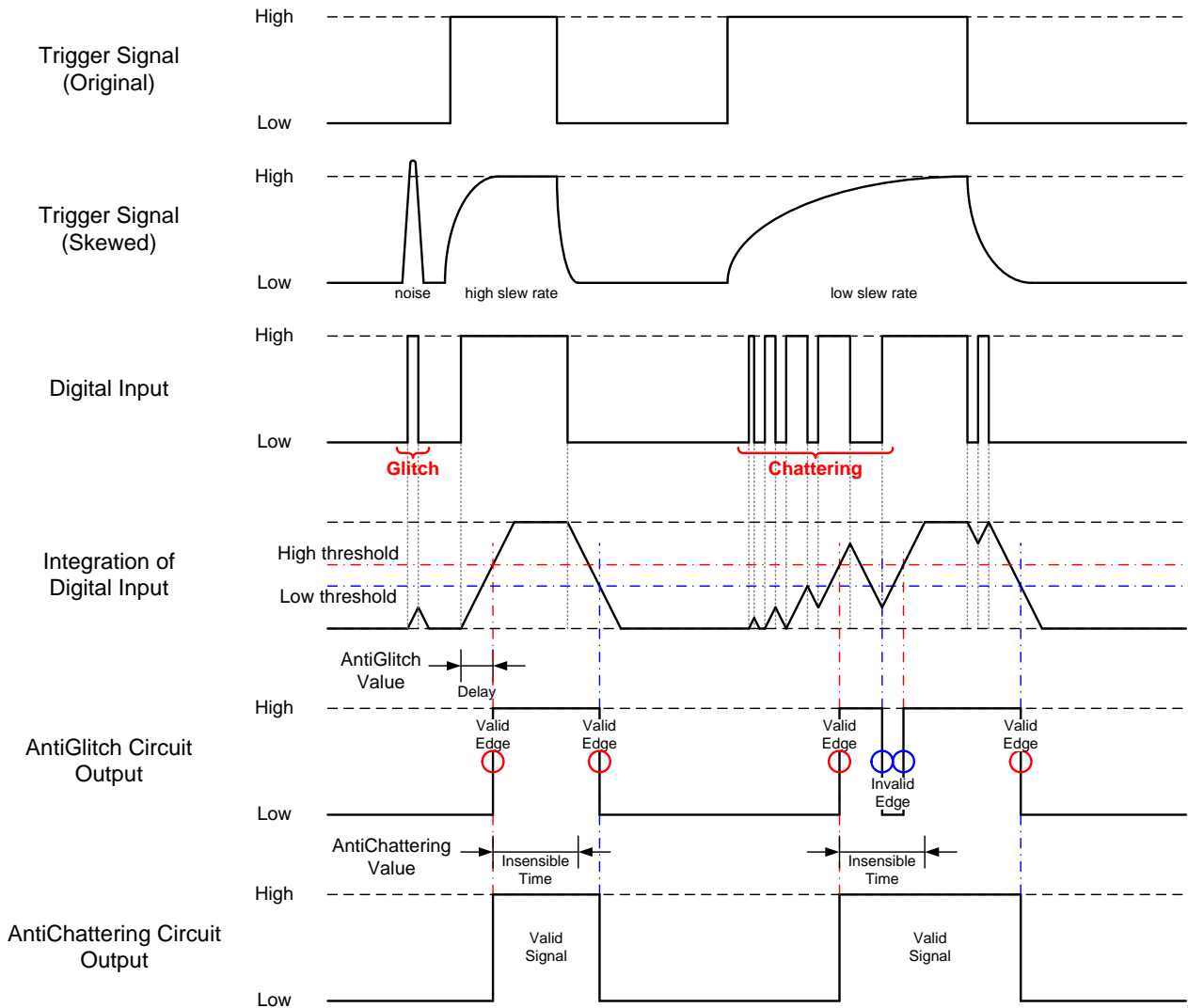

## 5.15 Event

Camera notifies FrameTrigger status and other information by USB3 Vision Event Packet.

- FrameTrigger : Reception of Frame Start Trigger
- FrameTriggerError : Rejection of Frame Start Trigger
- FrameTriggerWait : Start of waiting for Frame Start Trigger
- FrameTransferStart : Start of transferring streaming data
- FrameTransferEnd : End of transferring streaming data
- ExposureStart : Start of Exposure
- ExposureEnd : End of Exposure
- Timer0Start : Start of Timer0
- Timer0End : End of Timer0

Events timing are as following chart.

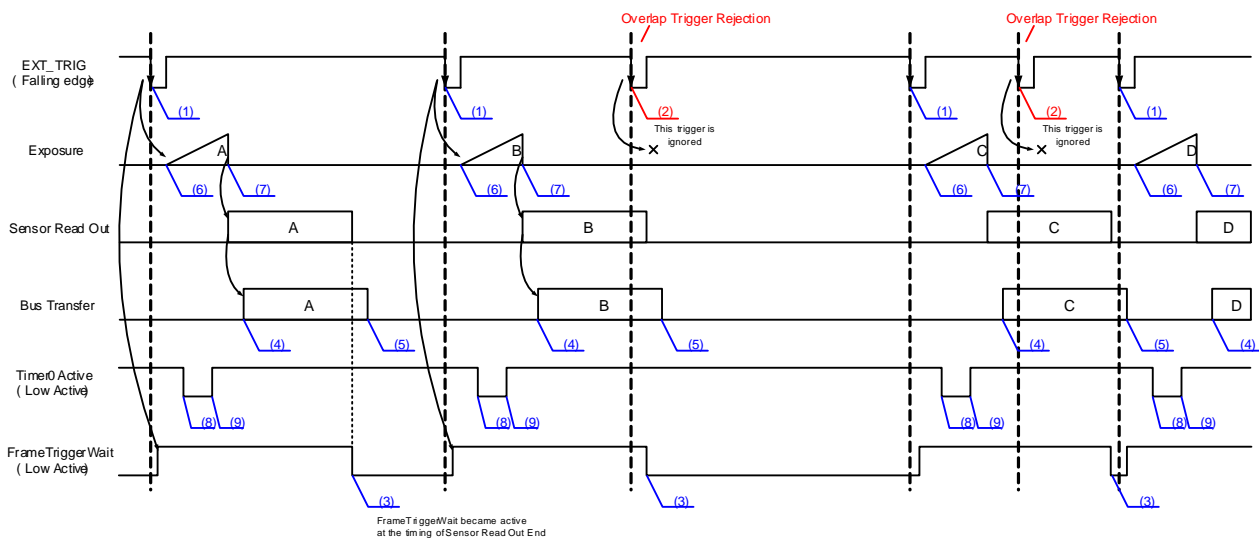

### Event Name

- (1) FrameTrigger : Reception of Frame Start Trigger
- (2) FrameTriggerError : Rejection of Frame Start Trigger
- (3) FrameTriggerWait : Start of waiting for Frame Start Trigger
- (4) FrameTransferStart : Start of transferring streaming data
- (5) FrameTransferEnd : End of transferring streaming data
- (6) ExposureStart : Start of Exposure
- (7) ExposureEnd : End of Exposure
- (8) Time0 Start : Start of Time0.
- (9) Time0End : End of Time0.

\*BU2006MG/BU2006MCF is not Overlap Trigger Rejection.



## 5.16 GPIO

Selected signals are output from GPIO pins of I/O connector. Following signals are selectable.  
Output signal is 5V CMOS.

- Timer0Active : This signal can be used as strobe control signal.  
The delay time and pulse width of this signal are configurable.
- UserOutput : Level selectable user output by register setting.
- ExposureActive : Period from exposure start to end.  
(See 7. Timing Chart for detail.)
- FrameActive : Period from exposure start to the CMOS transfer completion.
- FrameTransferActive : Period of transferring image data on USB bus.
- FrameTriggerWait : Indicating waiting a Random Trigger Shutter.  
An External trigger is input during this period,  
exposure starts immediately.

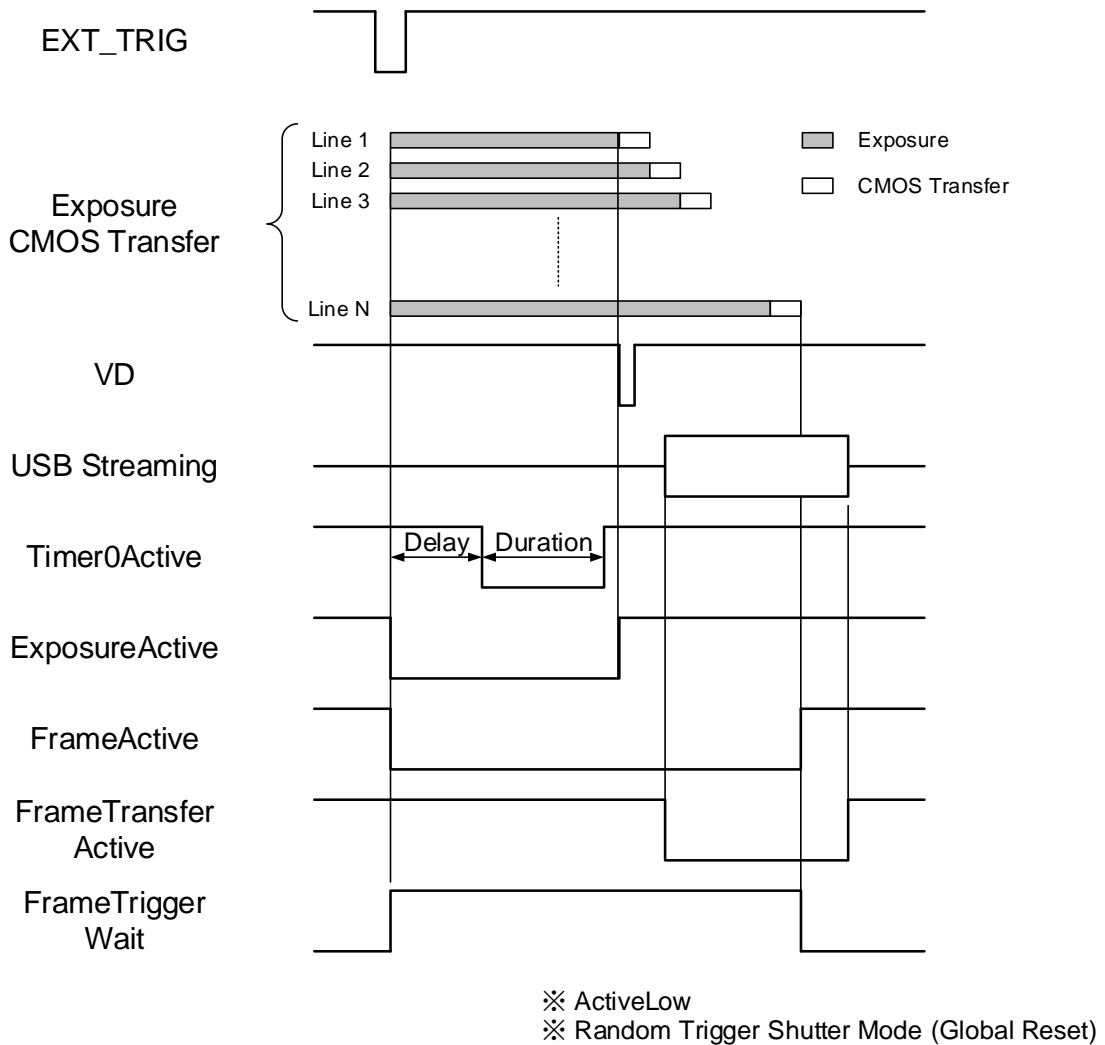

### 5.17 Scalable

Scalable is to read out arbitrary area of the image. Only single rectangle is selectable. Concave or convex shape is impossible. The number of selectable window is only one.

- Window size:  $\{A+4*m (H)\} * \{B+2*n (V)\}$

A, B = minimum unit size

m, n = integer

The window size is equal or less than maximum image size.

- Start address:  $\{4*i (H)\} * \{2*j (V)\}$

i, j = integer

The window size is equal or less than maximum image size.

Width and OffsetX unit size	4
Height and OffsetY unit size	2
Minimum unit size (H) * (V)	64 x 64
Maximum unit size (H) * (V)	5472 x 3648

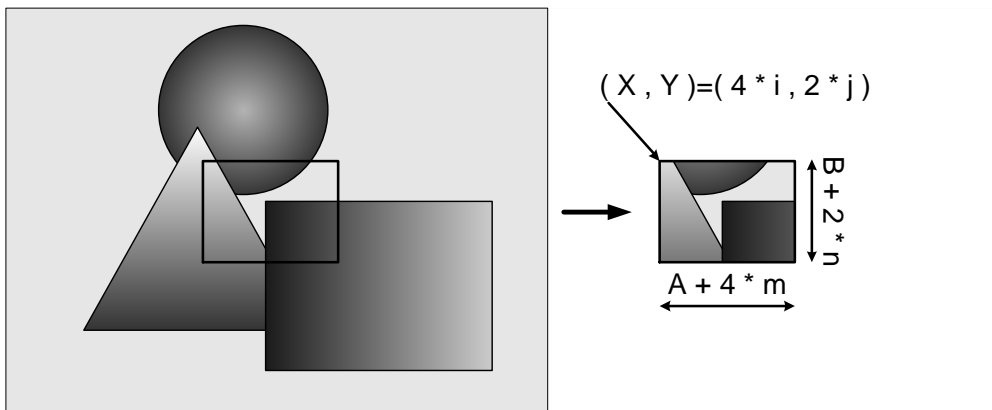

### 5.18 Binning

It supports the binning feature that the CMOS sensor has. The luminance of the neighbor pixels in horizontal/vertical are weighted, added and averaged. This feature achieves higher frame rate and improves S/N ratio. The maximum frame rate varies as follows.

Model Name	Format	Maximum frame rate
BU2006MG	Mono8	53.6 fps
	Mono10, Mono12	38.0 fps
BU2006MCF	Bayer8, Mono8	53.6 fps
	YUV 4:1:1	50.7 fps
	YUV 4:2:2	38.0 fps
	Bayer10, Bayer12	38.0 fps
	RGB, BGR	25.1 fps

#### **Notes on Defect pixel correction when binning is used :**

This product enables the defective pixel correction feature at factory setting after registering the X-Y coordinates of defective pixels in all-pixels scan mode. At the binning mode, the defective pixels will be possible to appear in unexpected coordinates by the weighted addition of the CMOS sensor. Please take measure to add the coordinates for defective pixel correction if it is problem.

### 5.19 Reverse

Image can be flipped in horizontal and/or vertical direction.

### 5.20 Defect Pixel Correction

Defect Pixel Correction is available up to 256 pixels.

### 5.21 Image Buffer

Camera stores images temporarily in image buffer, and read them out in arbitrary timing.

### 5.22 User Free Memory

A free memory area is available to read and write arbitrary data for user. Individual numbers can be assigned when multiple BU cameras are connected.

### 5.23 Test Pattern

Following test patterns are available.

Black	: Full screen 0 LSB (@ 8-bit)
White	: All pixels 255 LSB (@ 8-bit)
Grey A	: Full screen 170 LSB (10101010 <sub>B</sub> ) (@ 8-bit)
Grey B	: Full screen 85 LSB (01010101 <sub>B</sub> ) (@ 8-bit)
Horizontal ramp waveform	
Vertical ramp waveform	
Grey scale (B/W models only)	
Color Bar (Color models only)	

## 6. Specifications

### 6.1 Electrical specification

Model Name	BU2006MG
Imager	CMOS image sensor
Number of effective pixels (H) x (V)	5472 x 3648
Scanning area (H) x (V) [mm]	13.13 x 8.76 (1 type)
Pixel size (H) x (V) [ $\mu\text{m}$ ]	2.4 x 2.4
Scan method	Progressive
Electronic shutter method	Rolling shutter
Aspect ratio	3:2
Sensitivity	1210lx, F5.6, 1/19s
Minimum illuminance	F1.4, Gain +24dB, Video level 50%
	3lx
Gain	MANUAL, AGC (factory setting : MANUAL)
Setting range	0 to +24dB (factory setting : 0dB)
Black Level	-25 to 25% (factory setting : 0% [ 0LSB@8bit ])
Gamma	$\gamma=1.0$ to 0.45 (factory setting : $\gamma=1.0$ )
LUT	Input 12 bit, Output 12 bit
Image Buffer	256M Byte
User Setting Memory	7 channels
User Free Memory	64 Byte
Test Pattern	Black, White, Grey A, Grey B Horizontal ramp waveform, Vertical ramp waveform, Grey scale (factory setting : OFF)
Power supply	DC +5V $\pm$ 5% (from USB connector)
Power consumption ( at the all pixel readout )	2.7W (Maximum)

Model Name	BU2006MCF
Imager	CMOS image sensor
Number of effective pixels (H) x (V)	5472 x 3648
Scanning area (H) x (V) [mm]	13.13 x 8.76 (1 type)
Pixel size (H) x (V) [ $\mu\text{m}$ ]	2.4 x 2.4
Scan method	Progressive
Electronic shutter method	Global shutter
Aspect ratio	3:2
Sensitivity	1940lx, F5.6, 1/19s
Minimum illuminance	F1.4, Gain +24dB, Video level 50%
	4lx
Gain	MANUAL, AGC (factory setting : MANUAL)
Setting range	0 to +24dB (factory setting : 0dB)
Black Level	-25 to 25% (factory setting : 0% [ 0LSB@8bit ])
Gamma	$\gamma=1.0$ to 0.45 (factory setting : $\gamma=1.0$ )
Hue	$-180^\circ$ to $180^\circ$ (factory setting : $0^\circ$ )
Saturation	x0 to x2 (factory setting : x1.0)
White balance	MWB, OPWB (factory setting : MWB)
Effective range	2,500 to 6,500K
MWB setting format	R/B gain independent setting
OPWB effective area	The center of the image output : 1 to 100% (factory setting : 100%)
LUT	Input 12 bit, Output 12 bit
Image Buffer	256M Byte
User Setting Memory	7 channels
User Free Memory	64 Byte
Test Pattern	Black, White, Grey A, Grey B Horizontal ramp waveform, Vertical ramp waveform, Color bars (factory setting : OFF)
Power supply	DC +5V $\pm$ 5% (from USB connector)
Power consumption ( at the all pixel readout )	2.9W (Maximum)

## 6.2 Electronic shutter specification

Model Name	BU2006MG	
Shutter system		
Normal Shutter	Rolling Shutter	
Random Trigger Shutter	Global Reset	
Exposure time	MANUAL, AE (factory setting : MANUAL)	
MANUAL	At the all pixel readout	56.4 $\mu$ s to 16s (factory setting : 51999.4 $\mu$ s)
	Binning setting	20.1 $\mu$ s to 16s
Exposure time unit	At the all pixel readout	14.11 $\mu$ s
	Binning setting	5.03 $\mu$ s
AE effective range	At the all pixel readout	56.4 $\mu$ s to 1s
	Binning setting	20.1 $\mu$ s to 1s
AE effective area	The center of the image output: 1 to 100% (factory setting : 100%)	
AE Exposure value	-2.0EV to +1.5EV (factory setting : 0EV)	

Model Name	BU2006MCF	
Shutter system		
Normal Shutter	Rolling Shutter	
Random Trigger Shutter	Global Reset	
Exposure time	MANUAL, AE (factory setting : MANUAL)	
MANUAL	At the all pixel readout	
	Bayer8, Mono8	56.4 $\mu$ s to 16s
	YUV 4:1:1	
	YUV 4:2:2	
	Bayer10, Bayer12	
	RGB, BGR	64.7 $\mu$ s to 16s (factory setting : 51988.1 $\mu$ s)
Binning setting	20.1 $\mu$ s to 16s	
Exposure time unit	At the all pixel readout	
	Bayer8, Mono8	14.11 $\mu$ s
	YUV 4:1:1	
	YUV 4:2:2	
	Bayer10, Bayer12	
	RGB, BGR	16.18 $\mu$ s
Binning setting	5.03 $\mu$ s	
AE effective range	At the all pixel readout	
	Bayer8, Mono8	56.4 $\mu$ s to 16s
	YUV 4:1:1	
	YUV 4:2:2	
	Bayer10, Bayer12	
	RGB, BGR	64.7 $\mu$ s to 1s
Binning setting	20.1 $\mu$ s to 1s	
AE effective area	The center of the image output: 1 to 100% (factory setting : 100%)	
AE Exposure value	-2.0EV to +1.5EV (factory setting : 0EV)	



### 6.3 Random Trigger Shutter specification

Trigger Mode	External trigger, Software trigger (factory setting : External trigger)
External trigger	Input via I/O connector
Software trigger	USB3 Vision command control
Exposure time	Edge mode, Bulk mode (factory setting : Edge mode)
Edge mode	The exposure time depends on the MANUAL Exposure time setting
Bulk mode	The exposure time depends on the MANUAL Exposure time setting
Number of Exposures in Bulk mode	255 times (maximum)
Sequential Shutter	16 entries (maximum)
Trigger Delay	0 to 2000000 $\mu$ s (factory setting : 0 $\mu$ s)
AntiGlitch	90ns to 2ms (factory setting : 90ns)
AntiChattering	2 $\mu$ s to 2ms (factory setting : 2 $\mu$ s)

#### 6.4 GPIO Input signal specification

I/O Connector Pin No,	4 Pin : Line0
Input circuit	<p>The diagram illustrates the internal circuit for the 4-pin connector. Pin 4 is connected to a DC3.3V supply through a 10kΩ pull-up resistor and a diode. Pin 3 is connected to a switch and a 0V ground. A dashed line labeled 'Inside' indicates the internal components.</p>
Input level	Low: 0 to 0.5V, High: 2.0 to 24.0V
Polarity	High active / Low active (factory setting : Low active)
Pulse width	50μs (minimum)
Input impedance	High impedance

## External trigger input recommended circuit:

### 1) Isolated I/F

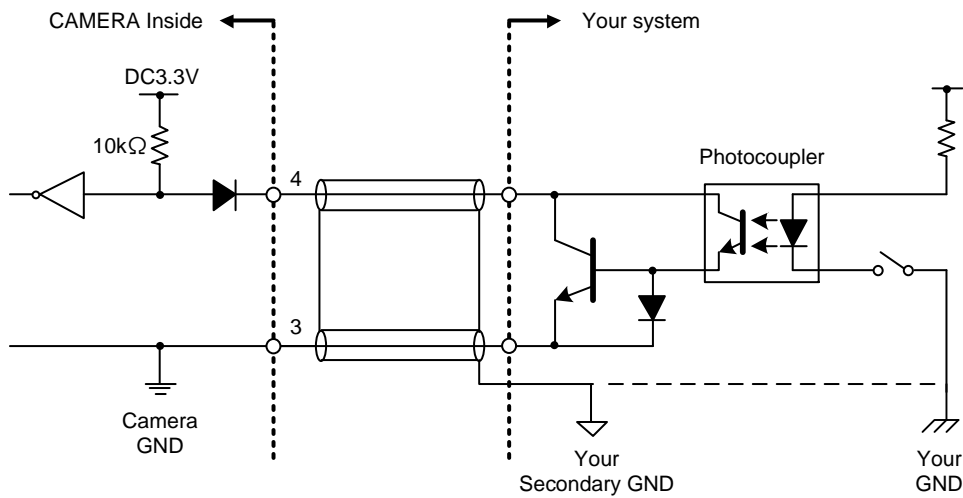

### 2) Non-isolated I/F

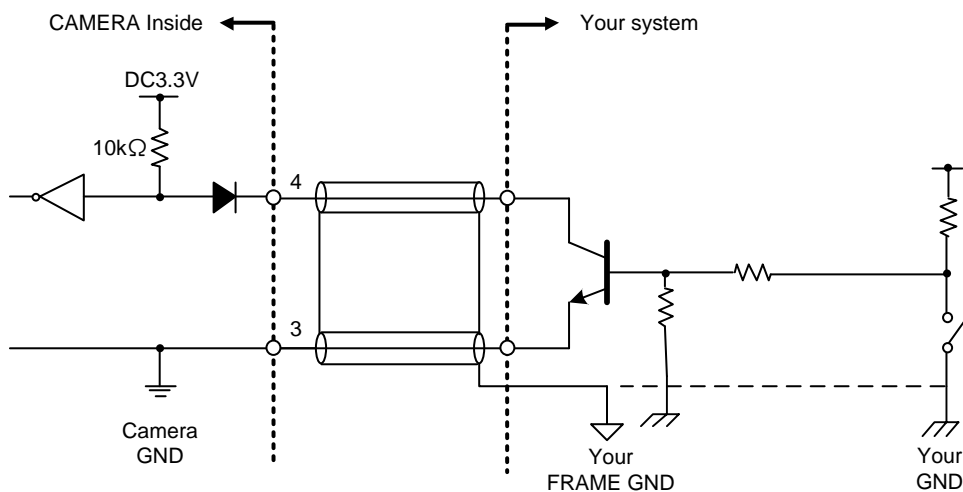

- The recognition of the trigger signal depends on the length, characteristic or driving current of the cable. Therefore please confirm your system about those conditions.
- Pin 3 is signal ground. It is conducted with camera frame.  
Using shield cable, terminal processing of the shield is referred as above.
- Please confirm the EMC adaptability in whole of your system.

## 6.5 GPIO Input / Output signal specification

I/O Connector Pin No.	1 Pin : Line2
GPIO signal (LineMode)	Input / Output (factory setting : Output*)
Input / Output circuit	
Input signal specification	
Input level	Low: 0 to 0.5V, High: 4.0 to 5.0V
Polarity	High active / Low active (factory setting : Low active)
Pulse width	50μs (minimum)
Input impedance	High impedance
Output signal specification	
Output signal (LineSource)	Off, Timer0Active, UserOutput, ExposureActive, FrameActive, FrameTransferActive, FrameTriggerWait (factory setting : Off)
Output level	5V CMOS
Maximum Current	+/-32mA
Polarity	High active / Low active (factory setting : Low active)
Timer0Active	
Delay	0 to 2000000μs (factory setting : 0μs)
Duration	0 to 2000000μs (factory setting : 0μs)
TimerTriggerSource	Line0Active, ExposureStart, FrameTrigger

\* Even if LineMode is set as Output, the input signal to Line2 is valid when LineSource is set as Off.

### **Note on Input Level:**

- Line0 and Line2 have a different input level. Please use input level within the voltage described in this specification.

## 6.6 GPIO Output signal specification

I/O Connector Pin No.	2 Pin : Line1
Output signal (LineSource)	Off, Timer0Active, UserOutput, ExposureActive, FrameActive, FrameTransferActive, FrameTriggerWait (factory setting : Off)
Output level	5V CMOS
Maximum Current	+/-32mA
Polarity	High active / Low active (factory setting : Low active)
Timer0Active	
Delay	0 to 2000000 $\mu$ s (factory setting : 0 $\mu$ s)
Duration	0 to 2000000 $\mu$ s (factory setting : 0 $\mu$ s)
TimerTriggerSource	Line0Active, ExposureStart, FrameTrigger

## 6.7 Interface specification

Interface	USB 3.1 Gen1 (Only SuperSpeed is supported)
Transmission speed	5Gbps (Maximum)
Protocol	USB3 Vision

## 6.8 LED states

Camera state	Lamp indication
No power	Off
Link detection in progress	Fast flash green (ON:20ms, OFF:60ms)
Connection Error	Flash alternate red / green
SuperSpeed connected, but no data being transferred	Flash green (ON: 200ms, OFF: 800ms)
SuperSpeed connected, waiting for trigger	Flash orange (ON: 200ms, OFF: 800ms)
Data being transferred	Fast flash green (ON:60ms, OFF:20ms)
Error during data transfer	Solid Red (Time period: 500ms)
Stand-by	Super slow flash orange (ON:200ms, OFF: 2800ms)

## 6.9 Image output format

Model Name		BU2006MG
Image output format		Mono8, Mono10, Mono12(factory setting : Mono8)
Number of Video out pixels (H) × (V)		5472 × 3648
Maximum frame rate (at the all pixel readout)	Mono8	19 fps
	Mono10, Mono12	9.5 fps

Model Name		BU2006MCF
Image output format		RGB, BGR, YUV4:2:2, YUV4:1:1, Bayer8, Bayer10, Bayer12, Mono8 (factory setting : RGB )
Number of Video out pixels (H) × (V)		5472 × 3648
Maximum frame rate (at the all pixel readout)	Bayer8, Mono8	19 fps
	YUV4:1:1	12.7 fps
	YUV4:2:2	9.5 fps
	Bayer10, Bayer12	9.5 fps
	RGB, BGR	6.3 fps
BayerProcessingMode		Full, Partial, Raw (factory setting : Full)

### **Notes on Dropping Frames:**

- Depends on your PC or USB interface card configurations, images may not be captured normally (e.g. dropping frames may occur). In this case, change to frame rate setting lower.

## 6.10 Event notification

Event name	FrameTrigger, FrameTriggerError, FrameTriggerWait FrameTransferStart, FrameTransferEnd ExposureStart, ExposureEnd Timer0Start, Timer0End
Event notification delay	approx. 10us later from the event occurs
Time stamp unit	16.7ns (60.0MHz)

### 6.11 Machine external specification

Dimensions	29 mm(W) * 29 mm (H) * 16 mm (D) (Not including protrusion)
Mass	approx. 34g
Lens mount	C-mount
Flange back	17.526mm
Camera body grounding insulation status	Conductive between circuit GND and camera body

### 6.12 Operation Ambient conditions

Operation assurance	Temperature: 0°C to +40 °C, Camera housing temperature: less than 60 °C Humidity: 10% to 90% (no condensation)
Storage assurance	Temperature : -20 to +60 Celsius Humidity : +90% or less (no condensation)
EMC condition	EMI (Electro-Magnetic interference) : EN61000-6-4, FCC Part 15 Subpart B Class A EMS (Electro-Magnetic susceptibility) : EN61000-6-2

#### **Notes on Heat Dissipation:**

- The temperature of camera housing must be kept less than 60 Celsius.  
Please provide sufficient heat dissipation depending on your installation.

#### ● Compliance Information

- The identification of the product, model number BU2006MG / BU2006MCF.
- This device complies with Part 15 of the FCC Rules.

Operation is subject to the following two conditions:

(1) This device may not cause harmful interference, and (2) this device must accept any interference received, including interference that may cause undesired operation.

- Company Name: Toshiba Teli Corporation
- Address: 4-7-1, Asahigaoka, Hino-shi, Tokyo 191-0065. Japan
- Telephone number: +81-42-589-8771
- URL: <https://www.toshiba-teli.co.jp/en/>

#### ● Changes or Modifications

Changes or modifications not expressly approved by the party responsible for compliance could void the user's authority to operate the equipment.

- Class A Statement

Statement for Class A equipment:

NOTE: This equipment has been tested and found to comply with the limits for a Class A digital device, pursuant to part 15 of the FCC Rules. These limits are designed to provide reasonable protection against harmful interference when the equipment is operated in a commercial environment. This equipment generates, uses, and can radiate radio frequency energy and, if not installed and used in accordance with the instruction manual, may cause harmful interference to radio communications. Operation of this equipment in a residential area is likely to cause harmful interference in which case the user will be required to correct the interference at his own expense.

**Notes on Conformity of the EMC:**

The adaptability of the safety standard of this camera is assured in the condition of combination with the following parts:

- USB Cable                      USB3-KR1-A-MBS-030                      (OKI Electric Cable Co., Ltd.)
- e-CON Cable                  3.0m, Shield cable                      (Fabricated parts)

Parts:

- e-CON connector            37104-3163-000 FL                      (3M Japan Limited)
- Shielded wire              UL1533 (AWG28)                      (Hitachi Cable, Ltd.)

Connection:

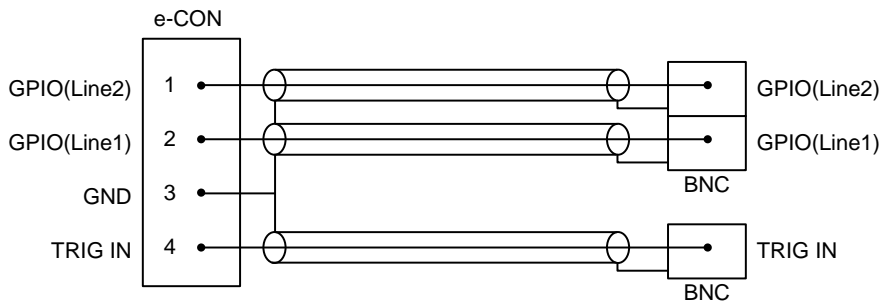

Please confirm the EMC adaptability when it combines with parts other than them.

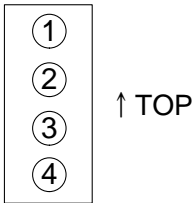

### 6.13 Connector pin assignment

<b>USB 3.1 Gen1 interface connector</b>			
Connector model: WMUR-10F6L1PH5N (WIN WIN PRECISION INDUSTRIAL)			
Pin No.	I/O	Signal Name	Function
1	-	VBUS	Power
2	I/O	D-	USB2.0 differential pair
3	I/O	D+	
4	-	NC	Not connected
5	-	GND	Ground for power return
6	O	SSTX-	SuperSpeed transmitter differential pair
7	O	SSTX+	
8	-	GND_DRAIN	Ground for SuperSpeed signal return
9	I	SSRX-	SuperSpeed receiver differential pair
10	I	SSRX+	
<b>I/O Connector</b>			
Connector (Camera side)		37204-62B3-004PL (3M Japan Limited) or equivalent	
Matching connector (Cable side)		Connectors which conformed to e-CON e.g. 37104 series (3M Japan Limited), RITS 4P series (TE Connectivity Ltd.)	
* Matching connector is not an accessory of this product.			
Pin assignment			
			
* Above figure is connector view from insert side.			
Pin No.	I/O	Signal Name	Function
1	I/O	Line2	GPIO Input / Output
2	O	Line1	GPIO Output
3	-	GND	Ground
4	I	Line0	GPIO Input

### 6.14 Typical spectral response

The lens characteristics and light source characteristics is not reflected in table.

<BU2006MG>

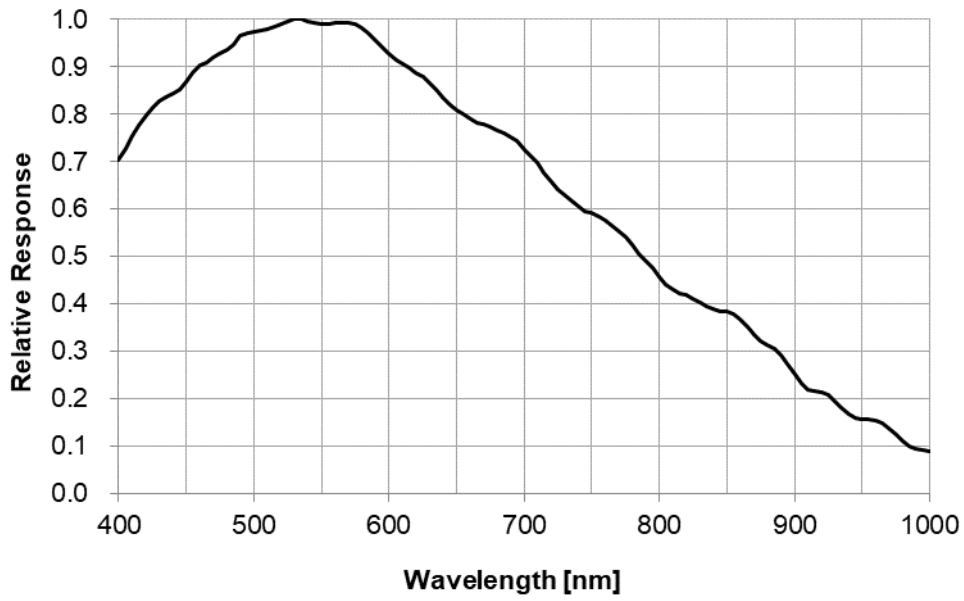

<BU2006MCF>

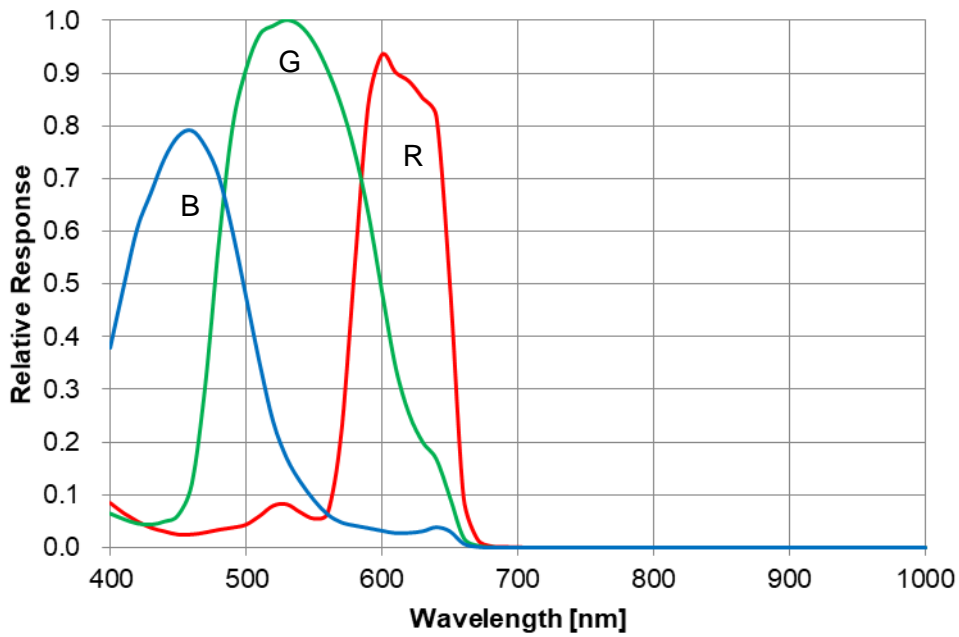

## 7. Timing chart

Image data outputs are transferred with USB bulk transfer. Timing numerical value below is described by absolute prerequisite that camera can use transmission band without restriction of other device. When there is other device on the same bus, the value described below is not guaranteed.

### 7.1 In Manual shutter mode (at all pixels readout)

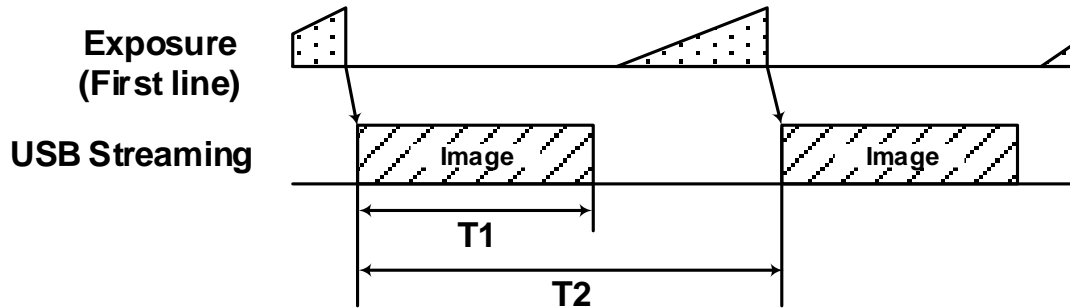

Model Name	Format	T1 [ms]	T2 [s]
BU2006MG	Mono8	51.8	1/(Frame Rate setting)
	Mono10, Mono12	97.8	
BU2006MCF	Bayer8, Mono8	51.8	
	YUV 4:1:1	73.3	
	YUV 4:2:2	97.8	
	Bayer10, Bayer12	97.8	
	RGB, BGR	147.0	

## 7.2 In Random Trigger Shutter mode

- Edge mode / Bulk mode (at all pixels readout)

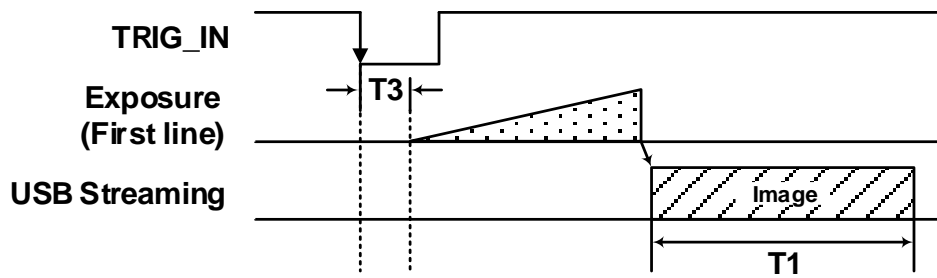

Model Name	Format	T3 [ $\mu$ s]
BU2006MG	Mono8	85.0
	Mono10, Mono12	
BU2006MCF	Bayer8, Mono8	85.0
	YUV 4:1:1	
	YUV 4:2:2	
	Bayer10, Bayer12	97.6
RGB, BGR		

\* The value of T1 is the same as the value of normal shutter mode.

\* T3 are typical value.

### **Notes of Random Trigger Shutter :**

- In the period when FrameTriggerWait (refer to GPIO output signals) signal is inactive, user must not input external trigger signal to this camera.
- When the interval of the input trigger signal is extremely short, or when the trigger signal is noisy, there is a possibility of causing the malfunction. In this case, please input a proper trigger signal.

## 8. Warranty rules

### 8.1 Warranty term

Warranty term is 36 months after your purchase. We may assume the date of the purchase from our shipping date when the date is unidentified.

### 8.2 Limited Warranty

Free warranty is not applicable for the troubles, damages or losses caused by the cases of the followings, even if it is during the warranty term.

1. Natural exhaust, wear or degradation of a component parts
2. Handling against the instructions and conditions described in the instruction manual
3. Remodeling, adjustment and the part exchange. (including the opening of the enclosure box and the alteration)
4. Using the accessories not included with the product or our non-designated optional articles
5. Damages caused during the transportation or deficiency of the handling such as drop or fall of the products after the products having been transferred to customers, leaving the products to corrosive environment such as sunlight, fire, sand, soil, heat, moisture, or an inappropriate storing method
6. A fire, an earthquake, a flood, a lightning, or other natural disasters, pollution and a short circuit, abnormal voltage, excessive physical pressure, theft, other accident
7. When connected to a product which is not recommended
8. When connected to the power supply which is not suitable
9. Forgery product, products which does not have proper serial number, products of which serial number is forged, damaged or deleted
10. All defects that happened after the expiration for a warranty term

## 9. Repair

### 9.1 Repair Methods

Exchange to a replacement or an equal function product.

### 9.2 Repair request methods

On the occasion of a repair request, please download the "Failure situation report sheet" from our website, fill in the necessary items and return it together with the defective product.

Repair Request Methods

<https://www.toshiba-teli.co.jp/en/support/failure-situation.htm>

Please read the following instructions carefully.

1. Please return our product alone, taking out of your equipment in case that our product is installed to an equipment
2. We are unable to return the information such as your own serial numbers, control number, the identification seal, if it is attached to the returned products. Please keep record before you return the product.
3. As the data saved in the camera will not be kept after the repair, please take out data before return.
4. We are unable to accept the cancellation after the repair request by the customer's reason.
5. About the repair product shipping expenses, please bear the charges when you return the product to us. We bear the charges to you from us only for a warranty period.
6. We are unable to accept your request of a delivery date and time of the product return, or the delivery method.
7. We are unable to accept a trouble factor investigation, the request of the repair report.
8. We accept a repair of out of warranty product, if it is repairable.
9. The proprietary rights of the repair request products after the exchange repair belong to us.
10. The immunity from responsibility of the product is applied in the repair completion products.

\* Please refer for the inquiry about the software to our homepage or sales personnel.

## 10. Outline Drawing

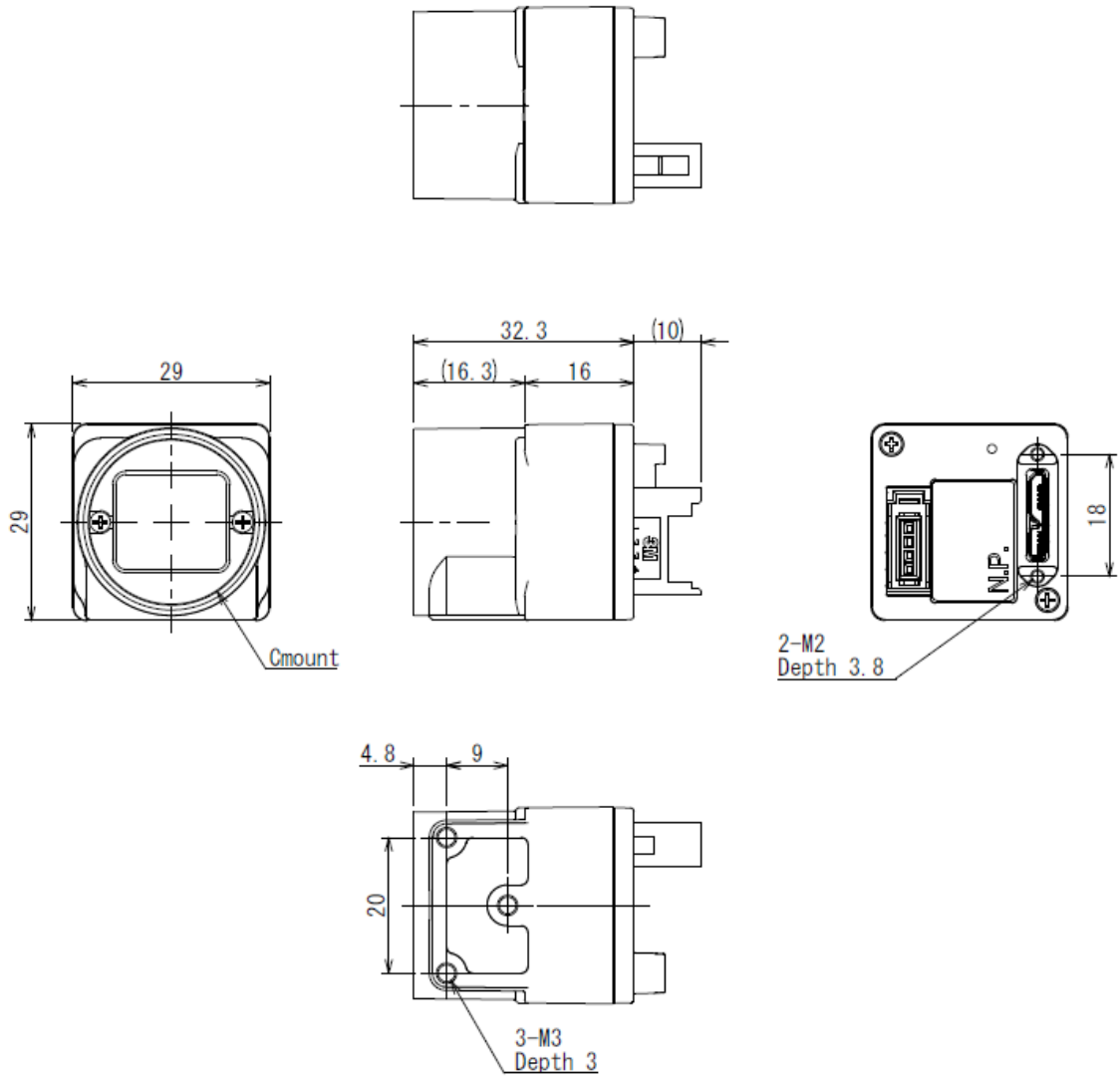

### Specification

Main material : Aluminum die-cast metal  
Processing : Cation coating (black)