



B/W CCD Camera Model CS8550Di-50 Operation Manual

Thank you for purchasing our CS8550Di-50 B/W CCD camera. This operation manual contains many important information such as how to use this equipment correctly and safely. Please read through this manual carefully. After reading, keep this manual by the side of your equipment for your future reference.

TOSHIBA TELI CORPORATION

BEFORE USE - GENERAL SAFETY INSTRUCTIONS

This instruction manual contains important information for the operator (user) and/or people around him/her to avoid personal injury, or property damage to him/her or people around him/her by using this product correctly. Prior to use, read this operation manual carefully to fully understand its instructions for correct use.

OWNER'S RECORD

Please fill in the blank below the model name and product serial number, which is found on bottom chassis of your device. Keep this number for your record.

Model Name _____

Serial No. _____

WARNINGS & CAUTIONS

[Definition of markings]
The meaning of each mark used in this instruction manual is given below.

	DANGER This mark warns the user that improper use, indicated with this mark, may cause death or severe personal injuries against the user or people around him/her.
	CAUTION This mark warns the user that improper use, indicated with this mark, may cause personal injuries (*1) or material damages (*2) against the user or people around him/her.

- Notes
- *1 : Personal injuries mean wounds, burns, electric shocks, and others for which the person injured need not to be hospitalized nor to be cared for the long term.
 - *2 : Material damages mean any direct or consequential damages related to property or material loss.

	This mark indicates what the user SHOULD NOT DO . The details of things which the user should not do are described next to this mark.
	This mark indicates what the user MUST DO . The details of things which the user must do are described next to this mark.
	This mark indicates that the user must be alert against a possible DANGER . The details of the danger which the user must be aware of are described next to this mark.
	This mark indicates that the user are given a CAUTION against possible hazards. The details of the caution which the user must be aware of are described next to this mark.

Handling Precautions

	DANGER If any overheating sign is observed, discontinue use immediately. In the event that smoke, smell, or any other overheating sign is observed, turn its power switch OFF immediately, and remove its camera cable from camera connector. Do NOT try to continue to use your camera. To do so in spite of a clear sign of a malfunction invites a fire, an electric shock hazard, or any other serious damage. In such case, after confirming that there is no risk of a fire accident, contact us or our dealer/distributor through which you purchased this device for repair service. To avoid hazard, do NEVER attempt to repair it yourself.
	If any malfunctioning sign is observed, discontinue use immediately. Do NOT try to use this device when it is obviously malfunctioning. (Example: No images on the monitor) In the event of a malfunction, turn its power switch OFF immediately, and remove its camera cable from camera connector. In such case, contact us or our dealer/distributor through which you purchased this device for repair service.
	If any liquid gets into the device, discontinue use immediately. In the event that water, or any other type of liquid gets into the body, do NOT try to continue to use the device. To do so invites a fire or an electric shock hazard. In such case, turn its power switch OFF immediately, and then remove its camera cable from camera connector. After that, contact us or our dealer/distributor through which you purchased this device for repair service/technical advice.
	Do NOT disassemble this device. Do NOT attempt to pull apart, repair, or modify your camera yourself. To do so might lead to a fire or an electric shock accident. Contact us or the dealer/distributor from which you purchased the device for repair/modification.
	Do NOT supply any power other than specified. This device is designed to work only under specified voltage. Do NOT attempt to supply the device with power other than specified. Supplying the device with any unspecified power invites a fire or an electric shock hazard. (CS8550Di-50 --- DC+12V)
	Do NOT use the camera in a high-humidity environment. Do NOT place your camera near a humidifier, or in other high-humidity environment. To do so might cause a fire or an electric shock accident.
	Do NOT use any optional unit other than manufacturer-supplied one. We disclaim any responsibility for damages or losses incurred by user due to the use of unauthorized / unofficial option units supplied by a third-party.

Handling Precautions

	CAUTION If the camera is operated in the electromagnetic field, there may be cases where beat noises (vertical, horizontal, or oblique stripes) appear in the video output. In that case, take preventive measures on the electromagnetic-wave generating source so that your camera do not receive the interference by the electromagnetic-wave. Take extra precautions against electromagnetic-wave-interference if your camera is used with a servomotor, inverter, or other electromagnetic-wave-generating equipment.
	CAUTION Avoid giving a strong shock against the camera body. It might cause a breakdown or damage. If your camera is used in a system where its camera head is subjected to strong repetitive shocks, its camera head is possible to break down. If you intend to use your camera in such a situation, make sure to use an optional camera-connector-fixing-hardware to connect the connector-plug to the camera body.
	CAUTION When the camera is not in use, put a lens or a lens-cap onto the camera head so that the image pickup plane of CCD is protected from dust, foreign object, or any other flaw-causing object. If the glass plane (image pickup plane) gets dirty, clean it with a cotton swab. When it needs to be cleaned with a cleaner, be sure NOT to use any organic solvent other than ethyl alcohol. As a countermeasure against condensation, when the camera is moved from a warm condition/environment to a cold one, take appropriate precautions to prevent condensation from forming on the camera.
	CAUTION Do not pull strongly the camera cable/camera-head nor swing it. The stress from pulling or swinging may cause damage in the coating of the cable, or breaks in the inside wires.
	CAUTION Avoid short-circuiting signal output. Otherwise, it may cause a malfunction.
	CAUTION If too much amount of light, (= the incoming light amount of 100 times or greater in comparison with standard light) enters CCD image pickup plane, video output might not be obtained. In such a case, take measures to reduce the amount of incoming light.
	CAUTION Do NEVER expose its camera head to any intensive light (such as direct sunlight). Otherwise, its inner image pickup device might get damaged.

	CAUTION When mounting a lens, take extra caution so that the lens is not tilted, nor does flaw exist at the lens-mount-screw part. Also check to confirm that no dirt nor other foreign object is put inside. Improper mounting might cause the parts to become locked.
	Wastes of this product should be separated and discarded in compliance with the various national and local ordinances.

RESTRICTION FOR USE

In the case where a malfunction of this camera (e.g. video output cut-off) can be expected to lead to a significant accident, avoid using this device for such system build-in use.

DISCLAIMER (LIMITED WARRANTY)

We assume no responsibility and shall be held harmless for damage or loss incurred by the user in the following cases.

- In the case where damage or loss is caused by fire, earthquake, or other acts of Gods, acts by a third party, misuse by the user deliberately or erroneously, or use under extreme operating conditions.
- In the case where any indirect, additional, consequential damages (e.g. loss of expected interest, suspension of business activities) are incurred as results of a malfunction or non-functioning of this device, we shall be exempted from assuming responsibility for such damages.
- In the case where damage or loss is caused by incorrect use which is not in line with the instructions given in this operation manual.
- In the case where damage or loss is caused by a malfunction resulting from bad connection with other equipment.
- In the case where damage or loss is caused by repair or modification done by the user.

IMPORTANT SAFETY INSTRUCTIONS
(1) This device is designed and guaranteed to work under the temperature range of 0 through 40 degree C. Avoid using the equipment beyond that limits.
(2) Do NOT expose the camera's image-pickup-plane to sunlight or other intense light directly. Its inner CCD (charge-coupled device) might be damaged.
(3) In the event that any abnormal condition is observed, turn the power switch OFF immediately. Do NOT try to continue to use the camera. To do so in spite of clear signs of malfunction invites a fire, an electric shock hazard, or any other serious damage to the camera. In such case, contact us or our dealer/distributor from which you purchased the camera for repair service.
(4) To clean the body of this equipment, make sure to turn the power switch OFF first. To remove stubborn stains, use a soft cloth soaked in diluted acid-free detergent. After that, clean with a dry cloth.
(5) In case the image-pickup-plane should be settled with fine dust, dirt, or scratched, ask our distributor for technical advice.

Following information is only for EU-member states:

The use of the symbol indicates that this product may not be treated as household waste. By ensuring this product is disposed of correctly, you will help prevent potential negative consequences for the environment and human health, which could otherwise be caused by inappropriate waste handling of this product. For more detailed information about the take-back and recycling of this product, please contact your supplier where you purchased the product.

	"This symbol is applicable for EU member states only"
--	---

This device complies with Part 15 of the FCC rules. Operation is subject to the following two conditions: (1) This device may not cause harmful interference, and (2) This device accept any interference received, including interference that may cause undesired operation.

This equipment has been tested and found to comply with the limits for a class A digital device, pursuant to Part 15 of the FCC Rules. These limits are designed to provide reasonable protection against harmful interference when the equipment is operated in a commercial environment. This equipment generates, uses, can radiate radio frequency energy and, if not installed and used in accordance with the instruction manual, may cause harmful interference to radio communications. Operation of this equipment in a residential area is likely to cause harmful interference in which case the user will be require to correct the interference at his own expense.

1. PRODUCT DESCRIPTION

Model CS8550Di-50 is a one-body type B/W CCD camera with a VGA format all-pixel-data readout CCD. This model has twice greater driving frequency of conventional cameras to achieve fast-speed data-processing. The model is suited for high-speed, high-resolution image processing use. Its compact, light-weight body is ideal for system integration.

2. FEATURES

- Double-speed scan**
This model reads out image-data twice as fast as conventional cameras do.
- All pixel's data readout**
With its built-in all-pixel-data-readout CCD, this model can read out image-data just in approximately 1/60 sec. A frame-shutter reads out all data even under RTS (Random Trigger Shutter) mode.
- High vertical resolution**
As all pixel's data are read out even under RTS mode (in 1/60 sec.), images with no deterioration in vertical resolution are obtained.
- Square grid pattern CCD**
Pixel's in CCD are aligned in square grid pattern. This makes it easier to perform computation correctly for image processing use.
- External Sync**
The camera is switched over to external synchronization operation automatically when external HD signal is input.
- Random trigger shutter function**
With a built-in RTS, the camera's CCD starts light-exposure in synchronization with external trigger signals. This function enables the camera to capture fast-moving subjects at constant position for precise image processing.
- Restart / Reset**
Under the restart / reset mode, this model can capture images at an arbitrary timing cued by external VD signal.
- Multiple shutter**
With this shutter, this model capture images at an arbitrary timing cued by external trigger signal, and then outputs video at an arbitrary timing cued by external VD signal.
- Partial-scan**
Under the partial scan mode, only 1/2 or 1/4 screen center portion of image information is read out, resulting in a faster operation.
- Ultra-compact & light-weight camera head**
The model features its ultra-compact and light-weight camera head, freeing you from your integration-space-problem. In addition, it has an excellent shock and vibration resistance.

3. CONFIGURATION

- Camera body 1
- Accessory
Manual 1

4. OPTION UNIT

- DC SYNC IN cable Model name : CPRC3700 [2m,3m,5m,10m]
- Camera adapter Model name : CA170
- Camera-mounting kit Model name : CPT8550
- Camera-connector fixing hardware

*Contact your dealer / distributor for details of option units.

*Conformity of an option part and EMC conditions

About the conformity of EMC standard of this machine, it has guaranteed in the conditions combined with the above-mentioned option part. When used combined parts other than specification of our company, I ask you to have final EMC conformity checked of a visitor with a machine and the whole equipment.

5. OPERATION MODE

- GAIN selection (Camera rear-panel SW [GAIN])**
Switches sensitivity setting
(1-1)FIX Factory-prefixed gain [F]
(1-2)MANU Gain is adjustable via the manual gain potentiometer (M.GAIN) [M]
- Video output mode selection (Camera rear-panel DIP SW [VIDEO])**
Switches video format
(2-1)1/60: 1/60s Non-interlace mode
As all pixels are read out in 1/60s, you will get images with the higher V resolution
(2-2)1/120: 1/120s 2:1 interlace MIX mode
As vertical pixels are added in readout, the sensitivity is same as that of 1/60s non-interlace mode during electronic shutter OFF. Twice greater sensitivity is obtained under shutter-speed range of 1/200 - 1/20000.
- TRIG selection (Camera rear-panel DIP SW [TRIG])**
Switches TRIG input signal polarity used under RTS mode
(3-1)POST Positive polarity (rising edge detection)
(3-2)NEGA Negative polarity (falling edge detection)
- RTS (Random Trigger Shutter) exposure selection [EXP]**
Switches light exposure mode under RTS mode
(4-1)FIX mode Rear DIP SW
Exposure-time control via rear-panel DIP switch
(4-2)PULSE W mode TRIG signal pulse width control
Exposure-time control via TRIG signal pulse width
- Shutter mode selection (Camera rear-panel DIP SW [SMODE] or TRIG signal IN [Automatic])**
Switches shutter mode
(5-1) NOR mode Normal electronic shutter
Exposure control via internal sync signal
High-speed shutter: From 1/20,000s through OFF (8 position)
(5-2) RDM mode Random trigger shutter
Exposure control via ext. trigger or ext. sync. input
Timing charts are shown below. (TRIG timing: Positive)
Notes: * RDM selection is automatic with TRIG status
** Neither under FIX nor PULSE W mode, RTS doesn't work if E-shutter speed SW is set in OFF position.

- Non-reset mode (Under internal sync / external sync --- Consecutive VD IN)**
Exposure starts at the timing of TRIG signal IN. After each exposure is completed, the camera outputs video at each next VD IN timing.

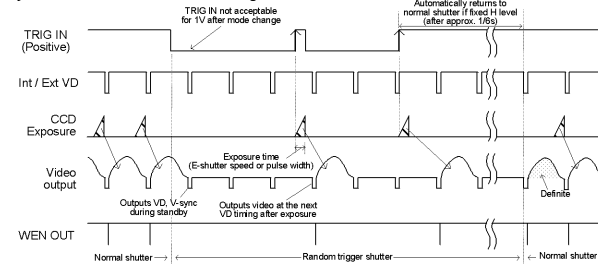

- Non-reset mode (Under external sync --- Single VD IN)**
After TRIG IN and exposure, the camera goes into standby until next ext. VD IN. Under 1/120s 2:1 interlace mode, video output field (ODD/EVEN) is determined by ext. VD falling edge and ext. HD phase.

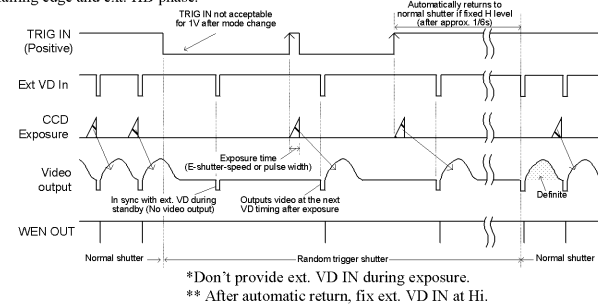

- V-reset mode (Under internal sync / external sync --- No VD IN)**
Exposure starts at the timing of TRIG signal IN. After each exposure is completed, the camera outputs video immediately by resetting VD. (HD is not reset) Under 1/120s 2:1 interlace mode, irrespective of TRIG IN phase, the camera always outputs ODD field image.

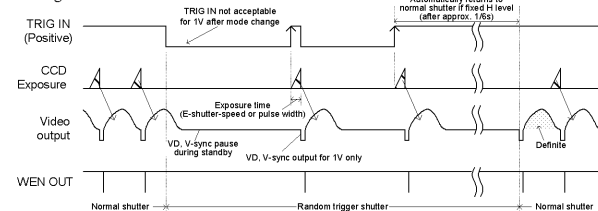

- SYNC reset mode (Under internal sync)**
Exposure starts at TRIG signal input timing, resets HD, and outputs video immediately after exposure by resetting VD.
* Available under FIX mode only.

Under 1/120s 2:1 interlace mode, irrespective of TRIG IN phase, the camera always outputs ODD field image.

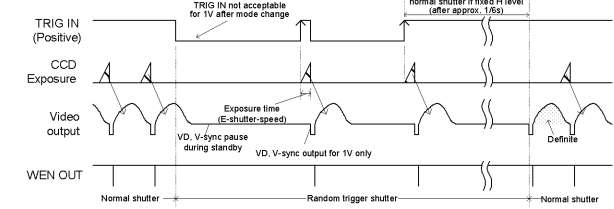

- MULTIPLE mode**
Multiple shutter operation is available by providing TRIG IN more than one time before ext. VD IN. (Non-reset mode, single VD, consecutive VD IN)

Under 1/120s 2:1 interlace mode, video output field (ODD/EVEN) is determined by ext. VD falling edge and ext. HD phase.

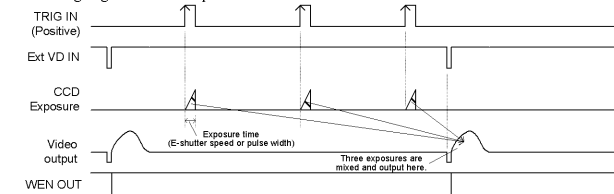

- Restart / Reset**
The restart / reset function is available with the ext. VD signal. You can get an arbitrary slower shutter speed than normal shutter and random trigger shutter.

Here are some notes;
* The shutter speed (exposure time) is determined by ext. VD signal interval.
** This function is enabled when the rear-panel shutter speed DIP SW is OFF.

*** Supply consecutive VD.

Under 1/120s 2:1 interlace mode, video output field (ODD/EVEN) is determined by ext. VD falling edge and ext. HD phase.

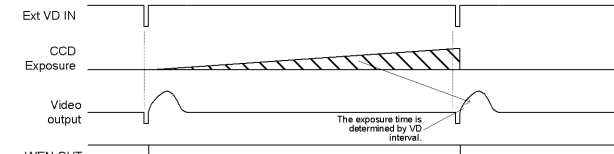

- Partial-scan mode selection (Camera rear-panel DIP SW [PART])**

Switches partial-scan mode

Note: Sometimes phenomenon called as "whiteout" occurs at the top of the screen when there is strong incident light entering in the wide area of a CCD, however, this is not a malfunction. If this occurs, reduce the amount of incoming rays.

- 1/2 Partial-scan (Rear-panel SW: 7-OFF, 8-ON) --- Screen center 1/2 readout**

□ 1/60s Non-interlace
Under 1/60s non-interlace mode, only the center portion of 227H out of the total effective lines 494H (excluding BLK time) is read out. Available both under external / internal mode.

- Under normal shutter (Electronic shutter OFF)
Notes: * Under ext. sync, the ext. VD should be 1V = 262H.
** Under normal shutter, set the rear-panel DIP SW #S, #6 in OFF.

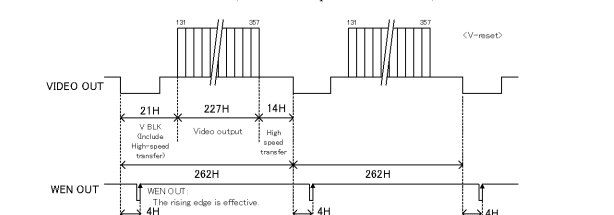

- Under other shutter modes

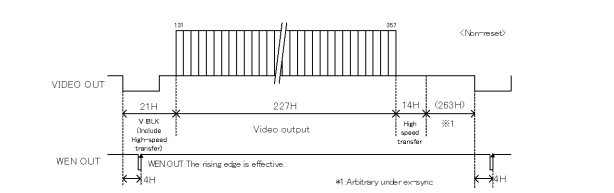

- 1/120s 2:1 Interlace
Under 1/120s interlace mode, only the center portion of 207H out of the total effective lines 485H (excluding BLK time) is read out. Available both under external / internal mode.

- Under normal shutter (Electronic shutter OFF)
Notes: * Under ext. sync, the ext. VD should be 1V = 131.5H.
** Under normal shutter, set the rear-panel DIP SW #S, #6 in OFF.

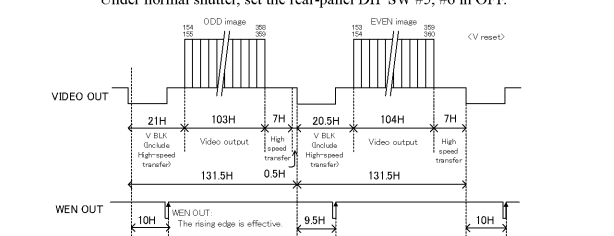

Under other shutter modes

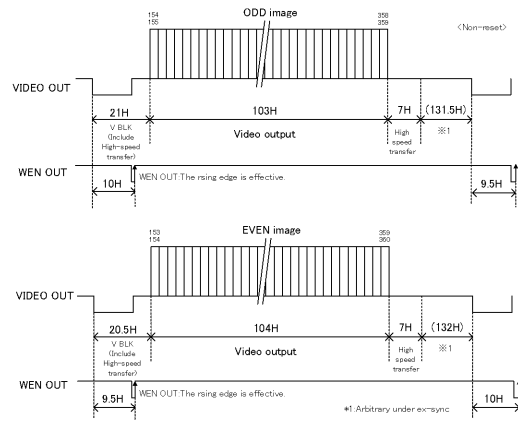

(6-2) 1/4 Partial-scan (Rear-panel SW: 7-ON, 8-ON) --- Screen center 1/4 readout

1/60s Non-interlace

Under 1/60s non-interlace mode, only the center portion of 81H out of the total effective lines 494H (excluding BLK time) is read out. Available both under external / internal mode.

Under normal shutter (Electronic shutter OFF)

Notes: * Under ext. sync, the ext. VD should be 1V = 131H.

** Under normal shutter, set the rear-panel DIP SW #5, #6 in OFF.

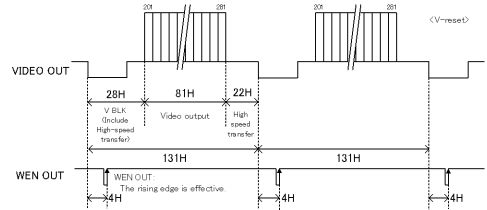

Under other shutter modes

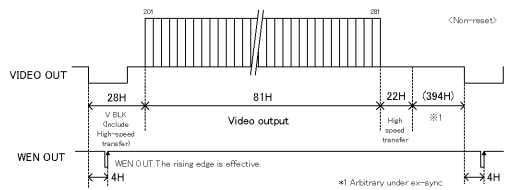

1/120s 2:1 Interlace

Under 1/120s interlace mode, only the center portion of 61H out of the total effective lines 485H (excluding BLK time) is read out. Available both under external / internal mode.

Under normal shutter (Electronic shutter OFF)

Notes: * Under ext. sync, the ext. VD should be 1V = 65.5H.

** Under normal shutter, set the rear-panel DIP SW #5, #6 in OFF.

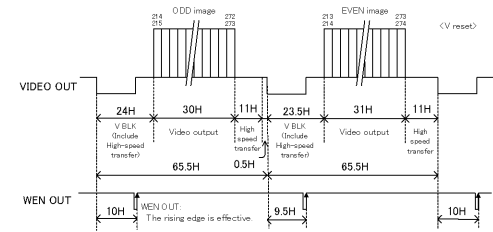

Under other shutter modes

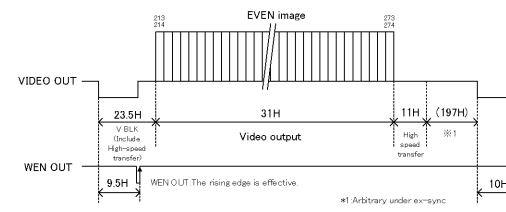
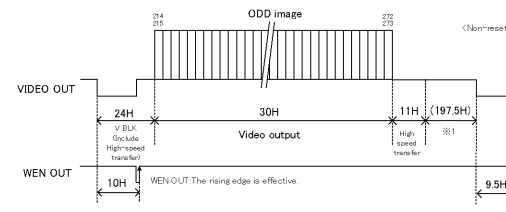

6. SPECIFICATIONS

[Basic spec]

(1) Image sensor	All Pixel's Data Read
Total pixels	692(H) x 504(V)
Active pixel	659(H) x 494(V)
Video output pixels	648(H) x 494(V) (Under non-interlace)
Scanning area	4.88(H) x 3.66(V) mm (= Equivalent to 1/3" type CCD size)
Unit cell size	7.4(H) x 7.4(V) μm (Square-grid array)
(2) Scanning lines	525 lines
(3) TV system	Special format (Non-conforming to EIA/CCIR)

(4) Interlace

1/60s Non-interlace mode

1/120s 2:1 Interlace mode

(5) Sync system

(6) Aspect ratio

(7) Video output

(8) Resolution

(9) S/N

(10) Illumination

(11) Gain

(12) Gamma correction

(13) White-clip level

(14) Power source

(15) Power consumption

[Internal sync spec]

(1) Base clock frequency

(2) H sync frequency

(3) V sync frequency

[External sync spec]

(1) Ext. sync input signal

(2) Input level

(3) Input impedance

(4) Interlace

(5) Polarity

(6) Pulse width

(7) Repeating frequency

(8) Phase difference

[Shutter trigger spec]

(1) Input level

(2) Input impedance

(3) Capture timing

(4) Pulse width

[Sync signal spec]

(1) Polarity

Switching via rear-panel DIP SW
Internal/External automatic switch-over
4:3
VS 1.0V(p-p) / 75 Ω, DC coupled, 1 line
485 TV lines(H)
485 lines (350 TV lines(V))
Standard: 52dB(p-p)/rms (Initial factory setting)
Standard 400 lx (F5.6)
Minimum 4 lx (F1.4) (GAIN MAX, Approx. 50 % video output)
FIX (Fixed) gain: Factory-shipped preset level
MANU (Manual) gain: Setting through GAIN VR
FIX / MANU switching via rear-panel DIP SW
Gamma = 1 (Fixed)
Approx. 840mV(p-p) (Excluding SYNC)
DC12V ±10 %
Ripple voltage: 50mV(p-p) or less
Approx. 1.8W

24.545MHz (1CLK) ± 200ppm

31.468kHz (1H = 780CLK)

59.94Hz (Under non-interlace)

119.88Hz (Under 2:1 interlace)

HD/VD

2~4V (p-p) 10kΩ

75Ω / High impedance (switching via rear-panel SW)

(Initial factory setting: High)

1/60s non-interlace or 1/120s 2:1 interlace

Negative

HD: 3.2 ± 1 μs (LOW)

VD: From 125 through 400 μs (LOW)

f_H = 31.468kHz ± 1%

f_V = f_H/262.5 or f_H/525

HD/VD: 0 ± 5.0 μs, 1/FH/2 ± 5.0 μs

Exposure timing-cue signal in random trigger shutter mode

LOW level: 0~0.5V(p-p)

HIGH level: 4~5V(p-p)

High impedance (10kΩ)

Rising edge detection (Positive) / Falling edge detection (Negative)

(Switching via rear-panel DIP SW)

(Initial factory setting: Rising edge)

Minimum 2 μs

Maximum 1/8s

WEN readout timing signal

Rising edge

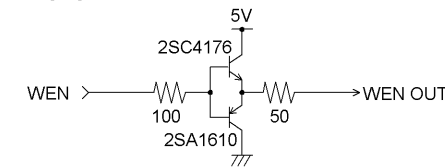

[Electronic shutter spec]

(1) Normal shutter

(2) RTS

(a) Operation mode

Shutter-speed setting via rear-panel SW (Initial: OFF)

Selection among 8 scales (= OFF, 1/200s, 1/500s, 1/1000s, 1/2000s, 1/4000s, 1/8000s, 1/20000s)

No.	Reset	Exposure	Sync
1	Non-reset	Rear SW (FIX mode)	Internal
2		Consecutive HD / Consecutive VD IN	Internal
3		Consecutive HD / Single VD IN	Internal
4	V-reset	TRIG pulse width (PULSE mode)	Internal
5		Consecutive HD / Consecutive VD IN	Internal
6		Consecutive HD / Single VD IN	Internal
7	V reset	Rear SW (FIX mode)	Internal
8		Consecutive HD IN	Internal
9		SYNC reset	Internal
10	V reset	TRIG pulse width (PULSE mode)	Internal
11		Consecutive HD IN	Internal

*RTS shutter mode automatically switches over through TRIG IN

**RTS disabled under electronic shutter OFF

(b) Multiple shutter

(3) Restart / Reset

Multiple shutter via ext. trigger signal and ext. VD signal

*Operation like No.3, 6 above

Restart / reset available via ext. VD signal

(Switching via rear panel DIP SW, Initial OFF)

Notes:

*The exposure-time (shutter-speed) is determined by ext. VD interval.

**Enabled when rear-panel DIP SW OFF.

***Provide Consecutive HD.

[Mechanical spec]

(1) External dimension

(2) Weight

(3) Lens mount

(4) GND / insulation

[Ambient condition]

(1) Environment condition

Performance guaranteed

Operation guaranteed

Storage

(2) EMC conditions (Electro-Magnetic Compatibility)

EMI (Electro-Magnetic Interference)

EMS (Electro-Magnetic Susceptibility)

*Conformity of EMC conditions

About the conformity of the EMC standard of this machines, it has guaranteed in the conditions combined with the option part of 4th clause.

When used combining parts other than specification of our company, I ask you to have final EMC conformity checked of a visitor with a machine and the whole equipment.

[Connector pin assignment]

(1) Compatible connector

(2) Pin assignment

HR10A-10P-12S (Supplied by HIROSE ELEC.)

Pin No.	Signal (Standard)
1	DC12V GND
2	DC12V
3	VIDEO GND
4	VIDEO OUT
5	HD GND
6	HD IN
7	VD IN
8	TRIG GND
9	NC
10	WEN OUT
11	TRIG IN
12	VD GND

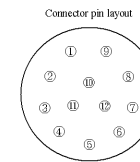

Picture Rear-camera connector (Rear-view)

*Before connecting / disconnecting the connector, make sure the camera power is OFF.

**For board connection, check compatibility.

[Switch setting]

(1) CCU rear-panel DIP SW

No.	Function	OFF	ON
1			
2	E-shutter-speed (SHUT)	See shutter-speed table (Table 1)	
3			
4	Video output mode	1/60s non-interlace	1/120s interlace
5	Shutter mode (SMODE)	See shutter-mode table (Table 3)	
6			
7	Partial scan (PART)	See partial-scan table (Table 2)	
8			
9	TRIG polarity (TRIG)	Positive (Rising edge)	Negative (Falling edge)
10	RTS Exposure (EXP)	FIX mode	PULSE W mode

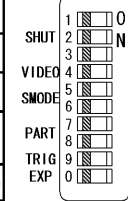

*Initial factory setting: All OFF

**Set No.9 OFF when TRIG IN OPEN.

(Table 1) Electronic shutter-speed

Shutter-speed	No.1	No.2	No.3
OFF	OFF	OFF	OFF
1/200s	ON	OFF	OFF
1/500s	OFF	ON	OFF
1/1000s	ON	ON	OFF
1/2000s	OFF	OFF	ON
1/4000s	ON	OFF	ON
1/8000s	OFF	ON	ON
1/20000s	ON	ON	ON

*Don't set Electronic shutter-speed in OFF under RTS mode.

(Table 2) Partial-scan

Partial scan	No.7	No.8
OFF	OFF	OFF
Not acceptable	ON	OFF
1/2 partial	OFF	ON
1/4 partial	ON	ON

(Table 3) Shutter-mode

Shutter mode	No.5		No.6		SYNC
	V reset	OFF	OFF	OFF	
Random trigger	SYNC reset	ON	OFF	OFF	Internal sync
	Non-reset	OFF	ON	ON	
	Not acceptable	ON	ON	ON	
Random trigger	Non-reset (Multiple shutter)	OFF	OFF	Single VD	Ext. sync HD IN
		ON	OFF	Consecutive VD	
	V-reset	OFF	ON	No VD	
	Restart / Reset	ON	ON	Single VD	

*Under normal shutter mode partial-scan, set No.5, 6 in OFF.

**Under PULSE W mode, SYNC reset is disabled.

Function	SW	Selected Function
Ext. SYNC IN impedance (HD / VD)	HIGH	High impedance (Initial factory setting)
	75Ω	75Ω
GAIN selection (GAIN)	F	Factory-set GAIN
	M	Manual GAIN adjustable via GAIN potentiometer

7. TIMING CHART

(1) H rate timing

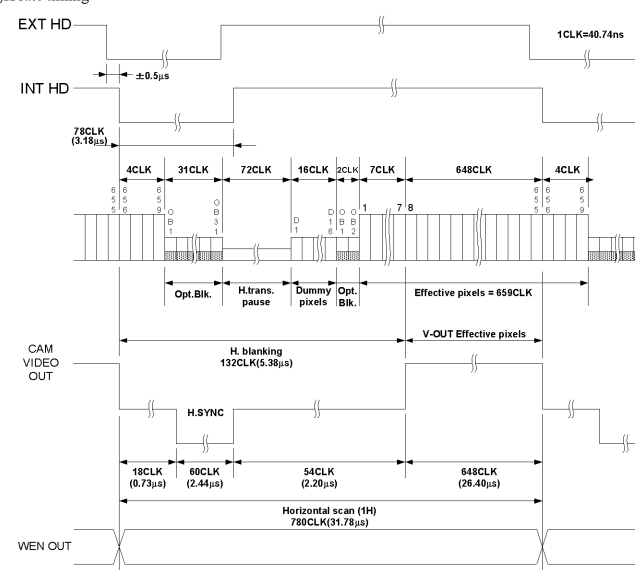

(2) 1/60s Non-interlace mode

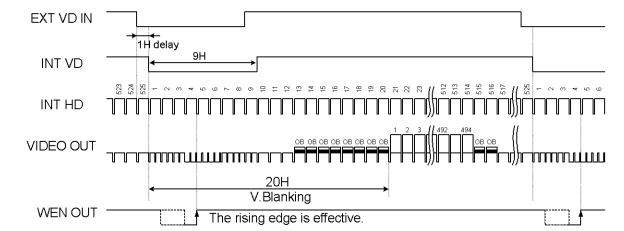

(3) 1/120s 2:1 Interlace mode

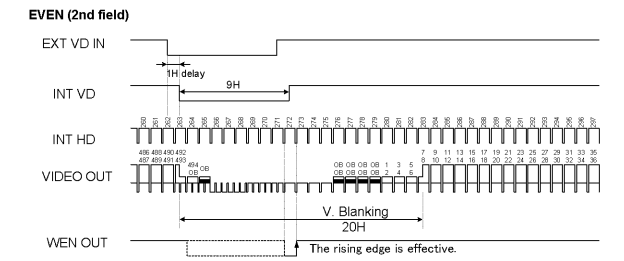
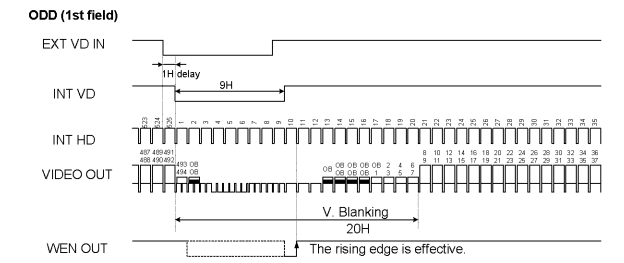

8. EXTERNAL VIEW DRAWING

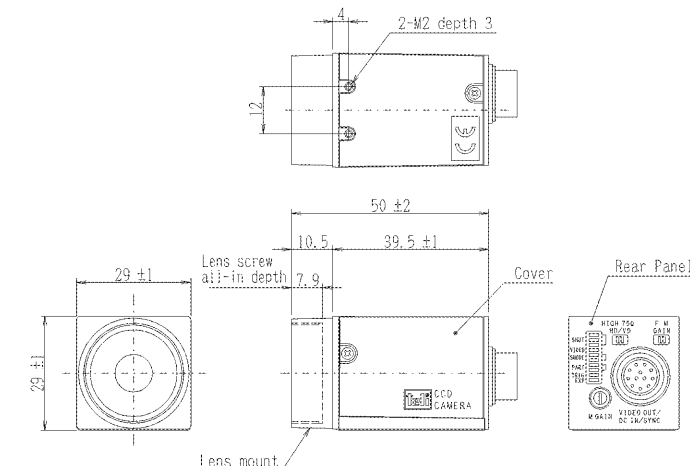

Specification	
Material	Lens-mount, Rear panel: Aluminum die-cast
	Cover : Anticorrosion aluminum alloy
Processing	Lens-mount, Rear panel: Cation coating
	Cover : Leather satin coating (Black)