



CCD Color Camera

GiantDragon Color Series

CSGV90CC3-B CSGX36CC3-B
CSGS20CC2-B CSGU15CC18-B

Specifications

Contents

CASES FOR INDEMNITY (LIMITED WARRANTY)

RESTRICTION FOR USE

Notes on using this product

1. Overview	1
2. Features	1
3. Configuration	2
4. Optional part	2
5. Functions	3
6. Specifications	6
7. Timing chart	16
8. Guarantee	19
9. Repair	19
10. Outline Drawing	20

TOSHIBA TELI CORPORATION

Printed on recycled paper

D4166195E

CASES FOR INDEMNITY (LIMITED WARRANTY)

We shall be exempted from taking responsibility and held harmless for damage or losses incurred by the user in the following cases.

- In the case damage or losses are caused by fire, earthquake, or other acts of God, acts by a third party, deliberate or accidental misuse by the user, or use under extreme operating conditions.
 - In the case of indirect, additional, consequential damages (loss of business interests, suspension of business activities) are incurred as result of malfunction or non-function of the equipment, we shall be exempted from responsibility for such damages.
 - In the case damage or losses are caused by failure to observe the information contained in the instructions in this instruction manual and specifications.
 - In the case damage or losses are caused by use contrary to the instructions in this instruction manual and specifications.
 - In the case damage or losses are caused by malfunction or other problems resulting from use of equipment or software that is not specified.
 - In the case damage or losses are caused by repair or modification conducted by the customer or any unauthorized third party (such as an unauthorized service representative).
 - Expenses we bear on this product shall be limited to the individual price of the product.
-

RESTRICTION FOR USE

- Should the equipment be used in the following conditions or environments, give consideration to safety measures and inform us of such usage:
 1. Use of the equipment in the conditions or environment contrary to those specified, or use outdoors.
 2. Use of the equipment in applications expected to cause potential hazard to people or property, which require special safety measures to be adopted.

 - This product can be used under diverse operating conditions. Determination of applicability of equipment or devices concerned shall be determined after analysis or testing as necessary by the designer of such equipment or devices, or personnel related to the specifications. Such designer or personnel shall assure the performance and safety of the equipment or devices.

 - This product is not designed or manufactured to be used for control of equipment directly concerned with human life (*1) or equipment relating to maintenance of public services/functions involving factors of safety (*2). Therefore, the product shall not be used for such applications.
 - (*1): Equipment directly concerned with human life refers to.
 - Medical equipment such as life-support systems, equipment for operating theaters.
 - Exhaust control equipment for exhaust gases such as toxic fumes or smoke.
 - Equipment mandatory to be installed by various laws and regulations such as the Fire Act or Building Standard Law
 - Equipment related to the above
 - (*2) :Equipment relating to maintenance of public services/functions involving factors of safety refers to.
 - Traffic control systems for air transportation, railways, roads, or marine transportation
 - Equipment for nuclear power generation
 - Equipment related to the above
-

Notes on using this product

- **Handle carefully**

Do not drop the equipment or allow it to be subject to strong impact or vibration, as such action may cause malfunctions. Further, do not damage the connection cable, since this may cause wire breakage.

- **Environmental operating conditions**

Do not use the product in locations where the ambient temperature or humidity exceeds the specifications. Otherwise, image quality may be degraded or internal components may be adversely affected. In particular, do not use the product in areas exposed to direct sunlight. Moreover, during shooting under high temperatures, vertical stripes or white spots (noise) may be produced, depending on the subject or camera conditions (such as increased gain). However, such phenomena are not malfunctions.

- **Regarding a lens mount**

Depending on the lens you use, the performance of the camera may not be brought out fully due to the deterioration in resolution and brightness in the peripheral area, occurrence of a ghost, aberration and others. When you check the combination between the lens and camera, be sure to use the lens you actually use.

As for the C-mount lens used combining this camera, the projection distance from bottom of the screw should use 8.8mm or less.

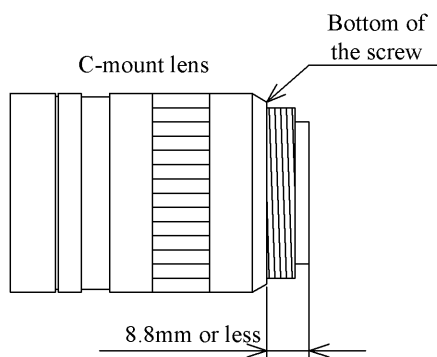

- **Check a combination with the lens**

Depending on the lens and lighting you use, an image is reflected as a ghost in the imaging area. However, this is not because of a fault of the camera.

In addition, depending on the lens you use, the performance of the camera may not be brought out fully due to deterioration in resolution and brightness in the peripheral area, aberration and others.

Be sure to check a combination with the camera by using the lens and lightning you actually use.

When installing a lens in the camera, make sure carefully that it is not tilted.

In addition, use a mounting screw free from defects and dirt. Otherwise, the camera may be unable to be removed.

- **Do not shoot under intense light**

Avoid intense light such as spot lights on part of the screen because it may cause blooming or smears. If intense light falls on the screen, vertical stripes may appear on the screen, but this is not a malfunction.

- **Occurrence of moiré**

If you shoot thin stripe patterns, moiré patterns (interference fringes) may appear. This is not a malfunction.

- **Occurrence of noise on the screen**

If an intense magnetic or electromagnetic field is generated near the camera or connection cable, noise may be generated on the screen. If this occurs, move the camera or the cable.

- **Handling of the protective cap**

If the camera is not in use, attach the lens cap to the camera to protect the image pickup surface.

- **If the equipment is not to be used for a long duration**

Turn off power to the camera for safety.

- **Maintenance**

Turn off power to the equipment and wipe it with a dry cloth.

If it becomes severely contaminated, gently wipe the affected areas with a soft cloth dampened with diluted neutral detergent. Never use alcohol, benzene, thinner, or other chemicals because such chemicals may damage or discolor the paint and indications.

If the image pickup surface becomes dusty, contaminated, or scratched, consult your sales representative.

- **Disposal**

When disposing of the camera, it may be necessary to disassemble it into separate parts, in accordance with the laws and regulations of your country and/or municipality concerning environmental contamination.

1. Overview

This GiantDragon Color series is an integrated-(one-body)-type color camera that adopts all pixel data readout inter line CCD. There are 4 models according to the sensor type. These are CSGV90CC3-B (VGA), CSGX36CC3-B (XGA), CSGS20CC2-B (SXGA) and CSGU15CC18-B (UXGA). For video output and camera control, the Gigabit Ethernet^{®*} interface standard “IEEE802.3ab” is adopted for high transfer rate, and it is easy to integrate into industrial equipment.

*Ethernet[®] is a registered trademark of XEROX Corporation.

2. Features

(1) High frame rate and high resolution

Supported high frame rate CSGV90CC3-B (90fps/VGA), CSGX36CC3-B (36fps/XGA), CSGS20CC2-B (20fps/SXGA) and CSGU15CC18-B (15fps/UXGA).

(2) All pixel readout

All pixel signals (in the effective area) are output in one frame processing.

(3) Full frame shutter

Since all pixels are output even by shutter operation, high resolution can be achieved, without deteriorating the vertical resolution.

(4) Square grids

The CCD pixels arrayed in square grids facilitates computation for image processing.

(5) Color processing

Since color processing is built in, there are also RGB (24bit), YUV 4:2:2 (16bit), YUV 4:1:1 (12bit) output modes besides Raw output mode (8/10bit).

(6) Gigabit Ethernet interface

Performs video output and camera control via the Gigabit Ethernet standard IEEE802.3ab interface. Data transfer is at 1Gbps (Maximum) that can output uncompressed video data of high frame rate.

(7) GigEVision Ver 1.0 conformity

This product is based on GigEVision Camera Interface Standard for Machine Vision Ver 1.0 that is industrial camera standard. Therefore, control of this camera is easy.

(8) GenICam Ver 1.0 conformity

This product is based on GenICam Generic Interface for Cameras Ver 1.0 that is industrial camera standard. Therefore, control of this camera is easy.

(9) High-speed draft readout mode

By thinning out vertical lines, it can be read all effective area at high-speed frame rate.

(10) Random trigger shutter

The random trigger shutter function provides images in any timing by input of an external trigger signal. Trigger control from PC is possible.

(11) Scalable

Selectable video output area. It can be higher frame rate by reducing vertical output area. And can be reduce occupied data rate of Gigabit Ethernet by reducing horizontal output area.

(12) Compact and lightweight

This camera is compact and lightweight, and it is easy to integrate into industrial equipment.

(13) EU RoHS & Chinese ROHS compliant

3. Configuration

(1) Camera body	1
(2) Accessories		
- Instruction Manual (Japanese)	1
- Instruction Manual (English)	1
* No application software is attached to this camera.		

4. Optional part

- Camera mounting kit Model name: CPT8420

* Contact your dealer / distributor for details of option units.

5. Functions

(1) Setup-level setting

You can set the pedestal in 192 steps in the range between 6.3 and 25%.

(2) Gain setting

There is AGC (Auto Gain Control) other than manual setting, too. Setting range and effective range are 0 to +6dB.

(3) White balance

There are two types of white balancing mode, MWB (Manual White Balance) and OPWB (One Push White Balance). You can set white balancing mode, according to the subject and purpose.

(4) Gamma correction

You can set gamma correction Table1: Gamma = 0.65 / Table0: Gamma = 1.0.

* The user cannot adjust the correction amount.

(5) Masking correction

The hue of images is masking corrected so that it will be natural (ON fixed).

* The user cannot adjust the correction amount.

(6) High-speed draft readout mode

By thinning out vertical lines, it can be read all effective area at high-speed frame rate.

* As for CSGV90CC3-B (VGA), this mode supports a fault.

	CSGV90CC3-B	CSGX36CC3-B	CSGS20CC2-B	CSGU15CC18-B
Draft mode		1/3	1/2	1/4
Readout vertical line number		254	480	300
Maximum frame rate		86 fps	34fps	46fps

(7) Image resending control

As the resending control of the image, this camera resends the packet which suffered a loss.

(8) Event packet sending function

As the function that sends the event packet, this camera sends EVENT_CMD packet, when the external trigger signal is input to this camera.

(10) Scalable mode

This camera has the scalable mode that can read out defined area of the screen. Only continuous rectangle units can be selected, concave or convex shape cannot be selected.

- Window size: $\{A \times m(H)\} \times \{B \times n(V)\}$

* A and B are minimum unit size.

* m, n = integer, and the image of maximum unit size or less can be selected.

* Only one window can be selected.

	CSGV90CC3-B	CSGX36CC3-B	CSGS20CC2-B	CSGU15CC18-B
Minimum unit size (H) x (V)	160 x 120	256 x 192	160 x 120	200 x 150
Maximum unit size (H) x (V)	640 x 480	1024 x 768	1280 x 960	1600 x 1200

- Start address: $\{32 \times i(H)\} \times \{24 \times j(V)\}$

* i, j = integer, and the image of maximum unit size or less can be selected.

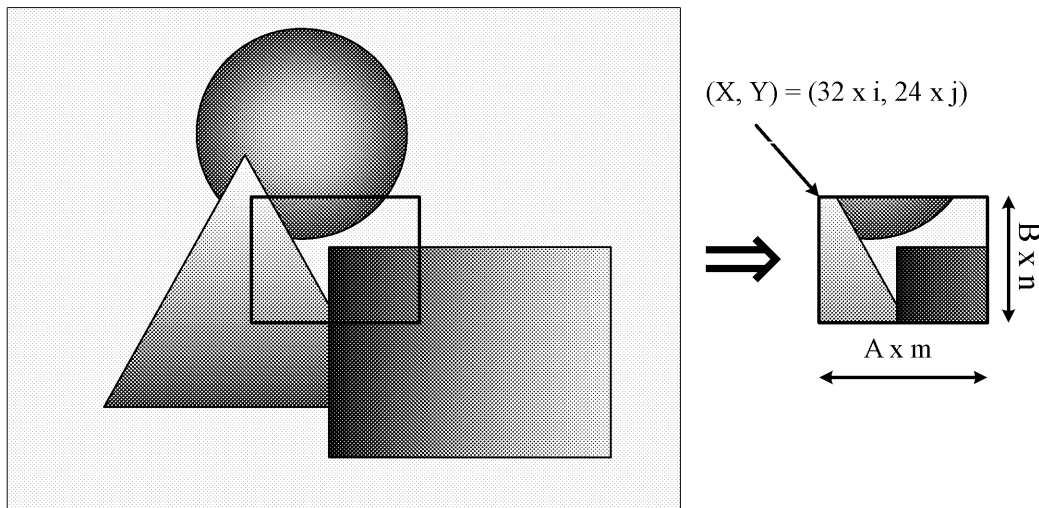

In the scalable mode, this camera reads out only the necessary portions at the standard speed while it scans through other unnecessary portions at high speed, so the trigger interval can be shorter if the vertical cutout width is small. However, the trigger interval cannot be short in the horizontal direction even if the cutout width is small due to the operation mechanism of the CCD sensor.

Notes on scalable mode:

- White lines may occur in the upper portions of the screen when strong light exists in a wide area during the scalable mode. This is not a malfunction. If white lines occur, adjust the amount of incident light using the lens.

6. Specifications

[Electrical specification]

(1) Imager

all-pixel-data-readout interline transfer CCD

	CSGV90CC3-B	CSGX36CC3-B	CSGS20CC2-B	CSGU15CC18-B
Number of total pixels (H) x (V)	692 x 504	1077 x 788	1434 x 1050	1688 x 1248
Number of effective pixels (H) x (V)	659 x 494	1034 x 779	1392 x 1040	1628 x 1236
Number of Video out pixels (H) x (V)	640 x 480	1024 x 768	1280 x 960	1600 x 1200
Scanning area (H) x (V)	4.88 x 3.66mm ² (1/3 type)	4.81 x 3.62mm ² (1/3 type)	6.47 x 4.84mm ² (1/2 type)	7.16 x 5.44mm ² (1/1.8 type)
Pixel size (H) x (V)	7.4 x 7.4μm ²	4.65 x 4.65μm ²	4.65 x 4.65μm ²	4.40 x 4.40μm ²
Color filter	RGB primary color mosaic-on-tip color filter			

(2) Scan method

Non-interlace

(3) Synchronization method

Internal synchronization

(4) Aspect ratio

4: 3

(5) Sensitivity

	CSGV90CC3-B	CSGX36CC3-B	CSGS20CC2-B	CSGU15CC18-B
Standard subject illuminance	1700 lx F5.6 5000K 1/90s	2400 lx F5.6 5000K 1/36s	1400 lx F5.6 5000K 1/20s	1000 lx F8 5000K 1/15s

(6) Minimum subject illuminance (F1.4, GAIN Maximum, video level 50 %, Gamma ON)

	CSGV90CC3-B	CSGX36CC3-B	CSGS20CC2-B	CSGU15CC18-B
Minimum subject illuminance	20 lx	27 lx	18 lx	7 lx

- (7) Gain AGC/Manual switching (initial factory setting :Manual)
- AGC (Auto Gain Control)
 - Effective range 0 to +6dB
 - Effective area Full screen
 - * When the random shutter is active, AGC function is disabled.
 - * When Raw output mode (8/10bit), AGC function is disabled.
- Manual setting
- Setting range 0 to +6 dB (38 step, initial factory setting: 0 dB)

Notes on gain setting:

Setting the gain value too high increases noises. When adjust the brightness of the image, I ask you to have final image checked of a visitor with a machine and the whole equipment.

- (8) Gamma correction Table1 (Gamma = 0.65) / Table0 (Gamma = 1.0) switching
initial factory setting: Table1
- * When Raw output mode(8/10bit),
Gamma correction function is disabled (Table0 fixed).
- (9) Masking correction ON fixed
- * When Raw output mode(8/10bit),
Masking correction function is disabled (OFF fixed).
- (10) White balance OPWB/MWB switching (initial factory setting: MWB)
- OPWB (One Push White Balance)
 - Effective range 2500 K to 6500 K
 - Effective area Full screen
 - * When the random shutter is active, OPWB function is disabled.
 - * When Raw output mode (8/10bit), OPWB function is disabled.
- MWB (Manual White Balance)
- Setting range 2500 K to 6500 K
 - Setting method R-gain and B-gain can be set independently.
 - * When Raw output mode (8/10bit), MWB setting is disabled.

- (11) Setup-level 6.3 to 25 % (192step)
initial factory setting: 6.3% [Approximately 16digit/8bit]
- (12) Power supply DC 12V +/-10% (ripple 100 mV(p-p) or less)
- (13) Power consumption 3.5W (Maximum)

[Internal sync signal specification]

- (1) Base clock frequency 36.0000 MHz +/- 100ppm

[Trigger signal specification]

- (1) External trigger input
 - Input level Low level: 0 to 0.5V
High level: 3.3 to 24V (+/-10%)
 - Polarity Positive/Negative bipolar (initial factory setting: Negative)
 - Pulse width Minimum 50μs (Refer to 7. Timing chart.)
 - External trigger input circuit Photo coupler input

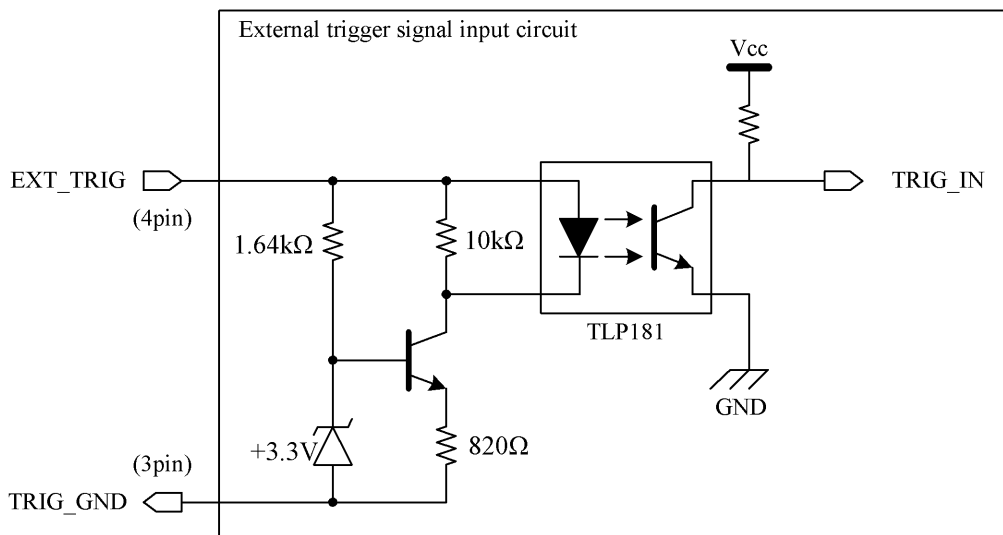

* When drive current value of the external trigger signal is too low, this camera may not receive the trigger signal.

- (2) Software trigger Set via the Gigabit Ethernet interface

[Optical axis accuracy]

	Position accuracy of effective pixels		Rotation accuracy of effective pixels(θ)	Flange focal distances (Flange back) (for 17.526mm)
	(X)	(Y)		
Optical axis accuracy	$\pm 25\mu\text{m}$	$\pm 25\mu\text{m}$	$\pm 0.12^\circ$	$\pm 50\mu\text{m}$

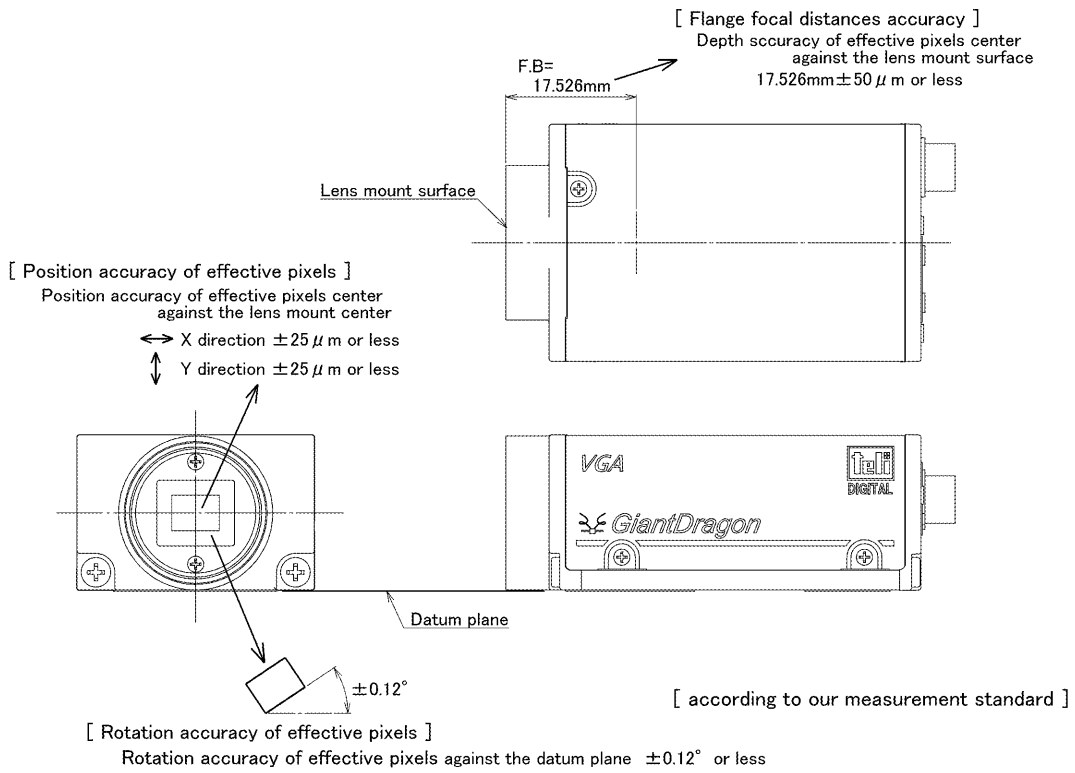

[Operating ambient conditions]

(1) Ambient conditions

- Performance assurance Temperature: 0 to +40°C, Humidity: 10 to 90% (no condensation)
- Operating assurance Temperature: -5 to +45°C, Humidity: 90% or less (no condensation)
- Storage assurance Temperature: -20 to +60°C, Humidity: 90% or less (no condensation)

(2) EMC conditions (Electro-Magnetic Compatibility)

- EMI (Electro-Magnetic interference)

EN61000-6-4 conformity

FCC part15 Subpart B class A conformity

- EMS(Electro-Magnetic susceptibility)

EN61000-6-2 conformity

Notes on Conformity of the EMC:

The adaptability of the safety standard of this camera is assured in the condition of combination with the following parts:

- AC Adapter CA130D (for 100V 50/60Hz)
- DC Cable CPC3910-03
- LAN Cable C5e(S-HFR)(K)-5 (Manufactured by Oki Electric Cable Co., Ltd.)

Please confirm the EMC adaptability when it combines with parts other than them.

[Connector pin assignment]

(1) Gigabit Ethernet interface connector

- Connector model (Camera side) P65-P01-19V8 (Supplied by SpeedTech Corp.)
- Pin assignment

Pin No.	I/O	Function
1	I/O	BI_DA+
2	I/O	BI_DA-
3	I/O	BI_DB+
4	I/O	BI_DC+
5	I/O	BI_DC-
6	I/O	BI_DB-
7	I/O	BI_DD+
8	I/O	BI_DD-

(2) Connector for Power Supply and trigger signal input

- Connector (Camera side) HR10A-7R-6PB(73)
(Supplied by HIROSE ELECTRIC CO., LTD.)

- Plug (Cable side) HR10A-7P-6S(73)
(Supplied by HIROSE ELECTRIC CO., LTD.)

* This camera cable is not an accessory of this product.

- Pin assignment

Pin No.	Signal Name [Standard specification]
1	BUSY_OUT
2	GND
3	TRIG_GND
4	EXT_TRIG
5	EXPOSE_OUT
6	+12V

Pin number assignment

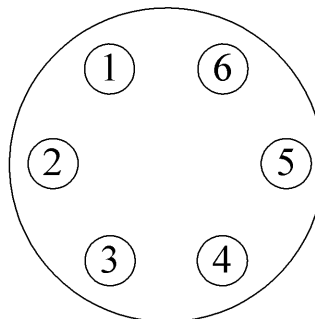

*Above figure is connector view from insert side.

[Typical spectral response]

The lens characteristics and light source characteristics is not reflected in table.

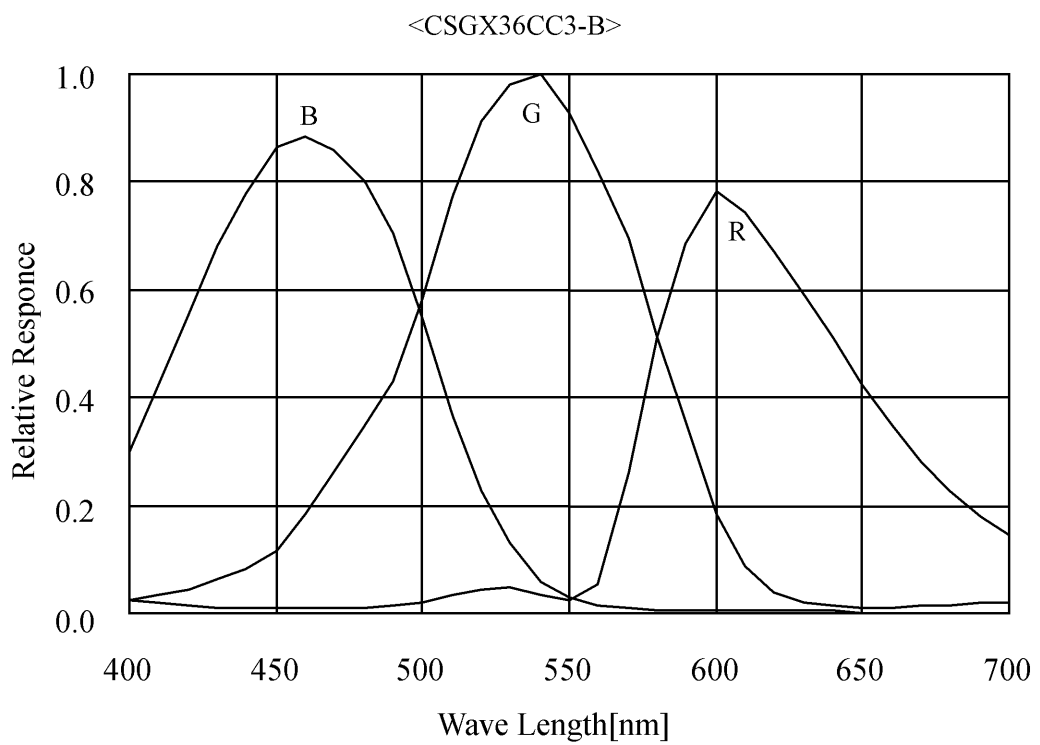
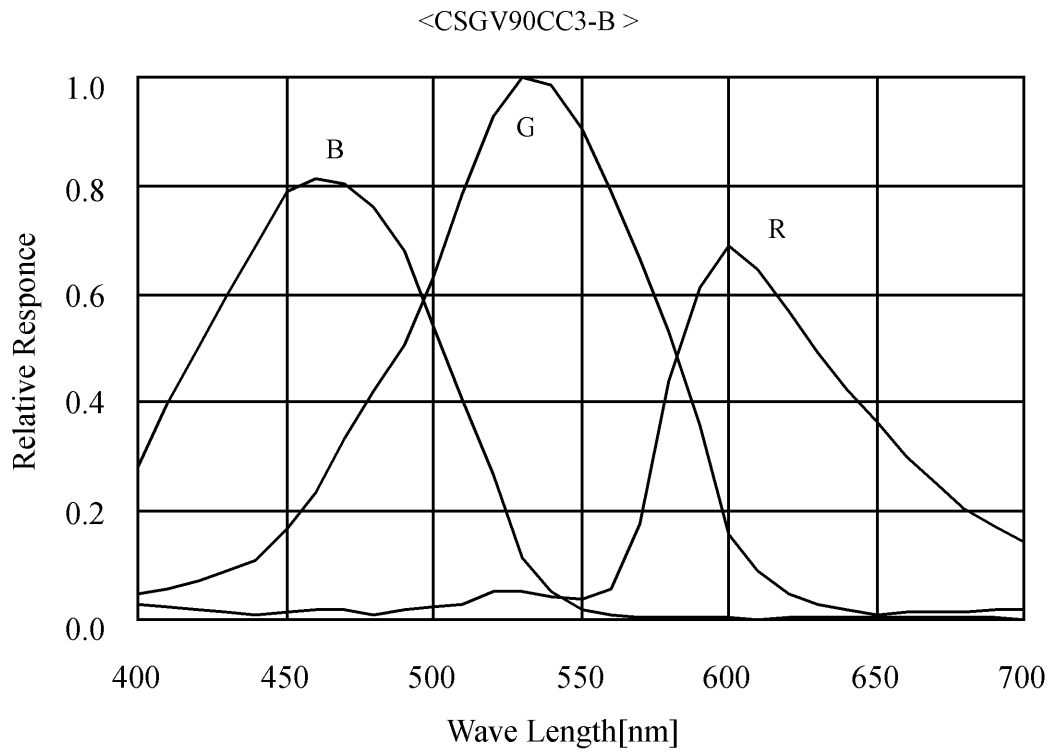

<CSGS20CC2-B>

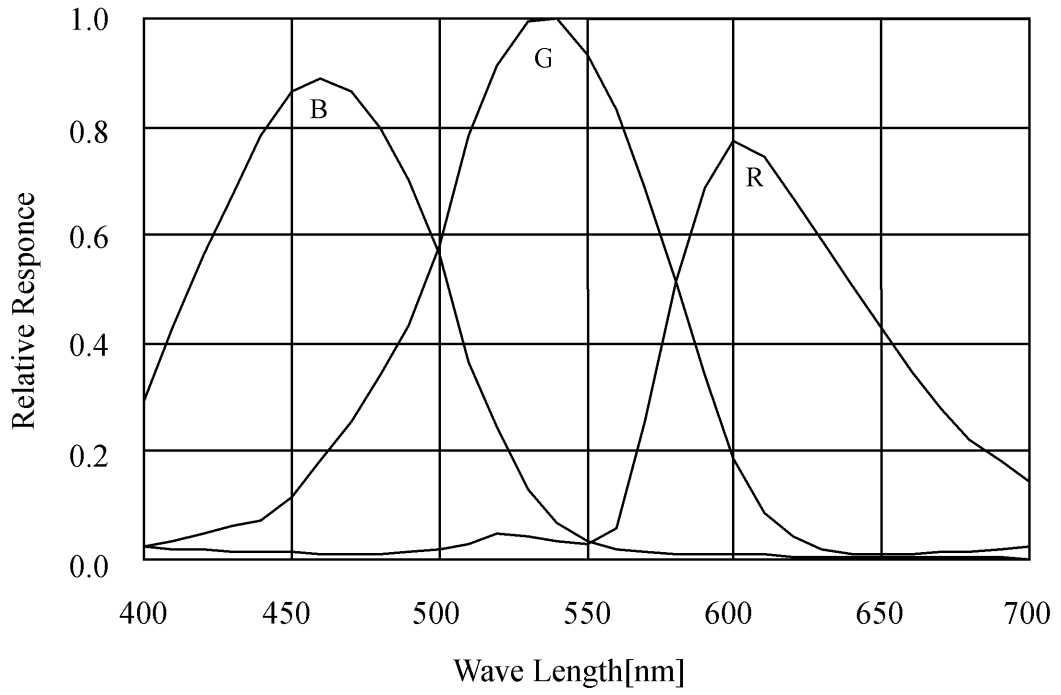

<CSGU15CC18-B>

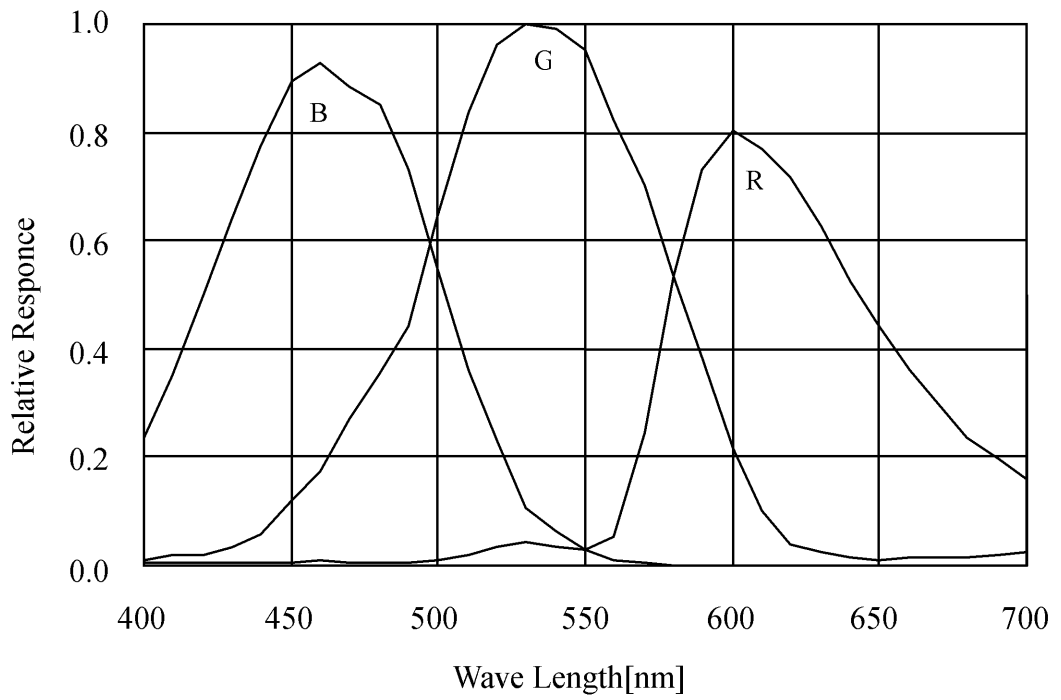

7. Timing chart

Image data outputs of this camera series are transferred with the UDP protocol of Gigabit Ethernet. Timing numerical value below is prescribed by absolute prerequisite that GiantDragon series use transmission band without restriction of other node. When there is a node transferring with GiantDragon concerned, it is not same the numerical value prescribed below.

(1) In the normal shutter mode

Video format: RGB 24 bit, all pixel readout

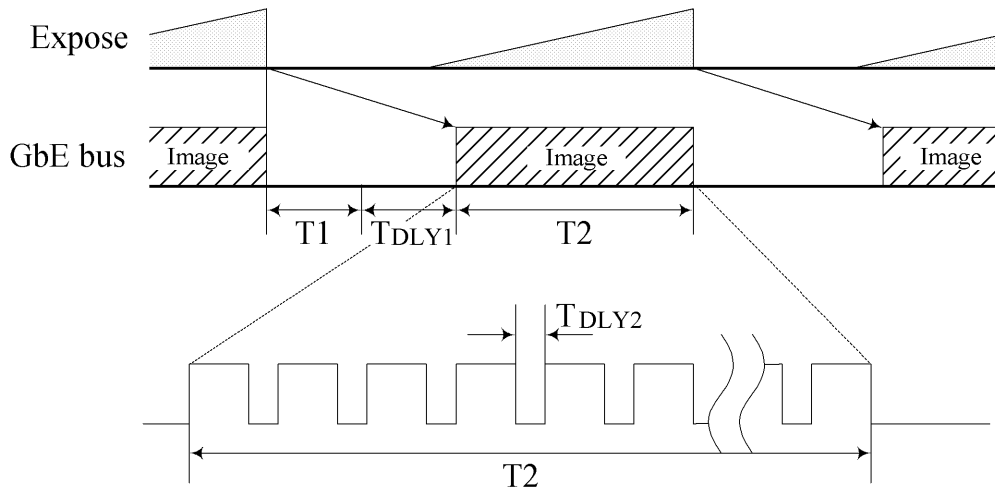

Model name	T1 [ms]	T2 [ms]	Frame rate [ms]
CSGV90CC3-B	*1	*2	11.1
CSGX36CC3-B			27.8
CSGS20CC2-B			50.0
CSGU15CC18-B			66.7

*1 Because this camera calculates T1 automatically, refer to the following formula.

*2 Because this camera calculates T2 automatically, T2 is same as the Frame rate.

* Frame rate is the default value.

* T1: GVSP_BLOCK_DELAY_OFFSET, T_{DLY1}: GVSP_BLOCK_START_DELAY

T2: GVSP_FRAME_RATE, T_{DLY2}: SCPD

$$* T_1 = (T_2 / (\frac{PayloadSize}{SCPS} - 36)) \times 3$$

* T1 = 100μs or longer.

* At the setting the GVSP_SIZE (SCPSx) = 1500 byte / packet.

(T1 is changed by GVSP_SIZE (SCPSx).)

(2) In the random trigger shutter mode

- When fixed mode (Video format: RGB 24 bit, all pixel readout);

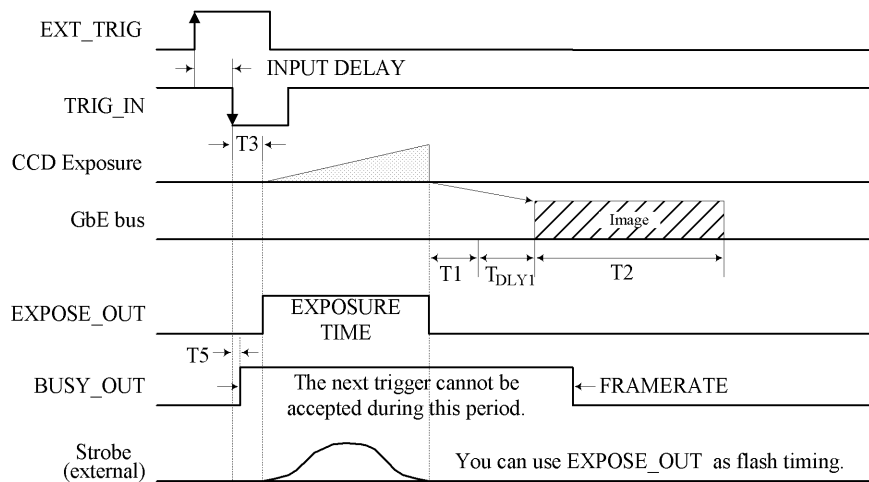

- When pulse width mode (Video format: RGB 24 bit, all pixel readout);

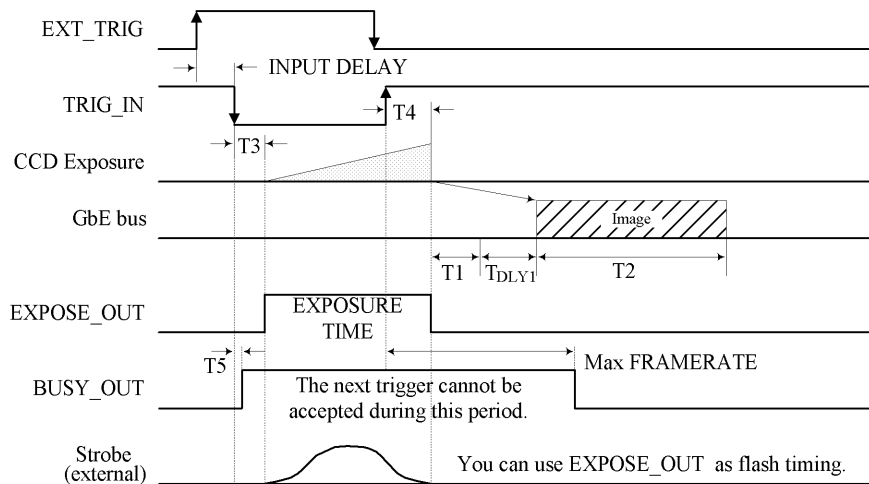

Model name	T3 [μ s]	T4 [μ s]	T5 [ns]
CSGV90CC3-B	0.9	2.8	440
CSGX36CC3-B	1.5	25.2	
CSGS20CC2-B	0.7	5.1	
CSGU15CC18-B	1.9	7.5	

* The value of T1 and T2 are the same as the value at the of the normal shutter setting.

* T3, T4 and T5 are typical value.

Notes of random trigger shutter mode:

- In the period when BUSY_OUT signal is high, user must not input external trigger signal to this camera.
- When the interval of the input trigger signal is extremely short, or when the trigger signal is noisy, there is a possibility of causing the malfunction. In this case, please input a proper trigger signal.

- About the external trigger signal input ;

The specifications of external trigger input signal are as follows;

- Trigger amplitude: +3.3 to +24V (+/- 10%)
- Pulse width: Minimum 50μs

The pulse width of the trigger signal which is received inside of the camera delays to the external trigger signal.

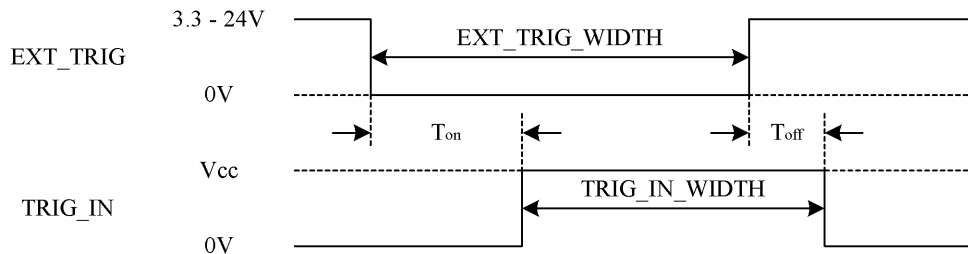

(a) Negative trigger

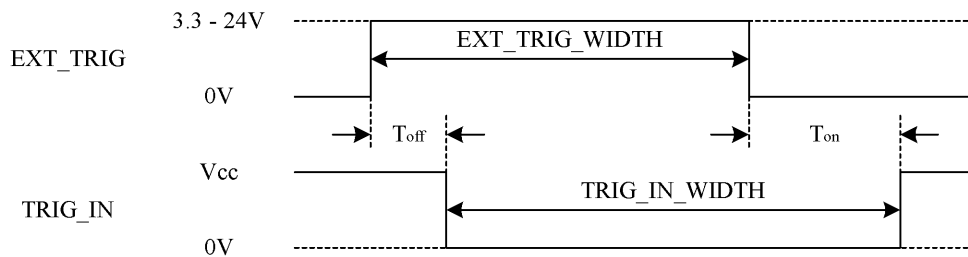

(b) Positive trigger

EXT_TRIG_WIDTH: The pulse width of the external trigger input (more than 50μs).

T_{off}: The delay time of falling edge.

T_{on}: The delay time of rising edge.

TRIG_IN_WIDTH: The pulse width of the trigger signal which is received inside of the camera.

- Negative trigger: $TRIG_IN_WIDTH = EXT_TRIG_WIDTH - (T_{on} - T_{off})$
- Positive trigger: $TRIG_IN_WIDTH = EXT_TRIG_WIDTH + (T_{on} - T_{off})$

Trigger amplitude	T _{off}	T _{on}
+3.3V	About 6 μs	About 15 μs
+24V	About 3 μs	About 25 μs

* T_{off} and T_{on} are typical value.

* These values are changed in operating environment.

8. Guarantee

The term of a guarantee is 12 months after the product delivery.

If by any chance trouble by responsibility of our company occurs before an above period, TELI repairs it free of charge according to a repair rule of Clause 9.

During terms of a guarantee, when the trouble cause is the case of below, TELI charges the repair costs.

- Troubles and the damages that causes by misuse, unsuitable repair or remodeling.
- Distribution hazards like drops and vibrations after purchase. Troubles and damages by transportation.
- Troubles and damages by fire, natural calamity (earthquake, storm and flood damage, thunderbolt), damages from salty breeze, gas harm, abnormal voltage.

9. Repair

(1) Condition for repair

Basically, has to return it to our company when the user requests us to repair product.

Beside that, customer should pay these expenses (travel expenses, camera disassembly technology costs) of both customer and end user. Also customer should pay in themselves costs for return camera to us.

(2) The period of repairing product

- Repair free of charge Refer to Clause 8.
- Charged repair Basically, repair period is 7 years after the last production end of products.

10. Outline Drawing

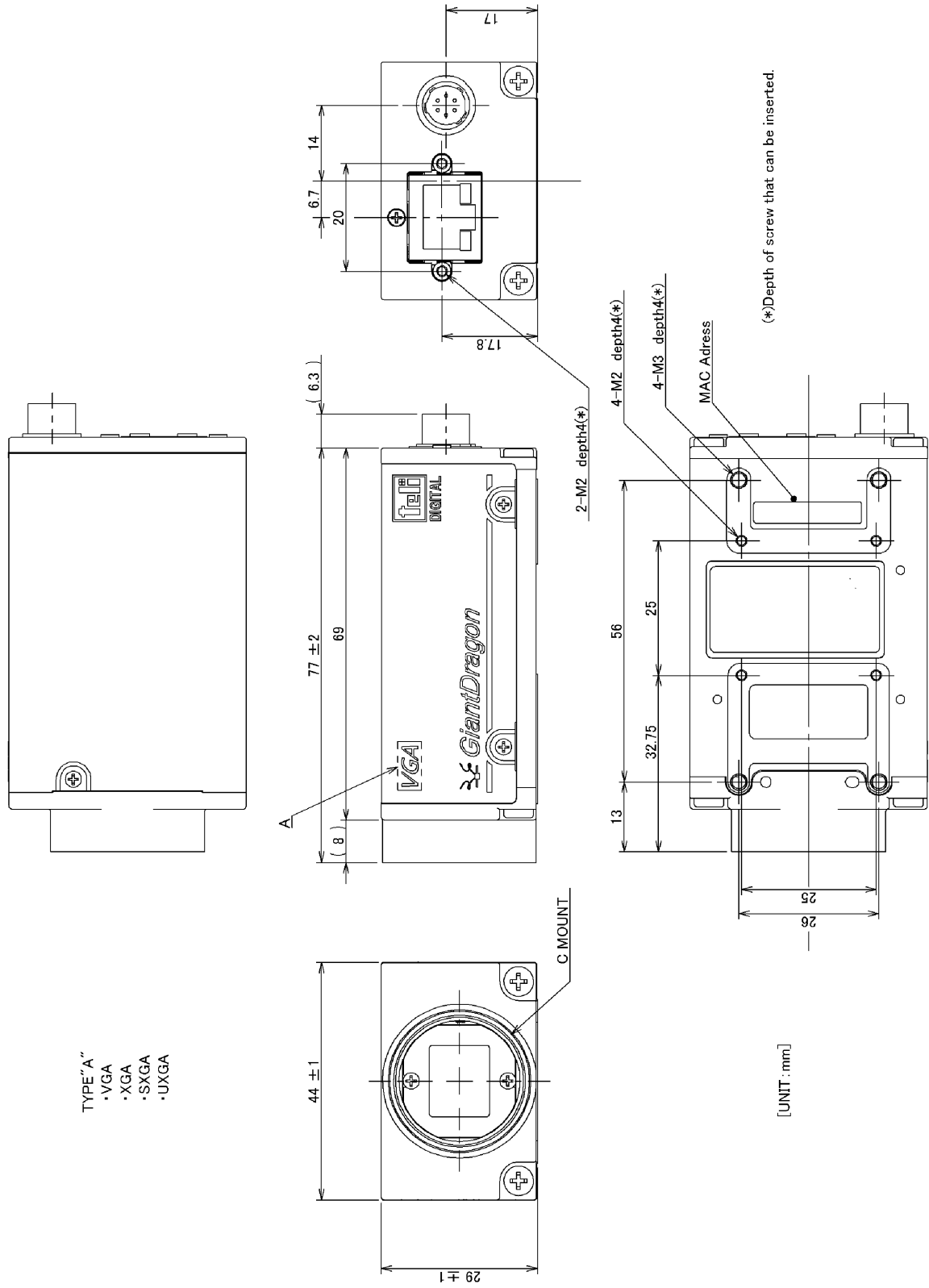



TOSHIBA TELI CORPORATION

Head Office: 7-1, 4 chome, Asahigaoka, Hino-shi, Tokyo, 191-0065, Japan
(International Business Department)

Phone : +81-42-589-8771

Fax : +81-42-589-8774

URL : <http://www.toshiba-teli.co.jp/>

Distributor

- This product must be classified for disposal according to the laws of each country and municipal laws.
 - Information contained in this document is subject to change without prior notice.
-