

# **CMOS Camera BG Series**

**BG040M  
BG040MCG/BG040MCF  
BG160M  
BG160MCG/BG160MCF**

## **Specifications**

# **Toshiba Teli Corporation**

Information contained in this document is subject to change without prior notice.

Standard name might be trade mark of each company.

## Contents

RESTRICTION FOR USE .....	1
CASES FOR INDEMNITY (LIMITED WARRANTY) .....	2
USAGE PRECAUTIONS .....	3
1 Overview .....	5
2 Features .....	5
3 Configuration .....	7
4 Optional part .....	7
5 Functions.....	8
6 Specifications .....	18
7 Timing chart .....	30
8 Warranty rules .....	34
9 Repair.....	35
10 Outline Drawing.....	36

## RESTRICTION FOR USE

- Should the equipment be used in the following conditions or environments, give consideration to safety measures and inform us of such usage:
  - (1) Use of the equipment in the conditions or environment contrary to those specified, or use outdoors.
  - (2) Use of the equipment in applications expected to cause potential hazard to people or property, which require special safety measures to be adopted.
- This product can be used under diverse operating conditions. Determination of applicability of equipment or devices concerned shall be determined after analysis or testing as necessary by the designer of such equipment or devices, or personnel related to the specifications. Such designer or personnel shall assure the performance and safety of the equipment or devices.
- This product is not designed or manufactured to be used for control of equipment directly concerned with human life (\*1) or equipment relating to maintenance of public services/functions involving factors of safety (\*2). Therefore, the product shall not be used for such applications.
  - (\*1): Equipment directly concerned with human life refers to.
    - Medical equipment such as life-support systems, equipment for operating theaters.
    - Exhaust control equipment for exhaust gases such as toxic fumes or smoke.
    - Equipment mandatory to be installed by various laws and regulations such as the Fire Act or Building Standard Law
    - Equipment related to the above
  - (\*2): Equipment relating to maintenance of public services/functions involving factors of safety refers to.
    - Traffic control systems for air transportation, railways, roads, or marine transportation
    - Equipment for nuclear power generation
    - Equipment related to the above

## CASES FOR INDEMNITY (LIMITED WARRANTY)

We shall be exempted from taking responsibility and held harmless for damage or losses incurred by the user in the following cases.

- Natural disasters, such as an earthquake and thunder, fire or any other act of God; acts by third parties; misuse by the user, whether intentional or accidental; use under extreme operating conditions.
- In the case of indirect, additional, consequential damages (loss of business interests, suspension of business activities) are incurred as result of malfunction or non-function of the equipment, we shall be exempted from responsibility for such damages.
- In the case damage or losses are caused by failure to observe the information contained in the instructions in this instruction manual and specifications.
- In the case damage or losses are caused by use contrary to the instructions in this instruction manual and specifications.
- In the case damage or losses are caused by malfunction or other problems resulting from use of equipment or software that is not specified.
- In the case damage or losses are caused by repair or modification conducted by the customer or any unauthorized third party (such as an unauthorized service representative).
- Expenses we bear on this product shall be limited to the individual price of the product.
- The item that is not described in specifications of this product is off the subject of the guarantee.
- The attachment mistake of a cable.

## USAGE PRECAUTIONS

### ● Handle carefully

Do not drop the equipment or allow it to be subject to strong impact or vibration, as such action may cause malfunctions. Further, do not damage the connection cable, since this may cause wire breakage.

If your camera is used in a system where its connector is subjected to strong repetitive shocks, its connector is possible to break down. If you intend to use your camera in such a situation, if possible, bundle and fix a cable in the place near the camera, and do not transmit a shock to the connector.

### ● Environmental operating conditions

Do not use the product in locations where the ambient temperature or humidity exceeds the specifications.

Otherwise, image quality may be degraded or internal components may be adversely affected. In particular, do not use the product in areas exposed to direct sunlight.

### ● Combination of C-mount lens

Depending on the lens you use, the performance of the camera may not be brought out fully due to the deterioration in resolution and brightness in the peripheral area, occurrence of a ghost, aberration and others. When you check the combination between the lens and camera, be sure to use the lens you actually use.

When installing a lens in the camera, make sure carefully that it is not tilted.

In addition, use a mounting screw free from defects and dirt. Otherwise, the camera may be unable to be removed.

As for the C-mount lens used combining this product, the projection distance from bottom of the screw should use 10mm or less.

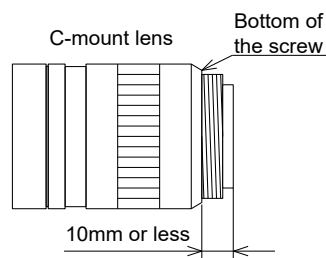

### ● Mounting to a pedestal

When mounting this product to a pedestal, make sure carefully that the lens doesn't touch with the pedestal.

### ● Do not expose the camera's image-pickup-plane to sunlight or other intense light directly.

Its inner CMOS sensor might be damaged.

### ● Occurrence of moiré

If you shoot thin stripe patterns, moiré patterns (interference fringes) may appear. This is not a malfunction.

## USAGE PRECAUTIONS

- **Occurrence of noise on the screen**

If an intense magnetic or electromagnetic field is generated near the camera or connection cable, noise may be generated on the screen. If this occurs, move the camera or the cable.

- **Handling of the protective cap**

If the camera is not in use, attach the lens cap to the camera to protect the image pickup surface.

- **If the equipment is not to be used for a long duration**

Turn off power to the camera for safety.

- **Maintenance**

Turn off power to the equipment and wipe it with a dry cloth.

If it becomes severely contaminated, gently wipe the affected areas with a soft cloth dampened with diluted neutral detergent. Never use alcohol, benzene, thinner, or other chemicals because such chemicals may damage or discolor the paint and indications.

If the image pickup surface becomes dusty, contaminated, or scratched, consult your sales representative.

- **Disposal**

When disposing of the camera, it may be necessary to disassemble it into separate parts, in accordance with the laws and regulations of your country and/or municipality concerning environmental contamination.

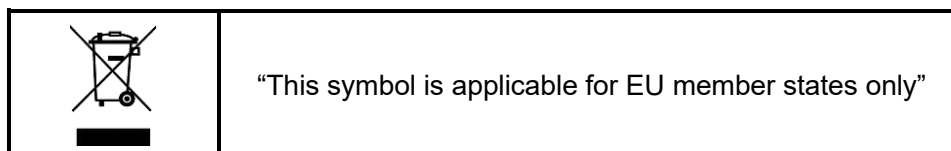

### [Phenomena specific to CMOS sensor]

- **Defective pixels**

A CMOS image sensor is composed of photo sensor pixels in a square grid array. Due to the characteristics of CMOS image sensors, over- or under-driving of the pixels results in temporary white or black areas (as if these are noises) appearing on the screen. This phenomenon, which is not a defect is exacerbated under higher temperatures and long exposure time.

- **Image shading**

The brightness of the upper part of the screen may be different from that of the lower part. Note that this is a characteristic of a CMOS image sensor and is not a fault.

## 1 Overview

This BG series is an integrated-(one-body)-type camera that adopts a global shutter CMOS sensor. These are BG040M (0.4M 1/2.9 type), BG160M (1.6M 1/2.9 type).

Suffix [CG] or [CF] are attached to the color models.

For video output and camera control, the Gigabit Ethernet® interface standard "IEEE802.3ab" is adopted for high transfer rate, and it is easy to integrate into industrial equipment.

## 2 Features

### 2.1 High frame rate and high resolution

Supporting high frame rate, BG040M 291fps, BG160M 72fps.

### 2.2 Global shutter

As it employs a global electronic shutter similar to a CCD image sensor, clear images of even fast-moving object are obtainable with less blur.

### 2.3 Gigabit Ethernet interface (Power over Ethernet)

Video output and camera control are performed via the Gigabit Ethernet standard IEEE802.3ab interface. Data transfer is up to 1Gbps (Maximum) that enables to output uncompressed video data at high frame rate. By complying with IEEE802.3af Power over Ethernet (PoE), the power is supplied over single cable.

### 2.4 GigEVision Ver 1.2

This product is based on GigEVision Camera Interface Standard for Machine Vision Ver 1.2.

### 2.5 GenICam Ver 2.4, Ver 3.0 conformity

This product is based on GenICam (Generic Interface for Cameras) Ver 2.4 and Ver.3.0.

### 2.6 IIDC2 Digital Camera Control Specification Ver.1.1.0

This product is based on IIDC2 Digital Camera Control Specification Ver.1.1.0.

### 2.7 Random Trigger Shutter

The Random Trigger Shutter function provides images in any timing by input of an external trigger signal. Trigger control from PC is available as well.

## 2.8 Scalable

Selectable video output area. This mode achieves higher frame rate by reducing vertical output area. And reduces occupied data rate of Gigabit Ethernet by reducing horizontal output area.

## 2.9 Binning

Pixel data is combined by vertical and horizontal.

## 2.10 Decimation

Camera reads all effective areas at high speed by skipping lines.

## 2.11 ShortExposureMode

Firmware Ver.3.5.0 or later models have ShortExposureMode. By setting the ShortExposureMode to enable, high-speed exposure time setting from 1.08 $\mu$ s to 13.31 $\mu$ s is possible.

## 2.12 Optical Glass

Color models have built in optical glass.

Suffix of [G] attached to the model name indicates built-in optical glass model. (e.g. BG040MCG)

## 2.13 IR-cut filter

Build-in IR-cut filter models are optional for color models.

Suffix [F] is attached to the model name of built-in IR-cut filter model. (e.g. BG040MCF)

\* Suffix [F] is not shown in the common part of specifications.

## 2.14 Compact and lightweight

This camera is compact and lightweight; it is easy to integrate into industrial equipment.



### 3 Configuration

- Camera body 1

\* No application software and manuals are attached to this camera.

### 4 Optional part

- Camera mounting kit Model name: CPTBUBG

- Camera Cable CPCBG-xx

\* Contact your dealer / distributor for details of option units.

## 5 Functions

### 5.1 Gain

Manual gain and automatic gain control (AGC) settings are provided.

#### 5.1.1 Manual

The camera gain can be set manually.

Gain is adjustable from 0 to +24dB for firmware Ver.3.3.9 or earlier, 0 to +36dB for Ver.3.5.0 or later.

#### 5.1.2 AGC

The camera gain is automatically adjusted to suit subject brightness.

Range of gain setting at AGC mode is 0 to +24dB.

#### **Notes on gain setting:**

Setting the gain value too high increases noises. When you adjust the brightness of the image, we ask you to have final image quality checked with your environment.

### 5.2 Black Level

Black level is adjustable from -25% to +25% as white saturation level is 100%.

### 5.3 Gamma

Gamma correction curve is adjustable from 0.45 to 1.00.

### 5.4 LUT (Look Up Table)

Arbitrary curve and binarization are possible by using 12 bit input and 12 bit output LUT.

### 5.5 Packet Resend

GigEVision Packet Resend feature is supported.

### 5.6 Exposure Time

Manual exposure time and automatic exposure time control (AE) are available

#### 5.6.1 Manual

Exposure time is adjustable by micro-second unit. Firmware Ver.3.5.0 or later models have ShortExposureMode.

By setting the ShortExposureMode to enable (ON), high-speed exposure time setting from 1.08 $\mu$ s to 13.31 $\mu$ s is possible.

#### 5.6.2 AE

The exposure time is adjusted automatically to suit subject brightness.

This mode can also operate with AGC (Automatic Gain Control) to automatically adjust fluctuations in subject brightness across a wide range (ALC operation).

This feature is not supported when the ShortExposureMode is enable (ON).

**Notes on ShortExposureMode setting:**

- If you use ShortExposureMode, the image quality may deteriorate. Also, the actual exposure time may vary depending on the individual differences and the operating environment (such as the operating temperature). When using the ShortExposureMode, we ask you to have final image quality checked with your environment.
- The brightness of the upper part of the screen may be different from that of the lower part. Note that this is a characteristic of a CMOS image sensor and is not a fault.

## 5.7 White balance

Color models have two white balance modes, manual white balance (MWB) and one-push auto white balance (OPWB). Select the mode to suit the subject and purpose.

### 5.7.1 MWB

R/B gain can be set independently.

### 5.7.2 OPWB

When OPWB is executed, the camera adjusts R/B gain automatically.

## 5.8 Sharpness

It is possible to adjust the edge enhancement of the image for B/W models.

## 5.9 Chunk

It is possible to integrate some sort of information about each image with video data.

## 5.10 Random Trigger Shutter

An image is captured at the desired timing using trigger signal input. External trigger signal from trigger input connector and software trigger from control command are available (Edge mode / Bulk mode). Trigger polarity is selectable (High active / Low active).

Note that Random Trigger Shutter will cause a delay between trigger signal and start of exposure.

See 7. Timing Chart for detail.

### - Edge mode (TriggerSequence0)

The exposure time is determined by Exposure Time setting.

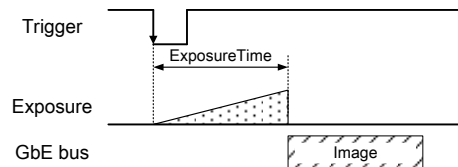

### - Level mode (TriggerSequence1)

The exposure time is determined by the pulse width of the trigger signal.

This feature is not supported when the ShortExposureMode is enable (ON).

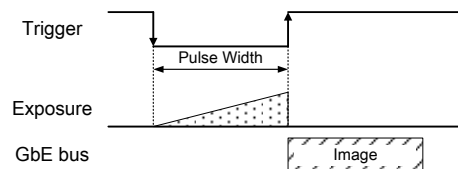

### - Bulk mode (TriggerSequence6)

Camera exposes and transfers multiple frames by a single trigger.

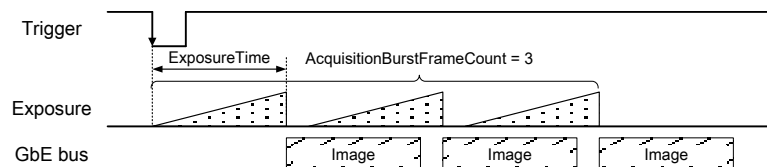

#### **Notes on Random Trigger Shutter mode:**

- In the period when FRAME\_TRIGGER\_WAIT signal is inactive, user must not input external trigger signal to this camera.
- When the interval of the input trigger signal is extremely short, or when the trigger signal is noisy, there is a possibility of causing the malfunction. In this case, please input a proper trigger signal.

### 5.11 Sequential Shutter

Sequential Shutter function performs sequential capturing with applying the settings of UserSet that have been made entry in advance. This feature is not supported when the ShortExposureMode is enable (ON).

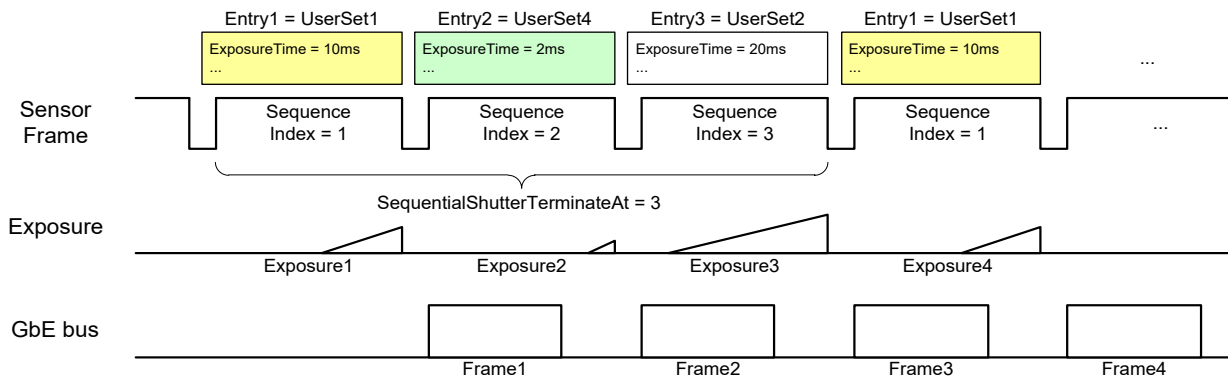

**Note on Sequential Shutter:**

- In Sequential Shutter mode, window size is unchangeable.

### 5.12 Trigger Delay

You can add the delay between trigger signal input and the start of exposure.

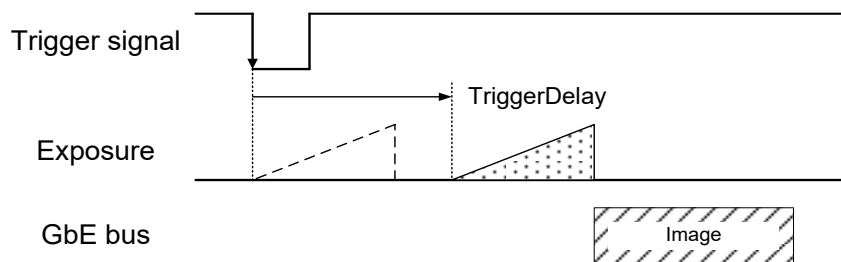

### 5.13 AntiGlitch-AntiChattering

AntiGlitch and AntiChattering functions filter noise and unstable state of the digital input (trigger signal).

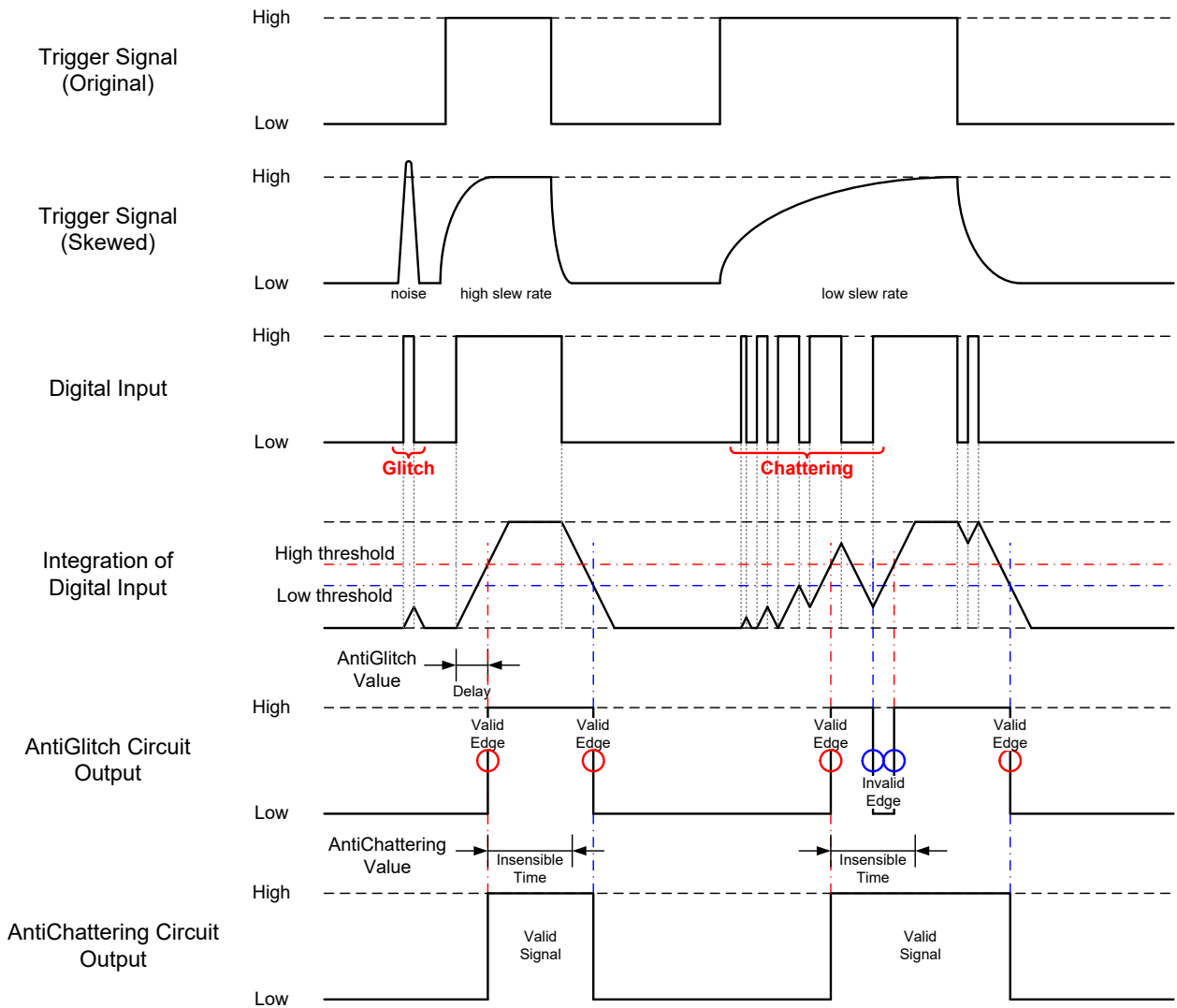

## 5.14 Event

Camera notifies of FrameTrigger status and other information by GigEVision Event Packet.

- FrameTrigger : Reception of Frame Start Trigger
- FrameTriggerError : Rejection of Frame Start Trigger
- FrameTriggerWait : Start of waiting for Frame Start Trigger
- FrameTransferStart : Start of transferring streaming data
- FrameTransferEnd : End of transferring streaming data
- ExposureStart : Start of Exposure
- ExposureEnd : End of Exposure
- Timer0Start : Start of Timer0
- Timer0End : End of Timer0

Events timing are as following chart.

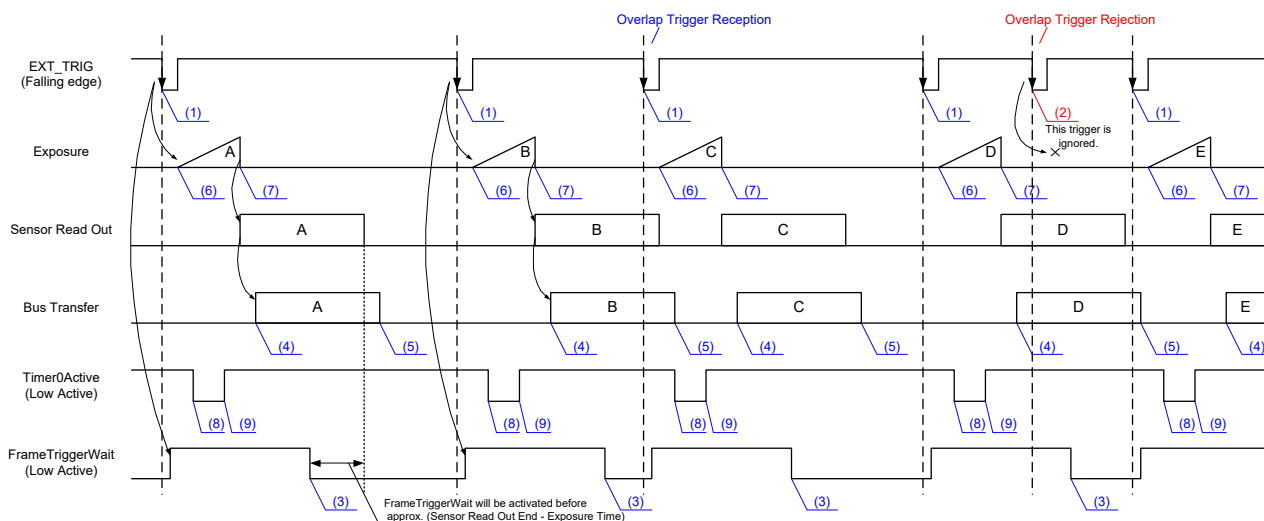

### Event Name

- (1) FrameTrigger : Reception of Frame Start Trigger.
- (2) FrameTriggerError : Rejection of Frame Start Trigger.
- (3) FrameTriggerWait : Start of waiting for Frame Start Trigger.
- (4) FrameTransferStart : Start of transferring streaming data.
- (5) FrameTransferEnd : End of transferring streaming data.
- (6) ExposureStart : Start of Exposure.
- (7) ExposureEnd : End of Exposure.
- (8) Timer0Start : Start of Timer0.
- (9) Timer0End : End of Timer0.

## 5.15 GPIO

Selected signals are output from GPIO pins of I/O connector. Following signals are selectable.

- TIMER0 ACTIVE : This signal can be used as strobe control signal.  
The delay time and pulse width of this signal are configurable.
- USER OUTPUT : Level selectable user output by register setting.
- EXPOSURE ACTIVE : Period from exposure start to end.  
(See 7. Timing Chart for detail.)
- FRAME ACTIVE : Period from exposure start to the CMOS transfer completion.
- FRAME TRANSFER : Period of transferring image data on USB bus.
- FRAME TRIGGER WAIT : Indicating waiting a Random Trigger Shutter.  
An External trigger is input during this period,  
exposure starts immediately.

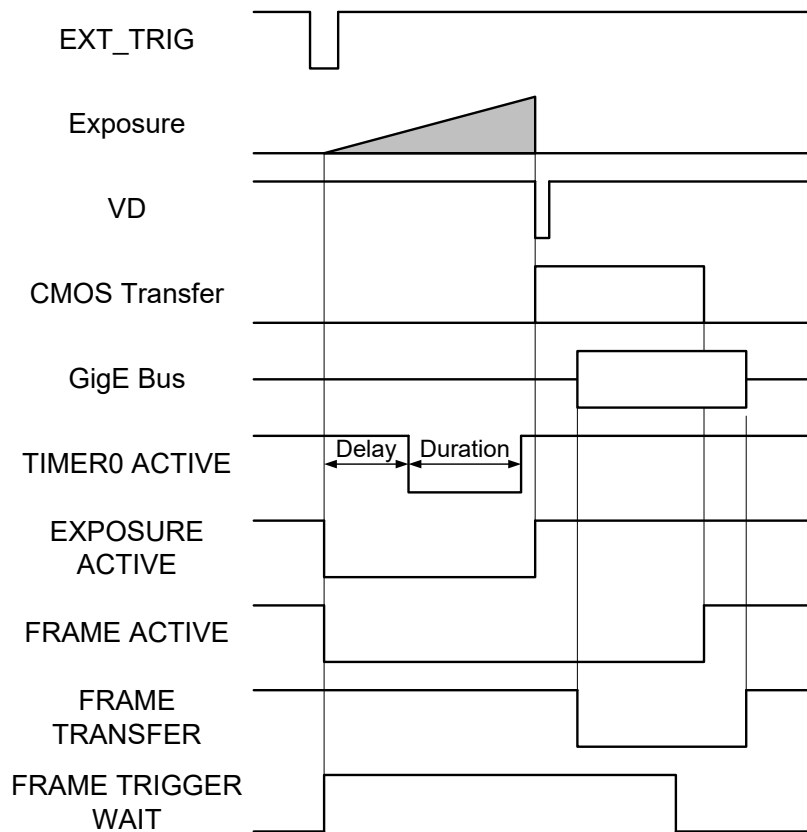

\* GPIO:default=Active Low



### 5.16 Scalable mode

Scalable mode is to read out arbitrary area of the image. Only single rectangle is selectable. Concave or convex shape is not selectable.

- Window size:  $\{A + 4 * m (H)\} * \{B + 2 * n (V)\}$

A, B = minimum unit size

m, n = integer

The window size is equal or less than maximum image size.

- Start address:  $\{4 * i (H)\} * \{2 * j (V)\}$

i, j = integer

The window size is equal or less than maximum image size.

	BG040M/BG040MCG	BG160M/BG160MCG
Width and OffsetX unit size	4	4
Height and OffsetY unit size	2	2
Minimum unit size (H) * (V)	64 x 64	64 x 64
Maximum unit size (H) * (V)	720 x 540	1440 x 1080

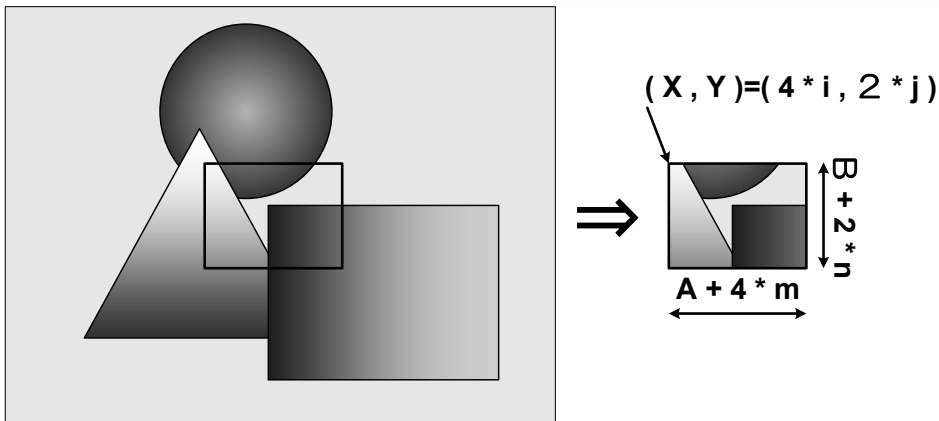

In the scalable mode, camera reads out only necessary area at the normal speed and reads out other area at high speed. The trigger interval can be shorter when the vertical height size is small.

### 5.17 Binning

In the binning mode, a pixel is added with the neighboring pixel(s).

\*Binning and Decimation cannot operate at the same time.

Binning		FrameRate			
Horizontal	Vertical	BG040M	BG040MCG	BG160M	BG160MCG
1	1	approx. 291 fps	approx. 291 fps	approx. 72 fps	approx. 72 fps
1	2	approx. 437 fps	approx. 437 fps	approx. 145 fps	approx. 145 fps
1	4	Incompatible	Incompatible	approx. 291 fps	approx. 226 fps
2	1	approx. 437 fps	approx. 437 fps	approx. 145 fps	approx. 226 fps
2	2			approx. 291 fps	
2	4	Incompatible	Incompatible	approx. 501 fps	
4	1			approx. 226 fps	
4	2			approx. 501 fps	
4	4				

### 5.18 Decimation

Decimation feature reads out all effective areas at high speed by skipping pixels and lines.

\*Binning and Decimation cannot operate at the same time.

Decimation		FrameRate			
Horizontal	Vertical	BG040M	BG040MCG	BG160M	BG160MCG
1	1	approx. 291 fps	approx. 291 fps	approx. 72 fps	approx. 72 fps
1	2	approx. 437 fps	approx. 437 fps	approx. 145 fps	approx. 145 fps
1	4	Incompatible	Incompatible	approx. 226 fps	approx. 226 fps
2	1	approx. 437 fps	approx. 437 fps	approx. 145 fps	approx. 145 fps
2	2			approx. 291 fps	approx. 291 fps
2	4	Incompatible	Incompatible	approx. 501 fps	approx. 501 fps
4	1			approx. 226 fps	approx. 226 fps
4	2			approx. 501 fps	
4	4				approx. 501 fps

### 5.19 Reverse

Image can be flipped in horizontal and/or vertical direction.

### 5.20 Defect Pixel Correction

Defect Pixel Correction is available up to 256 pixels.

### 5.21 Image Buffer

Camera stores images temporarily in image buffer, and read them out in arbitrary timing.

### 5.22 User Free Memory

A free memory area is available to read and write arbitrary data for user. Individual numbers can be assigned when multiple BG cameras are connected.

### 5.23 Test Pattern

Following test patterns are available

- Black : All pixels 0 LSB (@ 8-bit)
- White : All pixels 255 LSB (@ 8-bit)
- Grey A : All pixels 170 LSB (10101010<sub>B</sub>) (@ 8-bit)
- Grey B : All pixels 85 LSB (01010101<sub>B</sub>) (@ 8-bit)
- Horizontal ramp waveform
- Vertical ramp waveform
- Grey scale (B/W models only)
- Color Bar (Color models only)

## 6 Specifications

### 6.1 Electrical specification

Model Name	BG040M	BG160M
Imager	CMOS image sensor	
Maximum number of Video out pixels (H) x (V)	720×540	1440×1080
Scanning area (H) x (V) [mm]	5.02×3.82 (1/2.9 type)	5.00×3.75 (1/2.9 type)
Pixel size (H) x (V) [ $\mu\text{m}$ ]	6.90×6.90	3.45×3.45
Scan method	Progressive	
Electronic shutter method	Global shutter	
Aspect ratio	4:3	
Sensitivity	1890lx, F5.6, 1/333s	1700lx, F5.6, 1/77s
Minimum illuminance	Ver.3.3.9 or earlier : F1.4, Gain +24dB, Video level 50%	
	Ver.3.5.0 or later : F1.4, Gain +36dB, Video level 50%	
Gain	Ver.3.3.9 or earlier :4lx	Ver.3.3.9 or earlier :4lx
	Ver.3.5.0 or later : 1lx	Ver.3.5.0 or later : 1lx
Gain	MANUAL, AGC (factory setting : MANUAL)	
MANUAL	Ver.3.3.9 or earlier : 0 to +24dB (factory setting : 0dB) Ver.3.5.0 or later : 0 to +36dB (factory setting : 0dB)	
AGC effective range	0 to +24dB	
AGC area	Set in arbitrary percentage. (factory setting : 100% (full screen))	
Black Level	-25 to 25% (factory setting : 0% [ 0LSB@8bit ])	
Gamma	$\gamma=1.0$ to 0.45 (factory setting : $\gamma=1.0$ )	
LUT	Input 12 bit, Output 12 bit	
Sharpness	0(OFF) to 7 (factory setting : OFF)	
Image Buffer	64M Byte	
User Setting Memory	15 channels	
User Free Memory	64 Byte	
Test Pattern	Black, White, Grey A, Grey B Horizontal ramp waveform, Vertical ramp waveform, Grey scale (factory setting : OFF)	
Power supply	PoE (Power over Ethernet IEEE802.3af compliant) or DC+12V $\pm 10\%$ (ripple 100 mV(p-p) or less)	
Power consumption(*1)	PoE	3.3W(max)
	DC12V	2.7W(max)

(\*1) at all pixels readout

Model Name			
With optical glass		BG040MCG	BG160MCG
With IR-cut filter		BG040MCF	BG160MCF
Imager		CMOS image sensor	
Maximum number of Video out pixels (H) x (V)		720×540	1440×1080
Scanning area (H) x (V) [mm]		5.02×3.82 (1/2.9 type)	5.00×3.75 (1/2.9 type)
Pixel size (H) x (V) [μm]		6.90×6.90	3.45×3.45
Scan method		Progressive	
Electronic shutter method		Global shutter	
Aspect ratio		4:3	
Sensitivity			
With optical glass		1550lx, F4, 1/333s	2800lx, F5.6, 1/77s
With IR-cut filter		1650lx, F4, 1/333s	2800lx, F5.6, 1/77s
Minimum illuminance		F1.4, Gain +36dB, Video level 50%	
With optical glass		2lx	2lx
With IR-cut filter		2lx	2lx
Gain		MANUAL, AGC (factory setting : MANUAL)	
Setting range		0 to +36dB (factory setting : 0dB)	
AGC area		Set in arbitrary percentage. (factory setting : 100% (full screen))	
Black Level		-25 to 25% (factory setting : 0% [ 0LSB@8bit ])	
Gamma		γ=1.0 to 0.45 (factory setting : γ=1.0)	
White balance		MWB, OPWB (factory setting : MWB)	
Effective range		With optical glass : N/A	
		With IR-cut filter : 2,500 to 6,500K	
LUT		Input 12 bit, Output 12 bit	
Image Buffer		64M Byte	
User Setting Memory		15 channels	
User Free Memory		64 Byte	
Test Pattern		Black, White, Grey A, Grey B, Horizontal ramp waveform, Vertical ramp waveform, Color Bar (factory setting : OFF)	
Power supply		PoE (Power over Ethernet IEEE802.3af compliant) or DC+12V ±10% (ripple 100 mV(p-p) or less)	
Power consumption(*1)	PoE	3.4W(max)	
	DC12V	2.8W(max)	

(\*1) at all pixels readout

## 6.2 Electronic shutter specification

### Ver.3.3.9 or earlier

Model Name	BG040M	BG160M
Exposure time	MANUAL, AE (factory setting: MANUAL)	
MANUAL	30 $\mu$ s to 16s	
AE effective range	30 $\mu$ s to 1s	
AE effective area	Same as AGC effective area setting	
AE Exposure value	-2EV to +1.5EV	

### Ver.3.5.0 or later

Model Name	BG040M/BG040MCG	BG160M/BG160MCG
Exposure time	MANUAL, AE (factory setting: MANUAL)	
MANUAL		
ShortExposureMode=OFF	20 $\mu$ s to 16s	
ShortExposureMode=ON	1.08 $\mu$ s to 13.31 $\mu$ s	
AE effective range	20 $\mu$ s to 1s	
AE effective area	Same as AGC effective area setting	
AE Exposure value	-2EV to +1.5EV	

## 6.3 Random Trigger Shutter specification

Trigger Mode	External trigger, Software trigger (factory setting: External trigger)
External trigger	Input via I/O connector (Line0 or Line1)
Software trigger	GigE Vision Command control
Exposure time	Edge mode, Level mode, Bulk mode (factory setting: Edge mode)
Edge mode	The exposure time depends on the MANUAL Exposure time setting
Level mode	The exposure time depends on External trigger width
Bulk mode	The exposure time depends on the MANUAL Exposure time setting
Number of Exposures	Max 255 times
Trigger Delay	0 to 2000000 $\mu$ s (factory setting: 0 $\mu$ s)
AntiGlitch	90ns to 2ms (factory setting: 90ns)
AntiChattering	2 $\mu$ s to 2ms (factory setting: 2 $\mu$ s)

## 6.4 GPIO signal specification

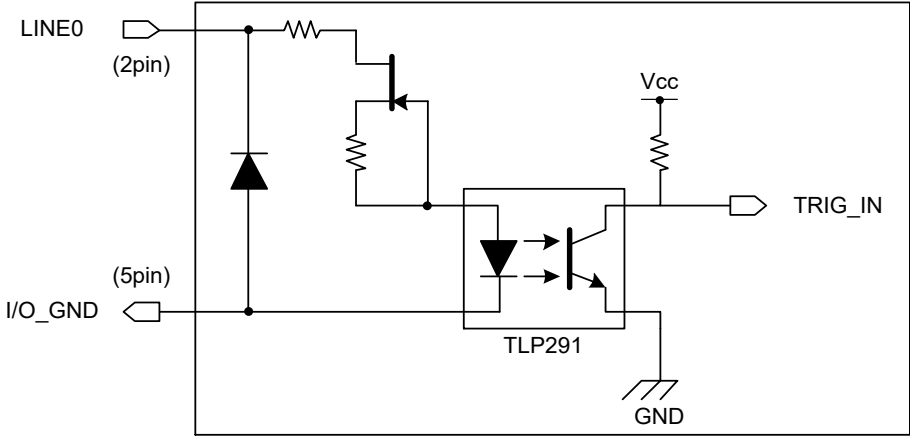
Line name	Line0
Direction	IN
Input signal	External trigger
Input level	Low: 0 to 0.5V, High: 3.3 to 24.0V
Input current	5 to 15mA
Pulse width	200μs (minimum)
Input circuit	Photo coupler input
	 <p>* Depending on cable length, cable kinds and input current of trigger input line, Random Trigger Shutter operation may not satisfy timing specification or camera may not receive External trigger signal.</p>
Polarity	High active / Low active (factory setting: Low active)

Line name	Line1	Line2
Direction	IN/OUT	OUT
Input signal	External trigger	-
Output signal	TIMER0 ACTIVE, USER OUTPUT, EXPOSURE ACTIVE, FRAME ACTIVE, FRAME TRANSFER, FRAME TRIGGER WAIT	
Maximum voltage	3.3V	24.0V
Maximum current	+/-24mA (drive current)	50mA (input current)
Input / Output circuit	LVTTL	Open Collector
Direction control	LineModeAll register (factory setting: IN)	-
Polarity	High active / Low active (factory setting: Low active)	
TIMER0 ACTIVE		
Delay	0 to 2000000μs (factory setting: 0s)	
Duration	0 to 2000000μs (factory setting: 0s)	
TimerTriggerSource	Line0Active, ExposureStart, FrameTrigger	

**Note on external trigger signal:**

- Depending on cable length, kind of cable and input current of trigger input line, external trigger signal may not be accepted by camera.
- Line0 and Line1 have a different input level. Please use input level within the voltage described in this specification.



## GPIO recommended circuit:

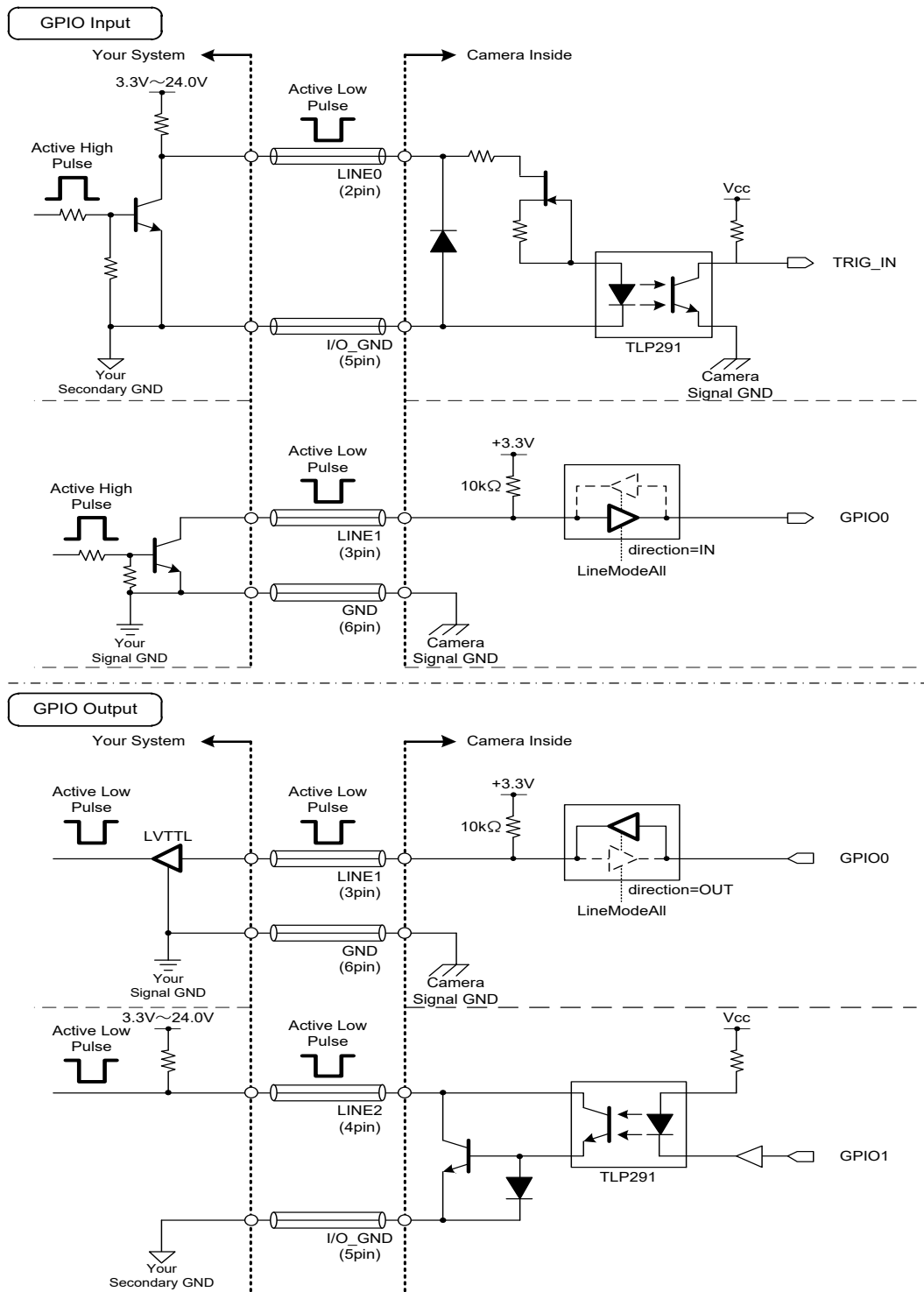

- Camera GND (Pin 6) and I/O\_GND (Pin 5) are mutually isolated.  
It is also possible to connect them to common GND of your system.
- Camera GND (Pin 6) and I/O\_GND (Pin 5) are isolated from camera frame.  
In using shield cable, the shield wire shall be connected to your frame ground or Camera GND (Pin 6).
- Please confirm the EMC adaptability in whole of your system.

## 6.5 Interface specification

Interface	Gigabit Ethernet IEEE802.3ab (1000BASE-T) conformity
Transmission speed	1Gbps (Maximum)
Protocol	GigEVision Camera Interface Standard for Machine Vision Ver 1.2
Conformity cable	Twist pair (Category 5e or over)
Cable length	Up to 100m (at the Unshielded Twist Pair (UTP) cable)

## 6.6 Image output format

Model		BG040M	BG160M
Image output format		GVSP_PIX_MONO8 (Mono 8bit)	
		GVSP_PIX_MONO10 (Mono 10bit)	
		GVSP_PIX_MONO12 (Mono 12bit)	
Maximum Frame rate (at all pixels readout)	Mono8	291 fps	72 fps
	Mono10, Mono12	145 fps	36 fps

\* 1000BASE-T Connecting

Model		BG040MCG	BG160MCG
Image output format		GVSP_PIX_BAYBG8 (BayerBG8 8 bit)	
		GVSP_PIX_BAYBG10 (BayerBG10 10 bit)	
		GVSP_PIX_BAYBG12 (BayerBG12 12 bit)	
Maximum Frame rate (at all pixels readout)	BayerBG8	291 fps	72 fps
	BayerBG10, BayerBG12	145 fps	36 fps

\* 1000BASE-T Connecting

### **Notes on Dropping Frames:**

Depends on your PC or Gigabit Ethernet interface board configurations, images may not be captured properly (e.g. dropping frames). In this case, change to frame rate setting lower.

## 6.7 Event notification

Event name	FrameTrigger, FrameTriggerError, FrameTriggerWait FrameTransferStart, FrameTransferEnd ExposureStart, ExposureEnd Timer0Start, Timer0End
Event notification delay	approx. 30us later from the event occurs
Time stamp unit	8ns (125MHz)

\* 1000BASE-T Connecting

## 6.8 Machine external specification

Dimensions	29 mm(W) x 29 mm (H) x 40 mm (D) (Not including protrusion)
Mass	Approximately 59g
Lens mount	C mount
Flange back	17.526mm
Camera body grounding insulation status	Non-conductive between circuit GND and camera body

## 6.9 Operation Ambient conditions

Operation assurance	Temperature: 0°C to +40 °C Camera housing temperature: less than 60 °C Humidity: 10% to 90% (no condensation)
Storage assurance	Temperature: -20°C to +60 °C Humidity: 90% or less (no condensation)
EMC condition	EMI (Electro-Magnetic interference) : EN61000-6-4 FCC Part 15 Subpart B Class A EMS (Electro-Magnetic susceptibility) : EN61000-6-2

### **Notes on Heat Radiation:**

About the upper limit of top surface temperature of camera housing and the allowed ambient temperature of each model, please refer to the "Thermal design manual" on our website.

Thermal Design Guide Line

<https://www.toshiba-teli.co.jp/en/products/industrial/info/t/t0001.htm>

### **Notes on Conformity of the EMC:**

The adaptability of the safety standard of this camera is assured in the condition of combination with the following parts:

<<PoE operation>>

- PoE Switch                      GS108PE                      (NETGEAR Inc.)
- LAN Cable                        LD-TWST/BM30                (ELECOM CO., LTD)

<<DC operation>>

- DC Cable                          CPCBG-03
- LAN Cable                        LD-TWST/BM30                (ELECOM CO., LTD)

Please confirm the EMC adaptability when it combines with parts other than them.

6.10 Connector pin assignment

<b>Gigabit Ethernet interface connector</b>			
RJ-45 Jack			
Pin No.	I/O	Signal Name	Function
1	I/O	BI_DA+ / VDC+	Bidirectional Data A (+) / Power (+)
2	I/O	BI_DA- / VDC+	Bidirectional Data A (-) / Power (+)
3	I/O	BI_DB+ / VDC-	Bidirectional Data B (+) / Power (-)
4	I/O	BI_DC+ / VDC+	Bidirectional Data C (+) / Power (+)
5	I/O	BI_DC- / VDC+	Bidirectional Data C (-) / Power (+)
6	I/O	BI_DB- / VDC-	Bidirectional Data B (-) / Power (-)
7	I/O	BI_DD+ / VDC-	Bidirectional Data D (+) / Power (-)
8	I/O	BI_DD- / VDC-	Bidirectional Data D (-) / Power (-)

**I/O Connector**

Connector (Camera side)                      HR10A-7R-6PB(73) (Hirose) or equivalent  
 Plug (Cable side)                              HR10A-7P-6S(73) (Hirose) or equivalent

Camera cable is not an accessory of this product.

Connector view from mating face

Camera side

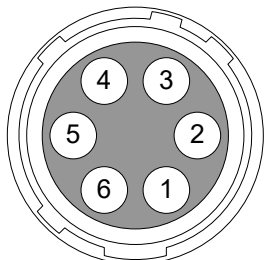

Cable side

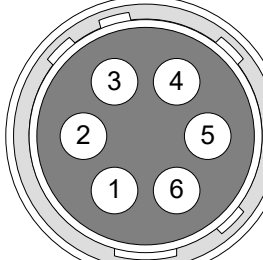

↑ TOP

Pin No.	I/O	Signal Name	Function
1	I	+12V	Power
2	I	Line 0	External Trigger Input
3	I/O	Line 1	GPIO_0 Output / External Trigger Input
4	O	Line 2	GPIO_1 Output
5	-	I/O GND	GPIO_Ground
6	-	GND	Ground

**Notes on Power Supply:**

This camera has two ways of power supply,

- Supply from LAN cable (PoE)
- Supply from camera cable (DC+12V ±10%)

If both PoE and DC+12V are connected, power is supplied from PoE.

### 6.11 Typical spectral response

The lens characteristics and light source characteristics is not reflected in table.

< BG040M / BG160M >

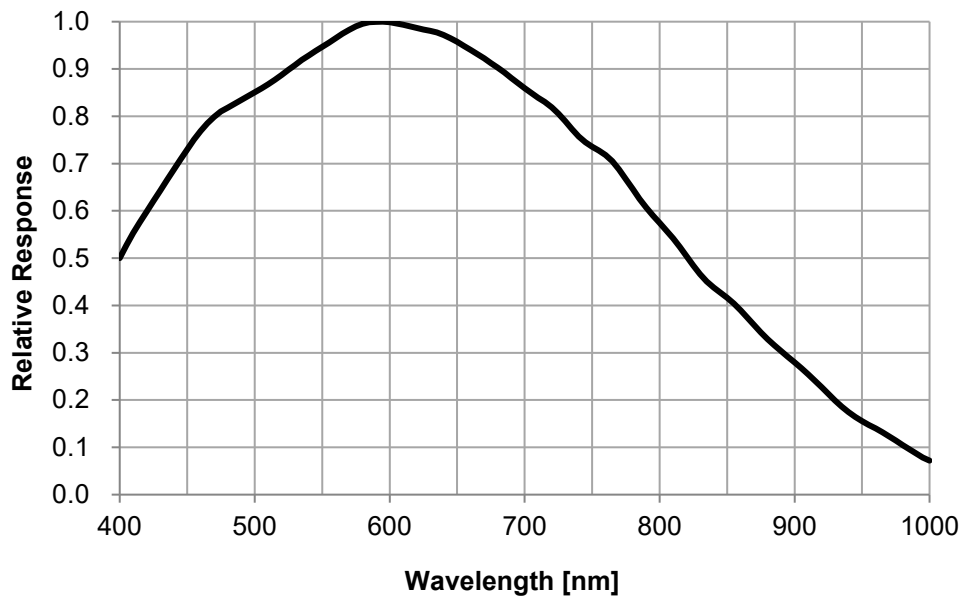

< BG040MCG >

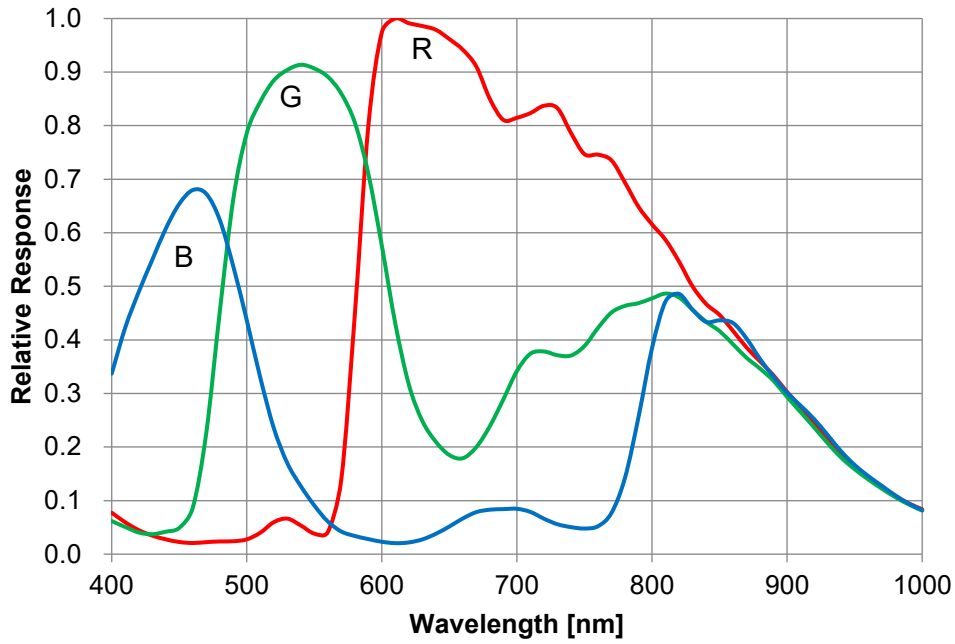

< BG160MCG >

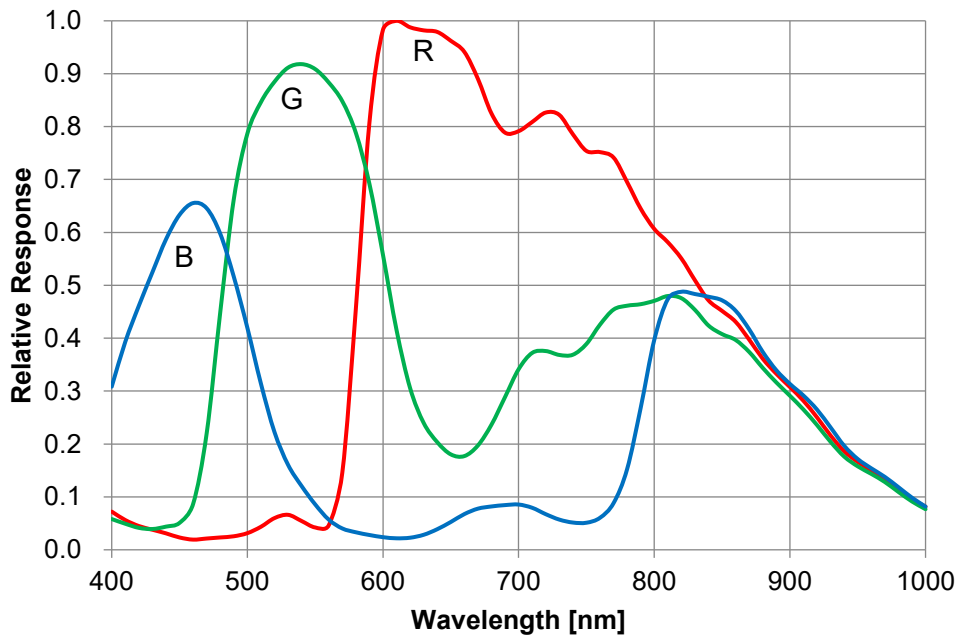

< BG040MCF >

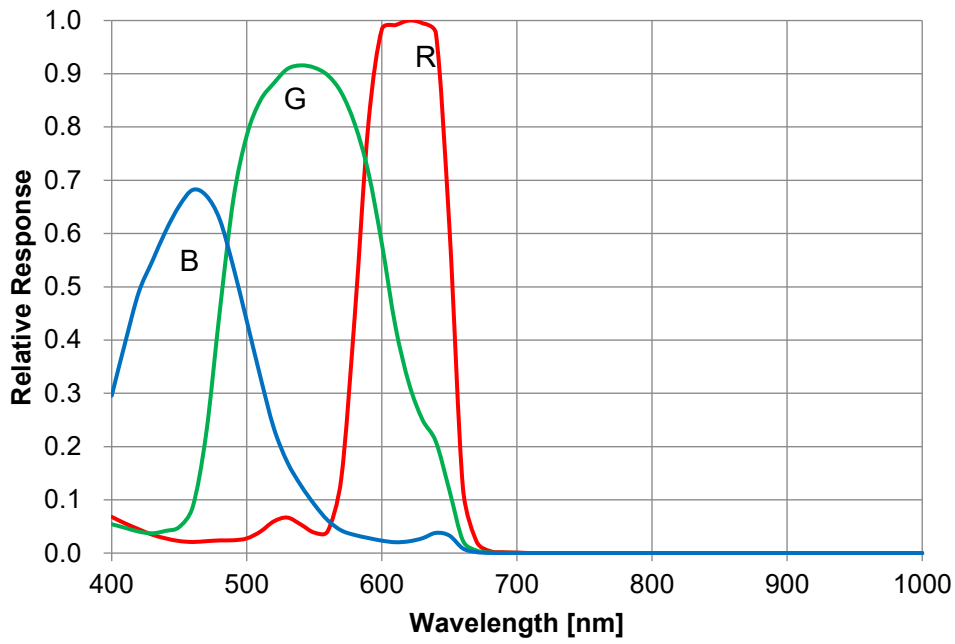

< BG160MCF >

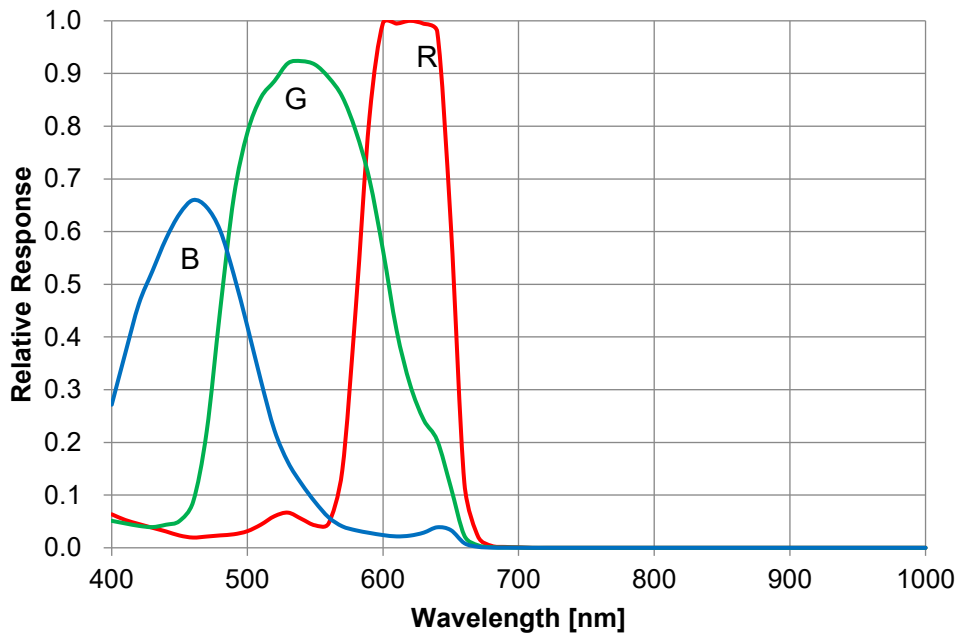

## 7 Timing chart

Image data outputs are transferred with the UDP protocol of Gigabit Ethernet. Timing numerical value below is described by absolute prerequisite that camera can use transmission band without restriction of other node. When there is other node using the same network, the value described below is not guaranteed.

### 7.1 GbE bus transfer timing (at all pixels readout)

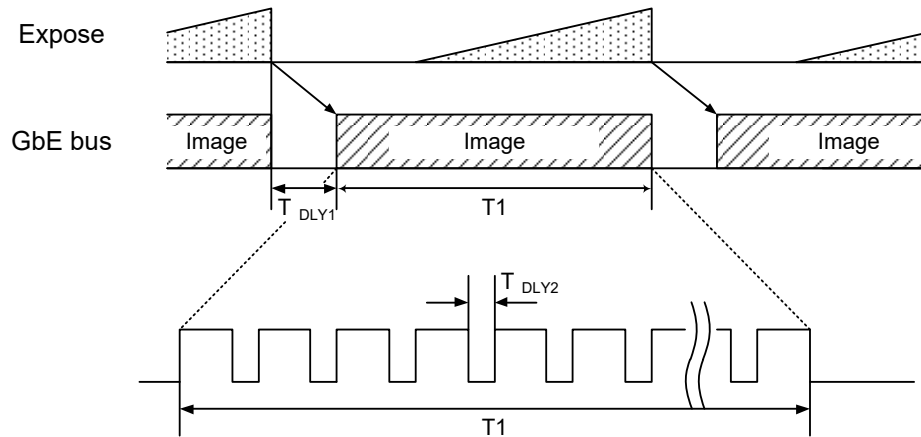

Model Name	T1 [ms]	Default Frame Rate [ms]
BG040M/BG040MCG	Maximum frame rate (in [ms]) of operating mode.	3.43
BG160M/BG160MCG		13.7

\*  $T_{DLY1}$  : BlockStartDelay

\*  $T_{DLY2}$  : SCPD (Stream Channel Packet Delay)

BlockStartDelay and SCPD are able to be controlled by application software.

\* Depending on Frame Rate and PacketSize setting,  $T_{DLY2}$  might be inserted automatically despite SCPD=0.

\* Timing chart is at the time of 1000BASE-T connection.



## 7.2 Random Trigger Shutter timing

### 7.2.1 External trigger signal input

External trigger signal input circuits of LINE0, LINE1 are different.

Internal signal delay is dependent on LINE.

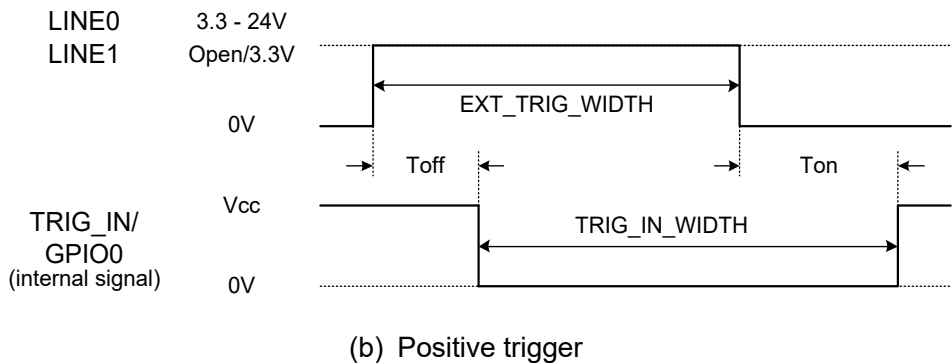
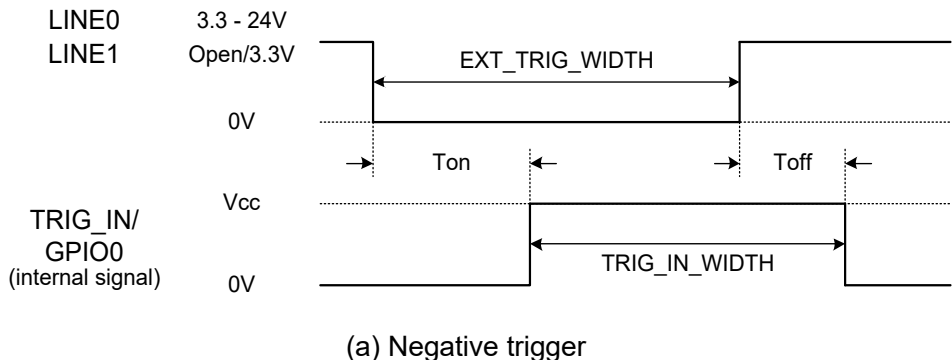

EXT\_TRIG\_WIDTH : The pulse width of the external trigger input.

Toff : The delay time of falling edge.

Ton : The delay time of rising edge.

TRIG\_IN\_WIDTH : The pulse width of the trigger signal which is received inside of the camera.

- Negative trigger :  $TRIG\_IN\_WIDTH = EXT\_TRIG\_WIDTH - (Ton - Toff)$

- Positive trigger :  $TRIG\_IN\_WIDTH = EXT\_TRIG\_WIDTH + (Ton - Toff)$

	Signal Amplitude	Toff [ $\mu$ s]	Ton [ $\mu$ s]
LINE0	+3.3V	2.6	22
	+12V	2.0	25
	+24V	1.9	26
LINE1	Open/+3.3V	<0.02	<0.02

\* Measured with 2.2k ohm pulled up register on LINE0.

\* Toff and Ton are typical value. These values vary depending on operating environment.

### 7.2.2 Edge mode / Bulk mode (at all pixels readout)

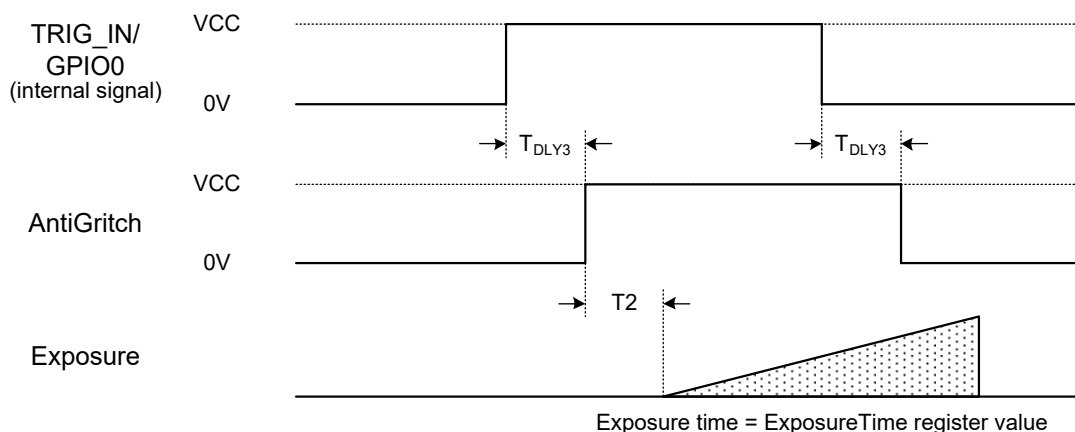

### 7.2.3 Level mode (at all pixels readout)

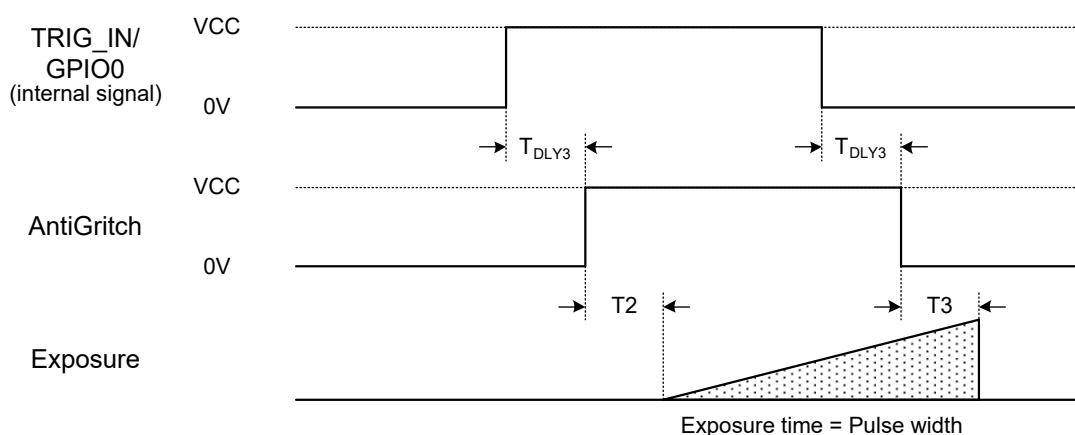

Model Name	T2 [ $\mu$ s]	T3 [ $\mu$ s]
BG040M/BG040MCG	12.1	26.3
BG160M/BG160MCG	12.1	26.4

\*  $T_{DLY3}$  : Delay time is the same as AntiGlitch setting value.  
AntiChattering does not effect delay time.

\* T2 and T3 are typical value.

#### **Notes on Random Trigger Shutter mode:**

- In the period when FRAME\_TRIGGER\_WAIT signal is inactive, user must not input external trigger signal to this camera.
- When the interval of the input trigger signal is extremely short, or when the trigger signal is noisy, there is a possibility of causing the malfunction. In this case, please input a proper trigger signal.

## 7.2.4 GPIO signal output

GPIO signal output circuits of LINE1, LINE2 are different.

Output signal delay is dependent on LINE.

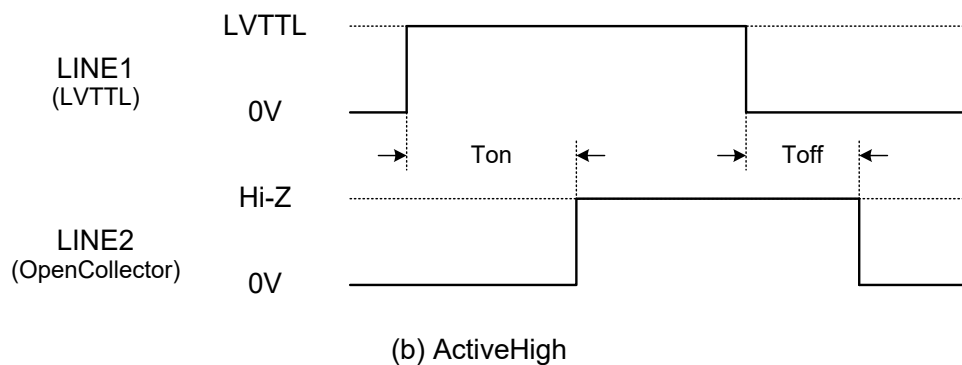
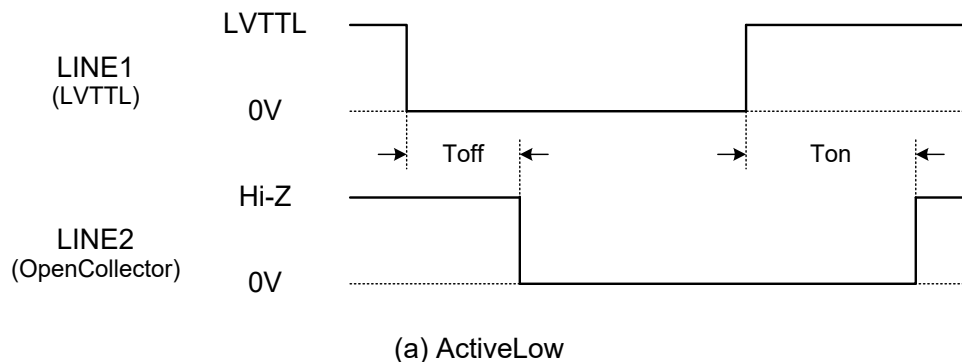

T<sub>off</sub> : LINE1~LINE2 falling delay time

T<sub>on</sub> : LINE1~LINE2 rising delay time

Signal amplitude	T <sub>off</sub> [μs]	T <sub>on</sub> [μs]
+3.3V	3	22
+12V	2	26
+24V	2	26

\* Measured with 2.2k ohm pulled up register on LINE2.

\* T<sub>off</sub> and T<sub>on</sub> are typical value. These values vary depending on operating environment.

## 8 Warranty rules

### 8.1 Warranty term

Warranty term is 36 months after your purchase. We may assume the date of the purchase from our shipping date when the date is unidentified.

### 8.2 Limited Warranty

Free warranty is not applicable for the troubles, damages or losses caused by the cases of the followings, even if it is during the warranty term.

1. Natural exhaust, wear or degradation of a component parts
2. Handling against the instructions and conditions described in the instruction manual
3. Remodeling, adjustment and the part exchange. (including the opening of the enclosure box and the alteration)
4. Using the accessories not included with the product or our non-designated optional articles
5. Damages caused during the transportation or deficiency of the handling such as drop or fall of the products after the products having been transferred to customers, leaving the products to corrosive environment such as sunlight, fire, sand, soil, heat, moisture, or an inappropriate storing method
6. A fire, an earthquake, a flood, a lightning, or other natural disasters, pollution and a short circuit, abnormal voltage, excessive physical pressure, theft, other accident
7. When connected to a product which is not recommended
8. When connected to the power supply which is not suitable
9. Forgery product, products which does not have proper serial number, products of which serial number is forged, damaged or deleted
10. All defects that happened after the expiration for a warranty term

## 9 Repair

### 9.1 Repair Methods

Exchange to a replacement or an equal function product.

### 9.2 Repair request methods

On the occasion of a repair request, please download the "Failure situation report sheet" from our website, fill in the necessary items and return it together with the defective product.

Repair Request Methods

[https://www.toshiba-teli.co.jp/en/support/contact/failure\\_situation.htm](https://www.toshiba-teli.co.jp/en/support/contact/failure_situation.htm)

Please read the following instructions carefully.

1. Please return our product alone, taking out of your equipment in case that our product is installed to an equipment
2. We are unable to return the information such as your own serial numbers, control number, the identification seal, if it is attached to the returned products. Please keep record before you return the product.
3. As the data saved in the camera will not be kept after the repair, please take out data before return.
4. We are unable to accept the cancellation after the repair request by the customer's reason.
5. About the repair product shipping expenses, please bear the charges when you return the product to us. We bear the charges to you from us only for a warranty period.
6. We are unable to accept your request of a delivery date and time of the product return, or the delivery method.
7. We are unable to accept a trouble factor investigation, the request of the repair report.
8. We accept a repair of out of warranty product, if it is repairable.
9. The proprietary rights of the repair request products after the exchange repair belong to us.
10. The immunity from responsibility of the product is applied in the repair completion products.

\* Please refer for the inquiry about the software to our website or sales personnel.

# 10 Outline Drawing

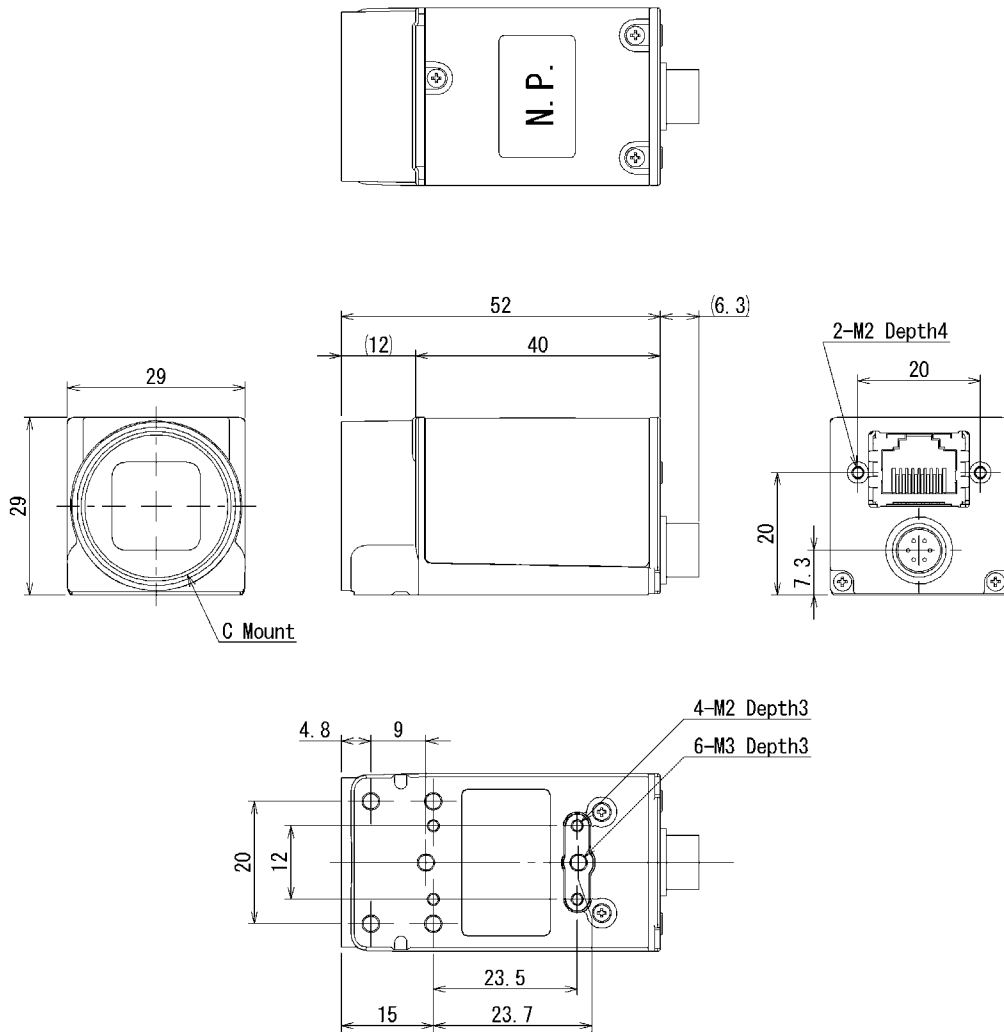

**Specification**

**Material**

Lens mount, Rear panel : Aluminun die cast  
 Cover : Anticorrosion aluminum alloy

**Processing**

Lens mount, Cover, Rear panel : Anion coating(black)

[Unit : mm]