



CCD Monochrome Video Camera Specifications

CS8630BH

Contents

1. Product description.....	1
2. Features	1
3. Configuration	2
4. Specification	2
5. Guarantee	7
6. Repair.....	7
7. Appearance	8

TOSHIBA TELI CORPORATION



Important Safety Precautions

BEFORE USE - GENERAL SAFETY INSTRUCTIONS

This specifications contains important information for the operator (user) and/or people in the vicinity to avoid personal injury, or property damage.

- Prior to use, read this specifications carefully to fully understand its instructions for correct use.
- After reading, keep operation manual near the equipment for future reference.



WARNINGS & CAUTIONS

Indication	Meaning
 WARNING	This mark indicates the user that improper use may cause death or serious injuries (*1) of user or people in the vicinity.
 CAUTION	This mark indicates the user that improper use may cause injuries(*2) or material damages(*3) against the user or people in the vicinity.

Notes

- *1 Serious injuries means wounds, loss of sight, burns, electric shocks, fractures, poisoning, and others for which hospitalization or long term care are required.
- *2 Injuries means wounds, burns, electric shocks, and others for which hospitalization or long term care are not required.
- *3 Material damage means any direct or consequential damage related to property or material loss.

Graphic symbol definitions

Indication	Meaning
	This mark indicates a prohibited action that must not be carried out. The actual prohibited action is indicated in the symbol or nearby graphically or described in text.
	This mark indicates a mandatory action that must not be carried out. The actual instruction is indicated in the symbol or nearby graphically or described in text.

● Handling Precautions

WARNING



Stop operation immediately when any abnormality or defect occurs.

Use during an abnormal condition; such as emitting smoke, burning odors, damage from dropping invasion of foreign objects, etc. may cause fire and/or electric shock. Be always sure to disconnect the power plug from the electrical outlet (socket) at once and contact your dealer.



Do not operate in places with possibility of becoming wet.

This may cause fire and/or electric shock.



Do not repair, disassemble and/or modify by yourself.

This may cause fire and/or electric shock. Be always sure to contact your dealer for internal repair, check and cleaning of the product.



Don't place things or materials on the unit.

Ingress of foreign materials such as metallic things and liquid into the unit may cause a fire or an electric shock.



Do not put the product in an unstable, slanting and/or vibrated place.

Drop and/or fall of the product may cause injury.



Do not touch the power cord or other connection cables during a thunderstorm.

This might cause electric shock.



Use the specified power supply.

Use of an unspecified power supply may result in fire or electric shock.



Do not be handled roughly, damaged, fabricated, bent forcefully, pulled, twisted, bundled, placed under heavy objects or heated the power cord, connection cable.

Otherwise, fire or electric shock may result.



CAUTION



Note the following instructions when installing.

-Do not wrap the product in an inflammable material, such as cloth.

-Do not put the product in a narrow space, since the heat generated from the product may be difficult to emanate.

If you do not follow the above, the heat generated by the product may cause fire.



Avoid setting in humid, smoky, vaporized or dusty places. A fire or an electric shock may occur in such places.

This may cause fire and/or electric shock.



Do not put the product in direct sunshine and/or high temperature.

The temperature inside the product may cause fire.



Use the specified DC power cable or connection cable.

Otherwise, a fire or an electric shock may occur.



Turn OFF the power in the case of connection.

Turn OFF the power in the case of connection of power cable or connection cable.

Otherwise, an electric shock or a malfunction may occur.



Do not expose its camera head to any intensive light (such as direct sunlight).

Otherwise, its inner image pickup device might get damaged.



Avoid short-circuiting signal output.

Otherwise, a malfunction may occur.



Avoid giving a strong shock against the camera body.

It might cause a breakdown or damage.

If your camera is used in a system where its camera connector is subjected to strong repetitive shocks, its camera connector is possible to break down. If you intend to use your camera in such a situation, if possible, bundle and fix a camera cable in the place near the camera, and do not transmit a shock to the camera connector.



Ask your dealer to perform a periodical check and internal cleaning (approx. once every five years).

Dust inside the product may cause fire and/or trouble. For check and cleaning cost, please consult your dealer.

DISCLAIMER (LIMITED WARRANTY)

We disclaim any responsibility and shall be held harmless for any damages or losses incurred by the user in any of the following cases;

- Fire, earthquake or any other act of God; acts by third parties; misuse by the user, whether intentional or accidental; use under extreme operating conditions.
- Malfunction or non-function resulting in indirect, additional or consequential damages, including but not limited to loss of expected income and suspension of business activities.
- Incorrect use not in compliance with instructions in this instruction specifications and manual.
- Malfunctions resulting from misconnection to other equipment.
- Repairs or modifications made by the user or caused to be made by the user and carried out by an unauthorized third party.
- Notwithstanding the foregoing, Teli's liabilities shall not, in any circumstances, exceed the purchase price of the product.
- About the item which does not have a publication in the specifications and manual of this product, it considers as the outside for a guarantee.

RESTRICTION FOR USE

- Should the equipment be used in the following conditions or environments, give consideration to safely measures and inform us of such usage:
 1. Use of the equipment in the conditions or environment contrary to those specified, or use outdoors.
 2. Use of the equipment in applications expected to cause potential hazard to people or property, which require special safety measures to be adopted.
- This product can be used under diverse operating conditions. Determination of applicability of equipment or devices concerned shall be determined after analysis or testing as necessary by the designer of such equipment or devices, or personnel related to the specifications. Such designer or personnel shall assure the performance and safety of the equipment or devices.
- This product is not designed or manufactured to be used for control of equipment directly concerned with human life (*1) or equipment relating to maintenance of public services/functions involving factors of safety (*2). Therefore, the product shall not be used for such applications.
 - (*1): Equipment directly concerned with human life refers to.
 - Medical equipment such as life-support systems, equipment for operating rooms.
 - Exhaust control equipment for exhaust gases such as toxic fumes or smoke.
 - Equipment mandatory to be installed by various laws and regulations such as the Fire Act or Building Standard Law
 - Equipment related to the above.
 - (*2) : Equipment relating to maintenance of public services/functions involving factors of safety refers to.
 - Traffic control systems for air transportations, railways, roads, or marine transportation
 - Equipment for nuclear power generation
 - Equipment related to the above

CAUTIONS ON USE

- Carefully handle the units.

Do not drop, or give a strong shock or vibration to the camera. This may cause problems. Treat the camera cables carefully to prevent cable problems, such as cable breakdown and loosened connections.

- Operating ambient temperature and humidity.

Do not use the camera in places where temperature and humidity exceed the specifications. Picture quality will lower and internal parts may be damaged.

Be particularly careful when using in places exposed to direct sunlight. When shooting in hot places, depending on the conditions of the object and the camera (for example when the gain is increased), noise in the form of vertical strips or white dots may occur. This is not a malfunction.

- Combination of C-mount lens

Depending on the lens you use, the performance of the camera may not be brought out fully due to the deterioration in resolution and brightness in the peripheral area, occurrence of a ghost, aberration and others.

When you check the combination between the lens and camera, be sure to use the lens you actually use.

As for the C-mount lens used combining this product, the projection distance from bottom of the screw should use 7.7mm or less.

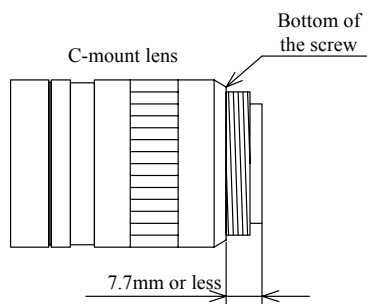

- Restriction for the lens combination

This camera might form a ghost to image area depending on the combination of a lens and an illumination with this camera. But this is not a failure of this camera. Therefore, please check the combination of the lens and the illumination with this camera when use.

When mounting a lens, take extra caution so that the lens is not tilted, nor does flaw exist at the lens-mount-screw part. Also check to confirm that no dirt nor other foreign object is put inside. Improper mounting might cause the parts to become locked.

- Do not shoot under intense light.

Avoid intense light such as spot light on part of the screen because it may cause blooming or smears. If intense light falls on the screen, vertical stripes may appear on the screen, but this is not a malfunction.

- Do not expose the camera's image-pickup-plane to sunlight or other intense light directly.

Its inner CCD (charge-coupled device) might be damaged.

- Moire

When thin stripe patterns are shot, stripe patterns that are not actually there (moire) may appear as interference stripes. This is not a malfunction.

- Undesirable noise

If the camera or the cables are located near something which emit strong magnetism or near something which emit strong electric wave, undesirable noise may appear on the screen. In such a case, try to change the location of the camera or the cable wiring.

- Handling of the protection cap

When the camera is not in use, put a lens-cap onto the camera head for protection of the image-pickup-plane.

- When not using the camera for a longtime.

Stop supplying power for safety.

CAUTIONS ON USE

- When cleaning the camera
Always turn off the power and clean with a piece of soft dry cloth.
To remove stubborn stains, use a soft cloth soaked in diluted acid-free detergent. Do not use alcohol, benzine, thinner, etc. If used, coating and printed letters may be discolored.
In case the image-pickup-plane should be settled with fine dust, dirt, or scratched, ask your dealer for technical advice.
- Wastes of this product should be separated and discarded in compliance with the various national and local ordinances.
- When cleaning the camera
Always turn off the power and clean with a piece of soft dry cloth.
To remove stubborn stains, use a soft cloth soaked in diluted acid-free detergent. Do not use alcohol, benzine, thinner, etc. If used, coating and printed letters may be discolored.
In case the image-pickup-plane should be settled with fine dust, dirt, or scratched, ask your dealer for technical advice.
- Wastes of this product should be separated and discarded in compliance with the various national and local ordinances.

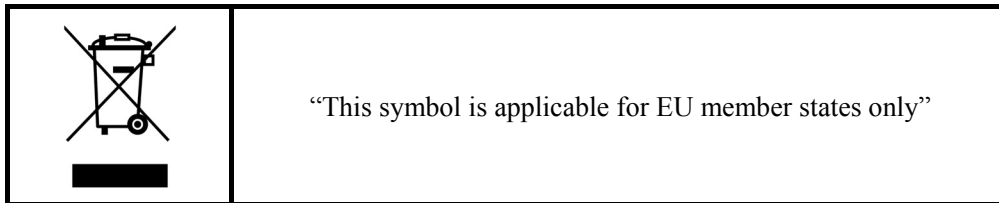

1. PRODUCT DESCRIPTION

Model CS8630BH is a miniature camera series featuring its ultra-small light-weight body. The CS8630BH is designed mainly for factory automation, machine vision, and image measurement application.

2 FEATURES

(1) High resolution

The 380,000 pixel CCD realizes the horizontal resolution of 570TV lines.

High-density images with minimum moire-fringes & beatings are obtained

(2) Ultra-compact & light-weight body

The camera features its ultra-small light-weight body. Its super-small body will free you from much of your space restriction problem. The camera is driven by DC12V.

(3) Electronic shutter

The built-in electronic shutter allows this camera to capture a fast-moving object clearly and sharply.

(4) AGC (Automatic Gain Control)

This series is equipped with AGC function. With the AGC, the camera obtains optimal images constantly even when the amount of incoming light fluctuates.

(5) Restart/Reset

When the restart/reset function set ON, the camera captures images at any timing given by R.R. pulse input (VD input).

Remark : CS8620BHi, CS8620BHCi are possible for a restart/reset operation only at the field integration mode.

(6) SS (Special shutter) & RTS (Random trigger shutter)

This camera is fitted with special shutter and random trigger shutter function, which allows the camera to capture images cued by external trigger input.

(7) Near-infrared region sensitivity (Model -----H type only)

The CCD has a near-infrared-region sensitivity. This model captures clear images even under near-IR shooting condition.

3. CONFIGURATION

- (1) Camera body 1
- (2) Accessory
 - Manual 1

4. SPECIFICATION

- (1) TV system Based on EIA standard
- (2) Image sensor Interline CCD
 - Total pixel counts 811(H)×508(V)
 - Active pixel counts 768(H)×494(V)
 - Video output pixel counts 756(H)×485(V)
 - Cell size 6.35×7.4 μm
 - Scanning area 4.8×3.6mm (type-1/3)
 - H drive frequency (Internal sync) 14.31818MHz ±100ppm
- (3) Scanning lines 525 lines
- (4) Scanning format 2 : 1 interlace
- (5) Sync System Internal/External (automatic change over)
- (6) Scanning frequencies (internal synchronization mode)
 - Horizontal drive (H) 15.734kHz ±100ppm
 - Vertical drive (V) 59.94Hz ±100ppm
- (7) Aspect ratio 4:3
- (8) Sensitivity
 - Standard (GAIN:MGC, $\gamma = 1.0$) 400 lx , F8 (3100K)
 - Minimum (GAIN:MAX, $\gamma = 0.45$) 0.2 lx , F1.4
- (9) Video output VS:1.0V(p-p) /75 Ω
 - VS (Video + SYNC)
- (10) Resolution
 - Horizontal 570 TV lines
 - Vertical 485 lines (350 TV lines)
- (11) S/N 60dB(p-p)/rms (typical)
(GAIN:MGC, $\gamma = 1.0$)
- (12) Input signal
 - ① External sync pulses HD•VD/SYNC/VS
 - Pulse level HD, VD, SYNC:2~6V(p-p)
VS:1.0(SYNC0.3)V(p-p)
 - Input impedance 75 Ω / High Switch-able by the panel SW
(Initial factory setting: High)
 - Scanning system 2 : 1 interlace

- Polarity Negative
- Pulse width HD: $6.4 \pm 3 \mu s$
VD: $150 \sim 800 \mu s$
- Frequency
Horizontal (fH) $fH = 15.734 \text{ kHz} \pm 2\%$
Vertical (fV) $fV = 2fH / 525$
- Scanning lines 525 lines
- Phase different The difference in phase between the falling edge of VD and that of HD is shown in the figure below.

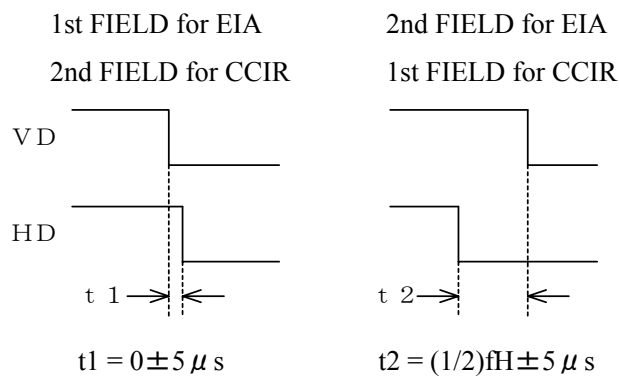

② Shutter trigger (TRG)

- Pulse level VL=0~0.5V VH=2~5V
- Input impedance High impedance
- Polarity Positive
- Pulse width $2 \mu s \sim 1/4s$

(13) Output signal

① HD/VD pulses

- Under internal sync operation, output available by the panel SW selection (Initial factory setting: IN)
- Output level (high impedance) HD: $4.5 \pm 0.5V(p-p)$
VD: $5.0 \pm 0.5V(p-p)$
- Scanning system 2 : 1 interlace
- Polarity Negative
- Pulse width HD: $6.36 \pm 1 \mu s$, VD: $572 \pm 10 \mu s$

- Frequency
 - Horizontal (fH) $fH=15.734\text{kHz} \pm 100\text{ppm}$
 - Vertical (fV) $fV=2fH/525$
- Scanning lines 525 lines

② Clock pulse

- Output level $2.0 \pm 0.3\text{V(p-p)}$ (high impedance)
- Frequency (Under internal synchronization) $14.31818 \text{ MHz} \pm 100\text{ppm}$

③ WEN

Under random trigger shutter operation, WEN is output during the period starting from the VIDEO OUT START VD falling edge through the VIDEO OUT END VD falling edge.

- Polarity Positive
- Diagram The circuit is shown in the figure below.

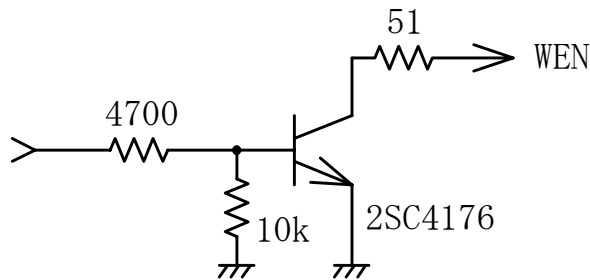

- (14) Sensitivity setting Mode selection via panel SW (Initial factory setting: MGC)
AGC(Automatic Gain Control)
MGC (Manual Gain Control)
- (15) MGC Manual sensitivity adjustment available
- (16) Gamma 1.0 / 0.45 selectable via rear panel DIP switch
(Initial factory setting: 1.0)
- (17) White clip Clip-level: $820 \pm 40\text{mV(p-p)}$ (Excluding SYNC)
- (18) Electronic shutter Normal shutter
The following shutter speed setup is possible by rear panel DIP switch selection.
Normal, 1/125, 1/250, 1/500, 1/1000, 1/2000, 1/4000, 1/10000s, and Flicker-less (Initial Factory setting: Normal)
Slow-speed shutter
1FLD, 2FLD, 4FLD, 6FLD, 8FLD, and 10FLD

(19) Random trigger shutter

RTS Mode selection available

1	Shutter-speed Switch Setting	Internal sync	SYNC Non-reset
2	Shutter-speed TRIG Pulse-width Setting	Internal sync	SYNC Non-reset
3	Shutter-speed Switch Setting	Internal sync	SYNC Reset
4	Shutter-speed TRIG Pulse-width Setting	Internal sync	SYNC Reset
5	Shutter-speed Switch Setting	HD / VD IN (*1)	SYNC Non-reset
6	Shutter-speed TRIG Pulse-width Setting	HD / VD IN (*1)	SYNC Non-reset
7	Shutter-speed Switch Setting	HD / VD IN (*2)	SYNC Non-reset
8	Shutter-speed TRIG Pulse-width Setting	HD / VD IN (*2)	SYNC Non-reset

*1: Consecutive HD / Consecutive VD IN

*2: Consecutive HD / Single VD IN

(20) Special shutter

User-defined shutter-timing and shutter-speed cued and timed by shutter trigger and restart / reset pulse input ON / OFF selectable via rear panel DIP SW (Initial factory setting: OFF)

(21) CCD integration mode

Field / Frame storage(integration)

Switch-able by rear panel DIP Switch Selection (Initial factory setting : frame integration)

(22) Restart/Reset

Restart / Reset function available via rear panel DIP-SW selection (Initial factory setting: OFF)

(23) Power source

DC12V ± 10% [Ripple level : Less than 10mV(p-p)]

(24) Power consumption

approx. 1.3W

(25) Ambient condition

·Performance assurance

Temperature 0°C ~ 40°C

Humidity 20 ~ 80% (No condensing)

·Operation assurance

Temperature -10°C ~ 50°C

Humidity 20 ~ 80% (No condensing)

·Storage

Temperature -20°C ~ 60°C

Humidity 20 ~ 95% (No condensing)

(26) Lens mount

C-mount

(27) Flange back

17.526mm

(28) Dimensions

29(W) × 29(H) × 31(D)mm (Excluding protruding part)

(29) Mass

Approx. 42g

(30) Option unit

·Power adapter

CA130D (AC100V)

• Power / Video connector (Maker : Hirose denki)

HR10A-10P-12S

• Camera cable

CPRC3700 (2m,3m, 5m, 10m)

• Tripod adapter

• IR cut filter

*** Conformity of EMC conditions**

About the conformity of the EMC standard of this machine, it has guaranteed in the conditions combined with the recommended parts.

When used combining parts other than specification of our company, I ask you to have final EMC conformity checked of a visitor with a machine and the whole equipment.

(31) Connector Pin Assignment

Compatible plug: HR10A-10P-12S (Manufactured by HIROSE ELEC.)

Pin No.	External sync.			Internal sync.
	HD VD	VS/SYNC	R.R.	
1	GND	GND	GND	GND
2	+12V	+12V	+12V	+12V
3	GND	GND	GND	GND
4	VIDEO OUT	VIDEO OUT	VIDEO OUT	VIDEO OUT
5	GND	GND	GND	GND
6	HD IN	----	HD IN	HD OUT*
7	VD IN	VS/SYNC IN	R.R. IN	VD OUT*
8	GND	GND	GND	GND
9	CLOCK OUT	CLOCK OUT	CLOCK OUT	CLOCK OUT
10	WEN OUT	WEN OUT	----	WEN OUT
11	TRIG IN	TRIG IN	TRIG IN	TRIG IN
12	GND	GND	GND	GND

* HD VD output is available via inner SW selection under internal sync operation.

5. Guarantee

The term of guarantee is one year after the product delivery.

If by any chance trouble by responsibility of our company occurs before an above period, TELI repairs it free of charge.

-During terms of a guarantee, when the trouble cause is the case of below, TELI charges the repair costs.

- (1) Troubles and the damages that causes by misuse, unsuitable repair or remodeling.
- (2) Distribution hazards like drops and vibrations after purchase. Troubles and damages by transportation.
- (3) Troubles and damages by fire, natural calamity (earthquake, storm and flood damage, thunderbolt), damages from salty breeze, gas harm, abnormal voltage.

6. Repair

(1) Condition for repair

Basically, has to return it to our company when the user requests us to repair product.

Beside that, customer should pay these expenses (travel expenses, camera disassembly technology costs) of both customer and end user. Also customer should pay in themselves costs for return camera to us.

(2) The period of repairing product

- Repair free of charge Refer to Clause 5.
- Charged repair Basically, repair period is 7 years after the last production end of products.

7. Appearance

Typical spectral response

[The lens characteristics and light source characteristics is not reflected in the table.]

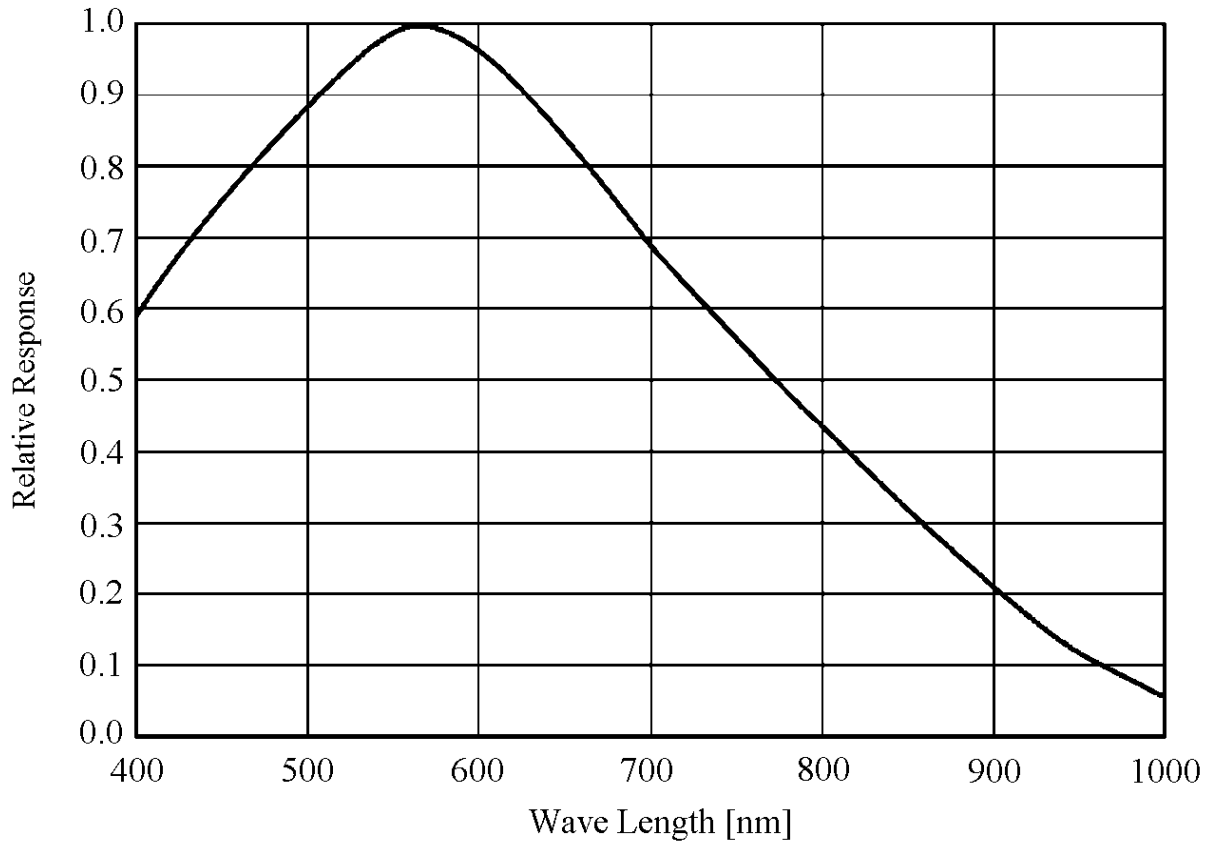

DRAWINGS

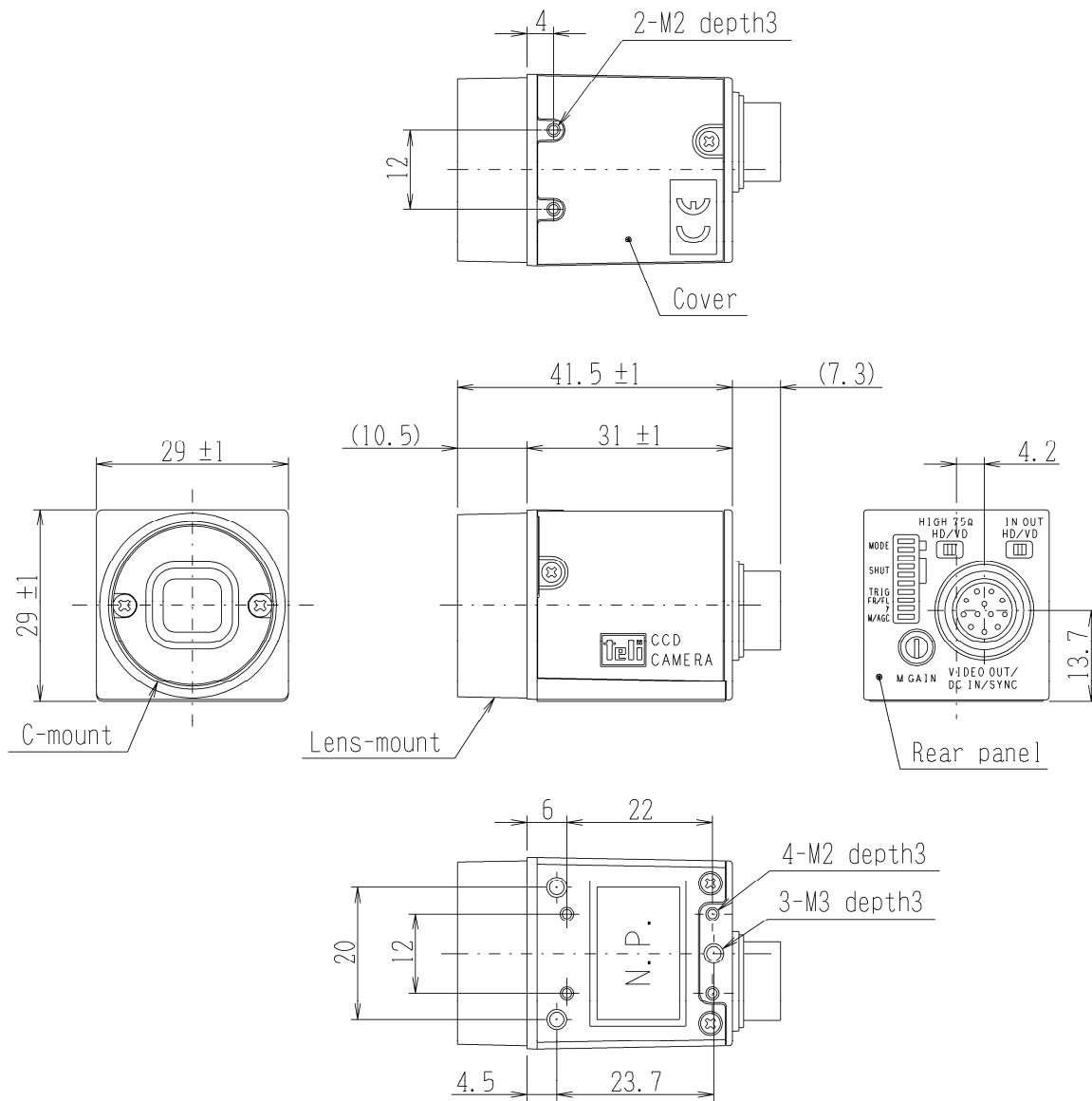

Specificatin

Material

Lens-mount, Rear panel : Aluminum die-cast
 Cover : Anticorrosion aluminum alloy

Processing

Lens-mount, Rear panel : Cation coating
 Cover : Leather satin coating (Black)



TOSHIBA TELI CORPORATION

Head Office : 7-1, 4 chome, Asahigaoka, Hino-shi, Tokyo, 191-0065, Japan
(International Business Department)

Phone : +81-42-589-8771

Fax : +81-42-589-8774

URL : <http://www.toshiba-teli.co.jp/>

Distributor

- This product must be classified for disposal according to the laws of each country and municipal laws.
 - Information contained in this document is subject to change without prior notice.
-