



High-Resolution CMOS Camera

Model CSB4000CL-10A

PRODUCT SPECIFICATION

Contents

Before use – General safety instructions

1. Product Description	1
2. Features	1
3. Configuration	1
4. Optional parts	1
5. Specifications	2
6. Connection	3
7. DIP Switch setting	4
8. Functions	5
9. Timing Chart	8
10. COMMAND table	9
11. External View	10

TOSHIBA TELI CORPORATION

BEFORE USE - GENERAL SAFETY INSTRUCTIONS



This instruction manual contains important information for the operator (user) and/or people in the vicinity to avoid personal injury, or property damage.

- Prior to use, read this operation manual carefully to fully understand its instructions for correct use.
- After reading, keep this manual near the equipment for future reference.

WARNINGS & CAUTIONS



[Definition of markings]

The meaning of each mark used in this instruction manual is given below.

 WARNING	This mark warns the user that improper use may cause death or severe personal injury of the user or people in the vicinity.
 CAUTION	This mark warns the user that improper use may cause personal injuries (*1) or material damages (*2) against the user or people in the vicinity.

Notes *1: Personal injury means wounds, burns, electric shocks, and others for which hospitalization or long term care are not required.

*2: Material damage means any direct or consequential damage related to property or material loss.

	This mark indicates what the user SHOULD NOT DO . The details are given adjacent the mark.
	This mark indicates what the user MUST DO . The details are given adjacent the mark.

WARNING



unplug

- **Immediately cease use of the equipment in the event of abnormality or malfunction.**
If abnormal conditions are present, such as smoke, a burning smell, ingress of water or foreign matter, or if the equipment is dropped or malfunctions, fire or electric shock may result. If such abnormalities occur, disconnect the power plug from the outlet and contact your sales representative.
-



Do not get wet

- **Do not use the equipment in locations subject to water splashes.**
Otherwise, fire or electric shock may result.
-



Never pull apart

- **Do not disassemble, repair, or modify the equipment.**
Otherwise, fire or electric shock may result. For internal repair, inspection, or cleaning, contact your sales representative.
-



Avoid

- **Do not place anything on the equipment.**
If metallic objects, liquid, or other foreign matter enters the equipment, fire or electric shock may result.
-



Avoid

- **Do not install the equipment in an unstable or inclined location or locations subject to vibration or impact.**
Otherwise, the equipment may topple over and cause personal injury.
-



Do not touch

- **During an electrical storm, do not touch the power cord or connection cable.**
Otherwise, an electric shock may result.
-



Instruction

- **Use the specified power supply.**
Use of an unspecified power supply may result in fire or electric shock.
-

CAUTION



Instruction

- **Observe the following when installing the equipment:**
 - Do not cover the equipment with a cloth, etc.
 - Do not place the equipment in a narrow location where heat is likely to accumulate. Otherwise, heat will accumulate inside the equipment, possibly resulting in a fire.



Avoid

- **Do not place the equipment in locations subject to high moisture, oil fumes, steam, or dust.** Otherwise, fire or electric shock may result.



Avoid

- **Do not install the equipment in locations exposed to direct sunlight or humidity.** Otherwise, the internal temperature of the equipment will rise, which may cause a fire.



Avoid

- **Use only specified DC power cables and connection cables.** Otherwise, fire or electric shock may result.



Avoid

- **When performing connection, turn off power.** When connecting the power cable or connection cable, turn off the equipment power. Otherwise, fire or electric shock may result.



Instruction

- **Contact your sales representative to request periodic inspection and cleaning (every approx. five years).** Accumulation of dust inside the equipment may result in fire or electric shock. For inspection and cleaning costs, contact your sales representative.
-

CASES FOR INDEMNITY (LIMITED WARRANTY)

We shall be exempted from taking responsibility and held harmless for damage or losses incurred by the user in the following cases.

- In the case damage or losses are caused by fire, earthquake, or other acts of God, acts by a third party, deliberate or accidental misuse by the user, or use under extreme operating conditions.
- In the case of indirect, additional, consequential damages (loss of business interests, suspension of business activities) are incurred as result of malfunction or non-function of the equipment, we shall be exempted from responsibility for such damages.
- In the case damage or losses are caused by failure to observe the information contained in the instructions in this instruction manual and specifications.
- In the case damage or losses are caused by use contrary to the instructions in this instruction manual and specifications.
- In the case damage or losses are caused by malfunction or other problems resulting from use of equipment or software that is not specified.
- In the case damage or losses are caused by repair or modification conducted by the customer or any unauthorized third party (such as an unauthorized service representative).
- Expenses we bear on this product shall be limited to the individual price of the product.

RESTRICTION FOR USE

- Should the equipment be used in the following conditions or environments, give consideration to safety measures and inform us of such usage:
 1. Use of the equipment in the conditions or environment contrary to those specified, or use outdoors.
 2. Use of the equipment in applications expected to cause potential hazard to people or property, which require special safety measures to be adopted.
- This product can be used under diverse operating conditions. Determination of applicability of equipment or devices concerned shall be determined after analysis or testing as necessary by the designer of such equipment or devices, or personnel related to the specifications. Such designer or personnel shall assure the performance and safety of the equipment or devices.
- This product is not designed or manufactured to be used for control of equipment directly concerned with human life (*1) or equipment relating to maintenance of public services/functions involving factors of safety (*2). Therefore, the product shall not be used for such applications.

(*1): Equipment directly concerned with human life refers to:

 - Medical equipment such as life-support systems, equipment for operating theaters.
 - Exhaust control equipment for exhaust gases such as toxic fumes or smoke.
 - Equipment mandatory to be installed by various laws and regulations such as the Fire Act or Building Standard Law
 - Equipment related to the above

(*2) Equipment relating to maintenance of public services/functions involving factors of safety refers to:

 - Traffic control systems for air transportation, railways, roads, or marine transportation
 - Equipment for nuclear power generation
 - Equipment related to the above

Usage Precautions

- **Handle carefully**
Do not drop the equipment or allow it to be subject to strong impact or vibration, as such action may cause malfunctions. Further, do not damage the connection cable, since this may cause wire breakage.

 - **Environmental operating conditions**
Do not use the product in locations where the ambient temperature or humidity exceeds the specifications. Otherwise, image quality may be degraded or internal components may be adversely affected. In particular, do not use the product in areas exposed to direct sunlight. Moreover, during shooting under high temperatures, vertical stripes or white spots (noise) may be produced, depending on the subject or camera conditions (such as increased gain). However, such phenomena are not malfunctions.

 - **Do not shoot under intense light.**
Avoid intense light such as spot lights on part of the screen because it may cause blooming or smears. If intense light falls on the screen, vertical stripes may appear on the screen, but this is not a malfunction.

 - **Occurrence of moiré**
If you shoot thin stripe patterns, moiré patterns (interference fringes) may appear. This is not a malfunction.

 - **Occurrence of noise on the screen**
If an intense magnetic or electromagnetic field is generated near the camera or connection cable, noise may be generated on the screen. If this occurs, move the camera or the cable.

 - **Handling of the protective cap**
If the camera is not in use, attach the lens cap to the camera to protect the image pickup surface.

 - **If the equipment is not to be used for a long duration**
Turn off power to the camera for safety.

 - **Maintenance**
Turn off power to the equipment and wipe it with a dry cloth.
If it becomes severely contaminated, gently wipe the affected areas with a soft cloth dampened with diluted neutral detergent. Never use alcohol, benzene, thinner, or other chemicals because such chemicals may damage or discolor the paint and indications.
If the image pickup surface becomes dusty, contaminated, or scratched, consult your sales representative.

 - **Disposal**
When disposing of the camera, it may be necessary to disassemble it into separate parts, in accordance with the laws and regulations of your country and/or municipality concerning environmental contamination.
-

CMOS sensor characteristics

- **Defective pixels**

A CMOS image sensor is composed of photo sensor pixels in a square grid array. Due to the characteristics of CMOS image sensors, over- or under-driving of the pixels results in temporary white or black areas (as if these are noises) appearing on the screen. This phenomenon, which is not a defect is exacerbated under higher temperatures and long exposure times.

- **Image shading**

Under global shutter operation, the brightness of the upper part of the screen may differ from the lower part. However, this does not mean the CMOS image sensor is defective.

This phenomenon occurs under short exposure times and high illumination.

To counteract this phenomenon, reduce the illumination by setting a longer exposure time, or adjust the lens aperture.

It may be blurred by this phenomenon when fast-moving subject captured.

1. Product Description

Model CSB4000CL-10A is a high-resolution B/W CMOS camera achieving high-speed image processing by a random access.

2. Features

(1) Ultra-high resolution

The CSB4000CL-10A features a high-pixel CMOS sensor (Total pixel count: 4.19 Mega pixels), enabling high-density images (i.e., significantly reduced moiré and beat) to be obtained.

(2) Global shutter mode

This model features a Global shutter mode, which means that clear images of a fast-moving subject with little blurring are obtained.

(3) Random trigger shutter mode

This feature starts light-exposure in synchronization with an external trigger signal, and enables image capture at any given timing.

(4) WOI (Window Of Interest)

WOI is a feature enabling high-speed image processing.

By designating horizontal and vertical addresses, user-defined areas only are read out.

(5) High-dynamic range

This model features a high-dynamic range with multi slope integration mode, both high- and low-intensity subjects can be captured at the same time despite the high difference in contrast.

(6) SUBSAMPLING

Readout of active pixels is lowered, enabling increased frame rates.

This mode suitable for image orientation and confirmation.

3. Configuration

- (1) Camera body 1
- (2) Operation Manual..... 1

4. Optional parts

- (1) Power cable (Model name: CPRC3700-**: 1m-9m)
- (2) Camera Link cable (Model name: 14B26-SZLB-***-0LC :2m-10m)
- (3) Camera mounting kit (CPT4000CL)
- (4) TFL lens mount adapter (Model name: TCAR)
- (5) Camera adapter (Model name: CA150, CA130C-01)

*NOTE: Application software is not supplied as a standard item.

*Conformity of optional peripherals and EMC regulations

The above-mentioned parts are guaranteed to conform to EMC standards.

If non-specified parts are to be used in combination, we suggest an inspection from one of our testing team to verify conformity with EMC standards.

5. Specification

Model	CSB4000CL-10A	
Image sensor	CMOS Image sensor	
Total pixel	2048 (H) x 2048 (V)	
Active pixel	2008 (H) x 2047 (V)	
Pixel size	6.0 (H) x 6.0 (V) micro m	
Image area	12.048 x 12.282 mm	
Driving frequency	33.3333MHz	
Scanning line	2047 lines	
Scanning system	Progressive	
Flame rate	7.29 fps (Under Rolling shutter mode and all pixel's data read out mode)	
Sync system	Internal	
Aspect ratio	1:1	
Subject illumination	2000 lx, F4 (3100K)	(Exposure time: Approx. 16 ms)
Video output	Camera link (LVDS, 10bit,	Pixel clock 33.3333MHz)
S/N	47 dB (p-p) / rms	(Exposure time: Approx. 16 ms)
Control signal	Refer to COMMAND table	
Gamma	1.0 Fixed	
Electronic shutter	Shutter speed setting by any given timing through Camera Link communication command.	
Shutter mode	Global shutter / Rolling shutter	
Random Trigger Shutter	RTS operation is available by external trigger signal IN. Shutter speed preset or shutter speed control by pulse width is available. The exposure starts at shutter trigger rising edge and ends at shutter trigger falling edge under pulse width control for shutter speed.	
Power source	DC12V +/- 10% (Source ripple level 100mV(p-p) or less)	
Power consumption	Approx. 1.1W	
Ambient condition	Temperature: (Performance guaranteed) From 0 through 40 degrees Celsius (Operation guaranteed) From -10 through 50 degrees Celsius (Preservation) From -20 through 60 degrees Celsius Humidity: (Performance guaranteed) From 20 through 80 % (No condensing) (Operation guaranteed) From 20 through 80 % (No condensing) (Preservation) From 20 through 95 % or less (No condensing)	
Lens mount	C-mount TFL mount is also available by replacement of lens mount adapter. <u>In the use of the standard C-mount lens, a resolution and brightness on the periphery in the screen might be deteriorated, leading not to make full use of the capability of the camera's original performances. The use of TFL-mount lens or lens for line sensor is recommended for making full use of the capabilities of the performance.</u> <u>Please contact our sales person for your further detail.</u>	
Flange back	17.526 mm	
External dimension	54 (W) x 43 (H) x 59 (D) mm	(Without projection)
Weight	Approx. 160 g	
Electro-Magnetic Compatibility	(1) EMI(Electro-Magnetic Interference) EN50081-2(EN55011-A) adaptation (2) EMS(Electro-Magnetic Susceptibility) EN61000-6-2 adaptation	

* Please contact our sales person about interface specification.

6. Connection

(1) DC IN

Connector (Camera side): HR10A-10R-12PB (Manufactured by HIROSE DENKI)
 Plug (Cable side): HR10A-10P-12S (Manufactured by HIROSE DENKI)

Pin number	Signal name
1	GND
2	+12V
3	GND
4	N.C.
5	GND
6	N.C.
7	N.C.
8	GND
9	N.C.
10	N.C.
11	N.C.
12	GND

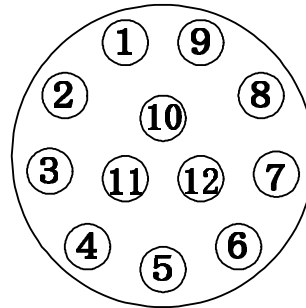

Rearview

(2) DATA IN/OUT

Connector (Camera side): 10226-2210VE (Manufactured by 3M)
 Connector (Cable side): 10126-6000 (Manufactured by 3M)

PIN.	Signal Name	I/O	PIN.	Signal Name	I/O
1	GND		14	GND	
2	TX OUT 0-	OUT	15	TX OUT 0+	OUT
3	TX OUT 1-	OUT	16	TX OUT 1+	OUT
4	TX OUT 2-	OUT	17	TX OUT 2+	OUT
5	TX CLK OUT-	OUT	18	TX CLK OUT+	OUT
6	TX OUT 3-	OUT	19	TX OUT 3+	OUT
7	Ser TC(RxD)+	IN	20	Ser TC(RxD)-	IN
8	Ser TFG(TxD)-	OUT	21	Ser TFG(TxD)+	OUT
9	Trig-	IN	22	Trig+	IN
10	EXT AFR+	IN	23	EXT AFR-	IN
11	EXT SP-	IN	24	EXT SP+	IN
12	EXT VR +	IN	25	EXT VR -	IN
13	GND		26	GND	

7. DIP switch setting

The setting of each mode can be done with DIP switches located on the rear panel.

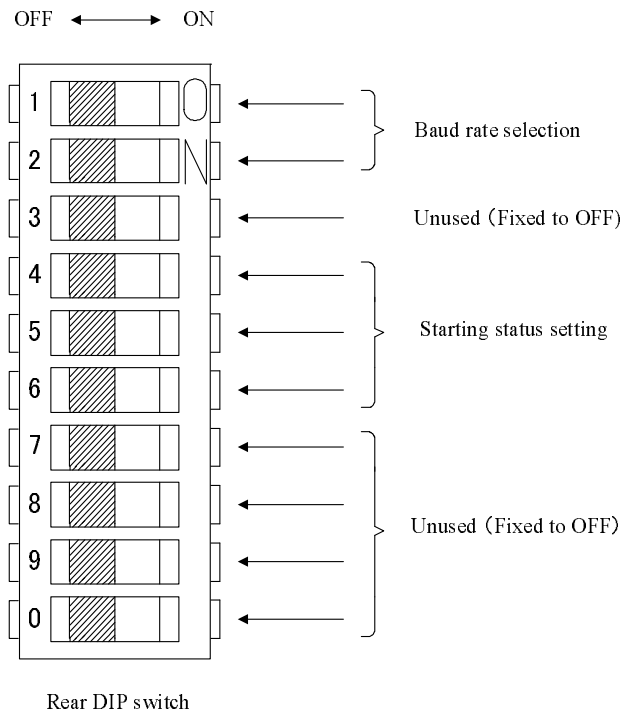

(1) Baud rate setting: Baud rate setting of camera IN /OUT

[1]	[2]	Baud rate
OFF	OFF	9600
ON	OFF	19200
OFF	ON	38400

(2) Starting status setting: Designate the memory page readout in starting up of a camera

[4]	[5]	[6]	Memory
OFF	OFF	OFF	0
ON	OFF	OFF	1
OFF	ON	OFF	2
ON	ON	OFF	3
OFF	OFF	ON	4
ON	OFF	ON	5
OFF	ON	ON	6
ON	ON	ON	7

8. Function

(1) Electronic shutter

The shutter-speed of CSB4000CL-10A is also manually adjustable. By manipulating the internal register setting value of CSB4000CL-10A, you can change the shutter-speed by user-defined setting value of 65.8 micro sec step.

* The longer a user sets the exposure time, the more defective pixels on the image is outstanding. When you attach importance to image quality, it is recommendable to set the shutter speed at 30 msec or less.

(2) Random trigger shutter

Under the RTS mode, the camera can capture image at any user-defined timing with external trigger signal.

Under FIX mode, shutter speed can be set with the internal resister setting value.

Under pulse mode, shutter speed can be set with the trigger pulse width.

You can change the polarity of trigger pulse with the internal resister setting value.

* Random trigger shutter function is available only under global shutter mode.

(3)Sub-sampling

Horizontal and vertical thinning-out reading is performed at every 1 line.

3 types of settings are available (1/2 horizontal only, 1/2 vertical only and 1/2 both).

This function can read out the full image at high speed while its resolution is deteriorated.

* The combined use with WOI cannot be performed.

(4) Multi slope function

By changing a slope position with internal resister setting value, you can set the sensitivity matching to the subject luminance.

Refer to the interface specifications for the details of the setting method separately.

(5)WOI (Window of interest)

Only user-defined area can be captured by designating of the horizontal and the vertical address.

Up to 16 areas can be set in 1 screen.

This function can increase a frame rate because the area other than designated is not captured.

The minimum area size is 40 dot(H) x 1 dot(V).

Horizontal address can set up only even number.

The placement is available up to 16 windows in all active pixel area.

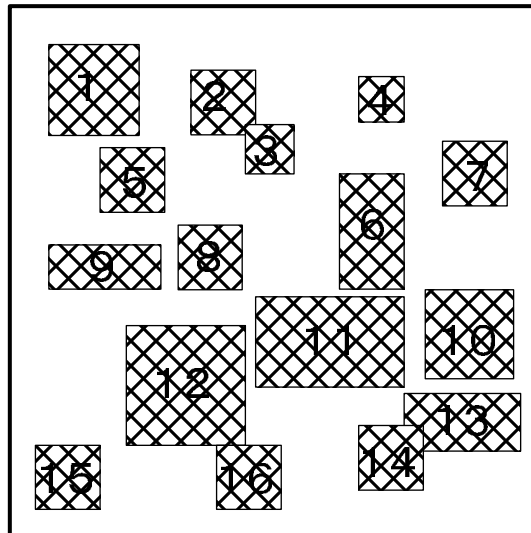

The setting of readout address is available up to 8 types.

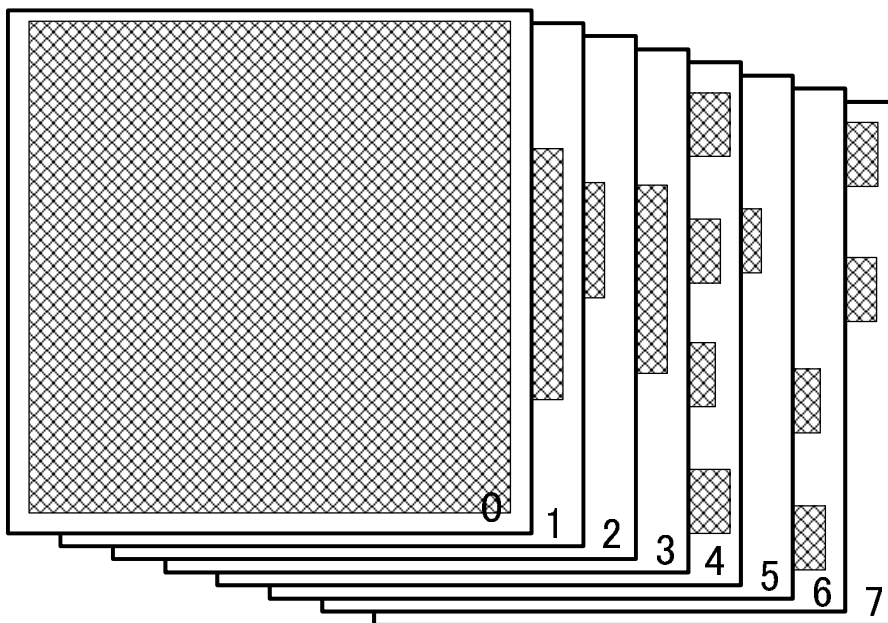

User can reprogram all setting types from 0 through 7.

Practical operation example

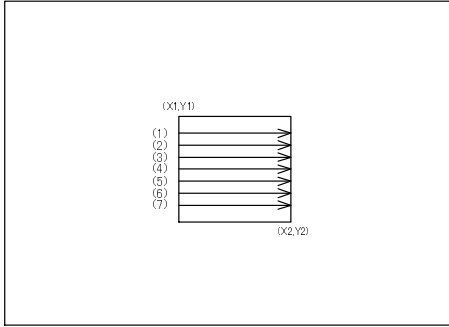

In the case of only one readout area

A readout area can be designated by the start address (X1, Y1) and the end address (X2, Y2). The camera can read out the user-defined area through this function.

The each address is designated by the start address and lengths (pixel numbers) of “X” and “Y” directions.

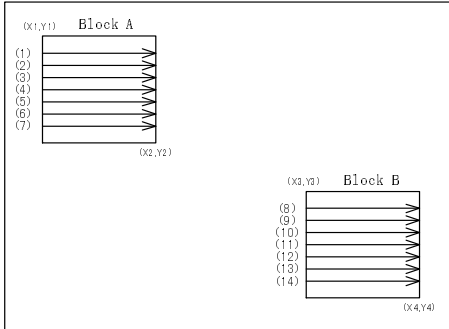

In the case of more than two readout areas

The area designated by the start address (X1, Y1) and the end address (X2, Y2) is read out first (block A in the left figure).

After reading out of block A, the next area designated by (X3, Y3) and (X4, Y4) is read out (block B in the left figure).

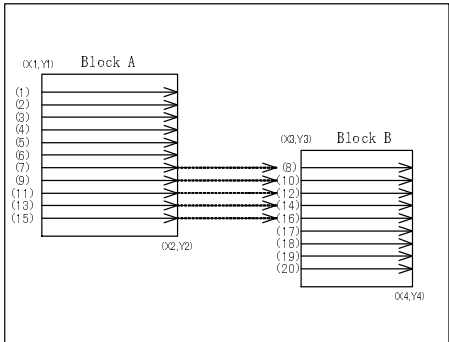

In the case of more than two readout areas which both comprise the same readout lines

The designated areas are read out in order of address from the start (X1, Y1) to the end (X4, Y4).

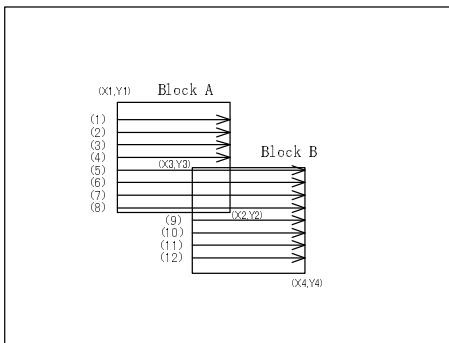

In the case of more than two readout areas overlapping each other

The designated areas are read out in order of address from the start (X1, Y1) to the end (X4, Y4).

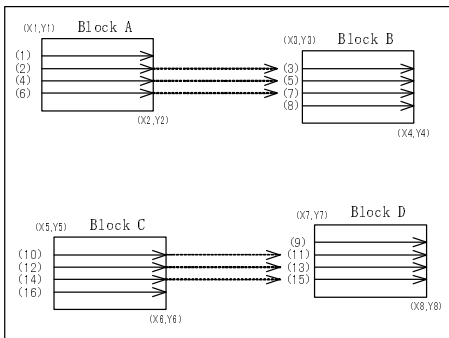

In the case of four readout areas

The designated areas are read out in order of address from start (X1, Y1) to the end (X8, Y8).

9. Timing Chart

(1) Normal shutter mode (in all pixel data readout)

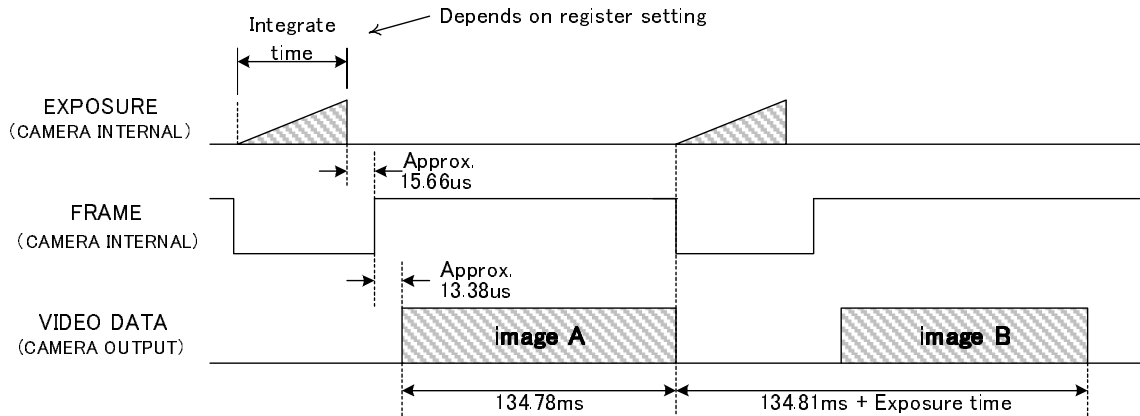

(2) Random Trigger Shutter mode (Fix mode)

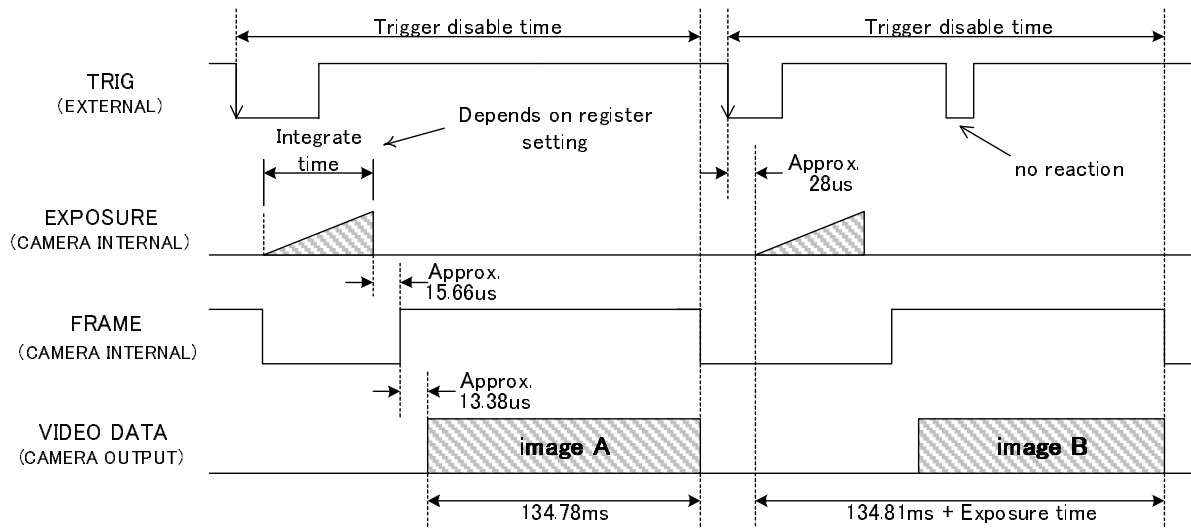

Shutter speed depends on the internal register setting value.
 After trigger IN, next trigger signal is not acceptable until the readout is completed.

(3) Random trigger shutter (pulse mode)

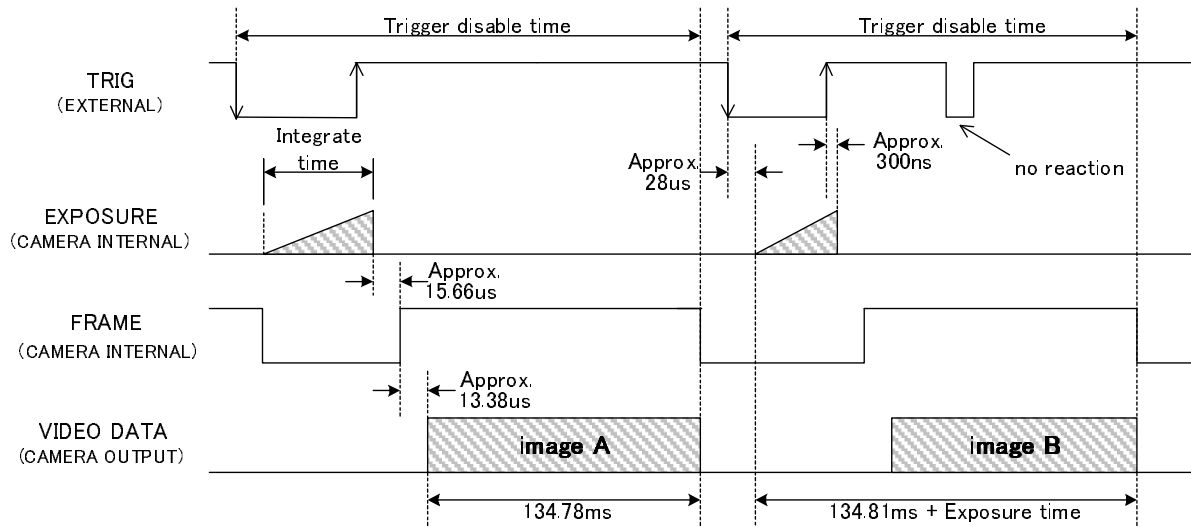

Shutter speed depends on the trigger pulse width.
 After trigger IN, next trigger signal is acceptable until the readout is completed.

(4) WOI (Window of interest)

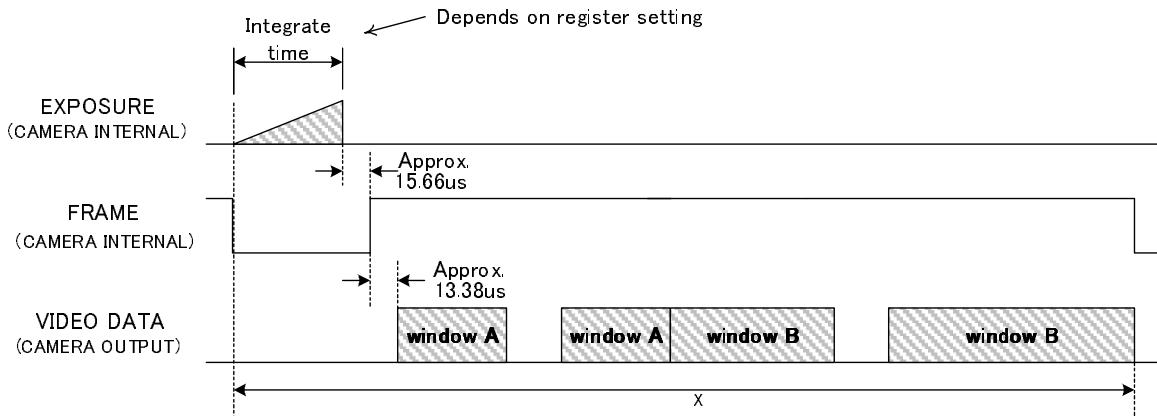

10. COMMAND Table

Video level	Setup
Shutter	Shutter mode
	Shutter speed
Trigger	Polarity
	Enable/Disable
Multi slope	Knee point number
	Shutter speed of each slope
Window	Enable/Disable
	Starting coordinate
	Ending coordinate
Memory	Setting value readout
	Setting value storage
	Rreset
Other	Video OUT bit width
	Sub Sampling
	Vendor name
	Model name

11. External View

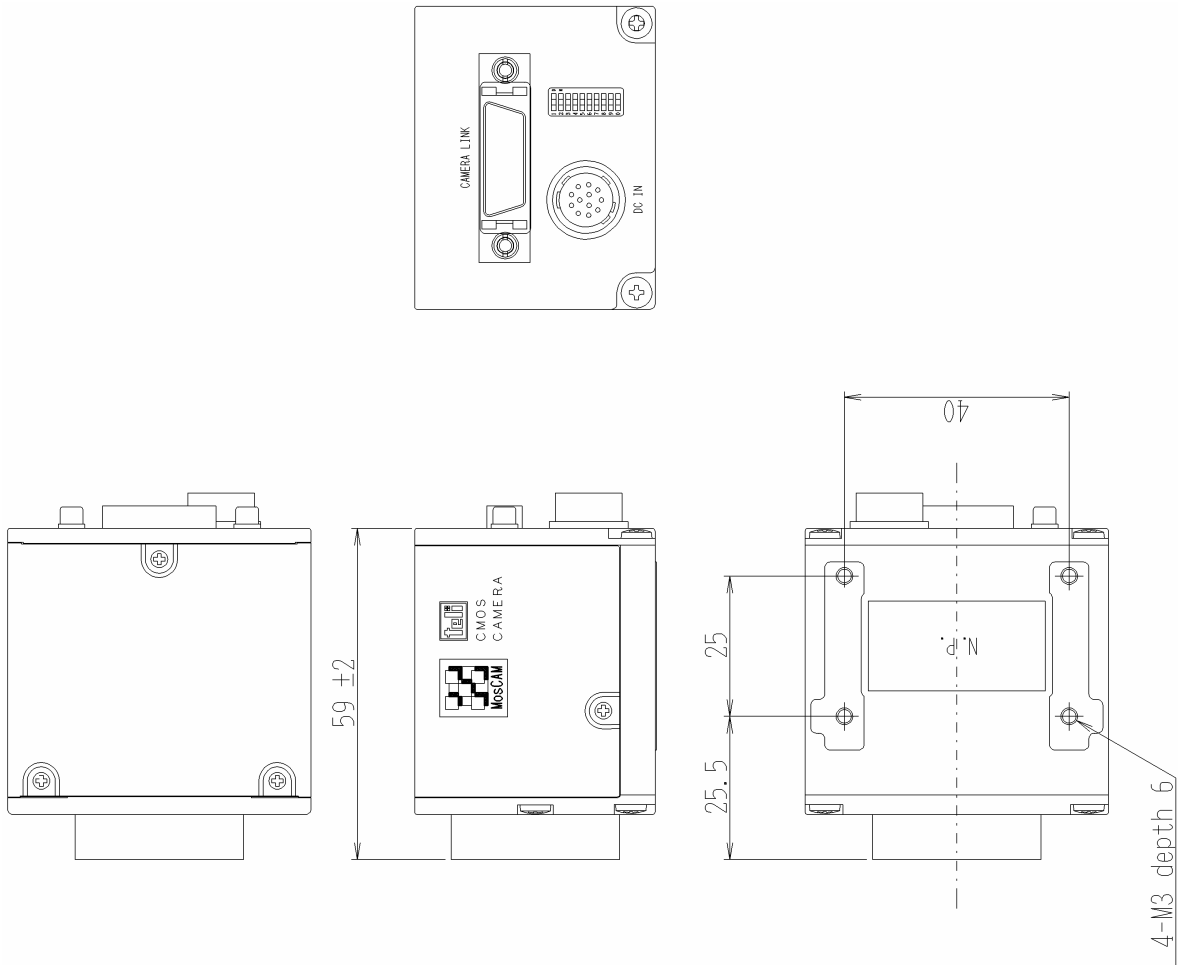

- Design specifications
- Material
 - Mount, Chassis, Rear panel : Die-cast Aluminum
 - Cover : Anticorrosion aluminum alloy
 - Processing
 - Mount, Chassis, Rear panel : Cation coating
 - Cover : Leather satin coating
 - Coating color : Black